

# REPAIR MANUAL



135

137

153

**1300 ProTough**

Publication No. 49702

September , 2004

# THOMAS

## THOMAS EQUIPMENT LIABILITY WARRANTY

**THE WARRANTY IS THE ONLY OBLIGATION OF THOMAS OR A THOMAS DEALER TO THE PURCHASER OR ANYONE ELSE CONCERNING A PRODUCT, ITS SERVICE, ITS USE OR PERFORMANCE OR ITS LOSS OF USE OR FAILURE TO PERFORM. NEITHER THOMAS NOR A THOMAS DEALER HAVE MADE AND NEITHER WILL MAKE ANY OTHER EXPRESSED OR IMPLIED REPRESENTATION, WARRANTY OR AGREEMENT CONCERNING A PRODUCT. NEITHER THOMAS NOR A THOMAS DEALER HAVE MADE OR WILL MAKE ANY REPRESENTATION, WARRANTY OR AGREEMENT CONCERNING A PRODUCTS MERCHANTABILITY OR OTHER QUALITY, ITS SUITABILITY FOR PURCHASER'S PURPOSE (EVEN IF A PURCHASER HAS INFORMED THOMAS OR A THOMAS DEALER OF THAT PURPOSE), ITS DURABILITY, PERFORMANCE OR OTHER CONDITION.**

**EVEN IF THOMAS OR A THOMAS DEALER WAS ADVISED OF THE POSSIBILITY OF SUCH LOSS, NEITHER THOMAS NOR A THOMAS DEALER WILL BE LIABLE TO PURCHASER OR ANYONE ELSE FOR ANY INDIRECT, INCIDENTAL CONSEQUENTIAL, PUNITIVE, ECONOMIC, COMMERCIAL, OR SPECIAL LOSS WHICH IS IN ANY WAY ASSOCIATED WITH A PRODUCT. THIS INCLUDES ANY LOSS OF USE OR NON-PERFORMANCE OF A PRODUCT, ANY REPLACEMENT RENTAL OR ACQUISITION COST, ANY LOSS OF REVENUE OR PROFITS, ANY FAILURE TO REALIZE EXPECTED SAVINGS, ANY INTEREST COSTS, ANY IMPAIRMENT OF OTHER GOODS, ANY INCONVENIENCE OR ANY LIABILITY OF PURCHASER TO ANY OTHER PERSON.**

**PURCHASER MAY NOT ATTEMPT TO ENLARGE ITS RIGHTS UNDER THE WARRANTY BY MAKING A CLAIM FOR INDEMNITY, FOR BREACH OF CONTRACT, FOR BREACH OF COLLATERAL WARRANTY, FOR A TORT (INCLUDING NEGLIGENCE, MISREPRESENTATION OR STRICT LIABILITY) OR BY CLAIMING ANY OTHER CAUSE OF ACTION.**

**THE WARRANTY IS A CONDITION OF SALE OF THE PRODUCT TO PURCHASER AND WILL THEREFORE APPLY EVEN IF PURCHASER ALLEGES THAT THERE IS A TOTAL FAILURE OF THE PRODUCT.**

*N.B. Read and practice your **Thomas** operating and servicing instructions. Failure to do this may void your warranty.*

# FOREWORD

It is important when ordering replacement parts or making a service inquiry to provide both the model number and serial number of your Thomas loader. The serial number plate is located at the rear of the machine on the left hand side hydraulic oil tank. In the event that the serial number plate is missing, the serial number is stamped into the main frame inside the rear door.

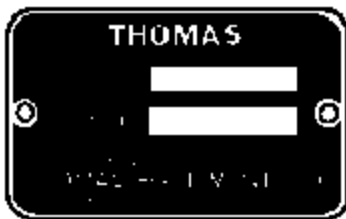
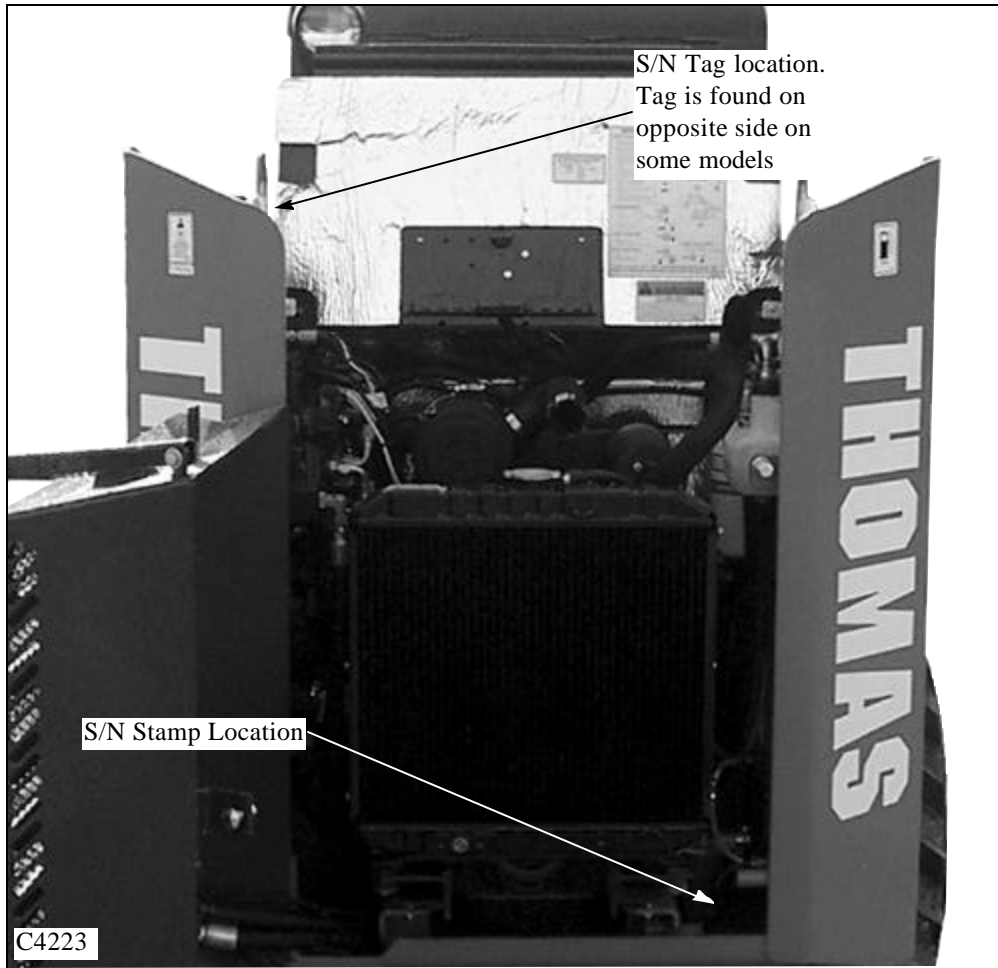

---

# SAFETY PRECAUTIONS

---

Practically all Service work involves the need to drive the loader. The Owner's / Operator's Manual, supplied with each loader, contains safety precautions relating to driving, operating and servicing that loader. These precautions are as applicable to the service technician as they are to the operator and should be read, understood and practiced by all personnel.

Prior to undertaking any maintenance or repair operations, make the necessary safety precautions to prevent possible personal injury to yourself, or to bystanders.

## PERSONAL CONSIDERATIONS

- \* **CLOTHING**  
The wrong clothing or carelessness in dress can cause accidents. Check to see that you are suitably clothed. Some jobs require special protective equipment.
- \* **SKIN PROTECTION**  
Avoid long term contact with used motor oil. Follow work practices that minimize the amount of skin exposed and length of time used oil stays on your skin.
- \* **EYE PROTECTION**  
Injury can be avoided by wearing eye protection when engaged in chiseling, grinding, welding, painting and any other task that involves airborne matter.
- \* **BREATHING PROTECTION**  
Fumes, dust and paint spray are unpleasant and harmful. These can be avoided by wearing respiratory protection.
- \* **HEARING PROTECTION**  
Loud noise may damage your hearing and the longer the exposure the greater the risk of hearing damage. Always wear hearing protection when working around loud machinery.
- \* **HAND PROTECTION**  
It is advisable to use a protective cream before work to prevent irritation and skin contamination. After work, clean your hands with soap and water. Solvents such as white spirits, paraffin, etc. may harm the skin.
- \* **FOOT PROTECTION**  
Substantial or protective footwear with reinforced toecaps will protect the feet from

falling objects.

- \* **SPECIAL CLOTHING**  
For certain work it may be necessary to wear flame or acid resistant clothing.

## EQUIPMENT CONSIDERATIONS

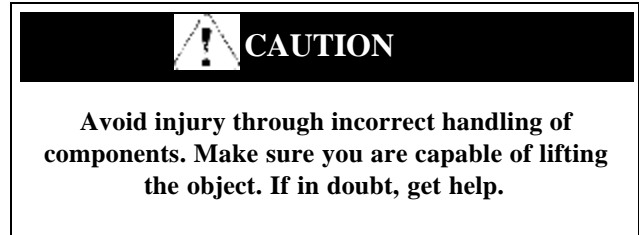

- \* **MACHINE GUARDS**  
Before using any machine, check to ensure that the machine guards are in position and serviceable. These guards not only prevent parts of the body or clothing coming in contact with the moving parts of the machine but also ward off objects that might fly off the machine and cause injury.
- \* **LIFTING APPLIANCES**  
Always ensure that lifting equipment, such as chains, slings, lifting brackets, hooks and eyes are thoroughly checked before use. If in doubt, select stronger equipment. Never stand under a suspended load or raised implement.
- \* **COMPRESSED AIR**  
The pressure from a compressed air line is often as high as 100 psi (6.9 bar). Any misuse may cause injury.  
  
Never use compressed air to blow dust, filing dirt, etc. away from your work area unless the correct type of nozzle is fitted.  
  
Compressed air is not a cleaning agent. It will only move dust etc. from one place to another. Look around before using an air hose as bystanders may get grit into their eyes, ears and skin.

---

# SAFETY PRECAUTIONS

---

\* **HAND TOOLS**

Many cuts, abrasions and injuries are caused by defective tools. Never use the wrong tool for the job as this leads either to injury or to a poor job.

Never Use:

- A hammer with a loose or split handle.
- Spanners or wrenches with spread or worn jaws.
- Wrenches or files as hammers, drills, clevis pins or bolts as punches.

For removing or replacing hardened pins use a copper or brass drift.

For dismantling, overhaul and assembly of major and sub-components always use the Special Service Tools recommended. These will reduce the work effort, labor time and the repair cost.

Always keep tools clean and in good working order.

\* **ELECTRICITY**

Electricity has become so familiar in day to day usage that it's potentially dangerous properties are often overlooked. Misuse of electrical equipment can endanger life.

Before using any electrical equipment, particularly portable appliances, make a visual check to ensure that the cable is not worn or frayed and that the plugs, sockets etc. are intact. Make sure you know where the nearest isolating switch for your equipment is located.

\* **HOUSEKEEPING**

Many injuries result from tripping or slipping over, or on, objects or materials left lying around by a careless worker.

Prevent these accidents from occurring. If you notice a hazard, don't ignore it, remove it.

A clean hazard free place of work improves the surroundings and daily environment for everybody.

\* **FIRE**

- Extinguish matches, cigars, cigarettes etc. before throwing them away.
- Work cleanly, disposing of waste material into proper containers.
- Locate all the fire extinguishers and ensure all personnel know how to operate them.
- Do not panic, warn those near and sound the alarm.
- Do not allow or use an open flame near the loader fuel tank, battery or component parts.

\* **CLEANLINESS**

Cleanliness of the loader hydraulic system is essential for optimum performance. When carrying out service and repairs, plug all hose ends and components connections to prevent dirt entry.

Clean the exterior of all components before carrying out any form of repair. Dirt and abrasive dust can reduce the efficiency and working life of a component and lead to costly replacement. Use of a high pressure washer or steam cleaner is recommended.

## GENERAL CONSIDERATIONS

\* **SOLVENTS**

Use only cleaning fluids and solvents that are known to be safe. Certain types of fluids can cause damage to components such as seals, etc. and can cause skin irritation. Solvents should be checked that they are suitable not only for the cleaning of components and individual parts but also that they do not affect the personal safety of the user.

---

# SAFETY PRECAUTIONS

---

## OPERATIONAL CONSIDERATIONS

- \* Stop the engine, if at all possible, before performing any service.
- \* Place a warning sign on loaders which, due to service or overhaul, would be dangerous to start. Disconnect the battery leads if leaving such a unit unattended.
- \* Do not attempt to start the engine while standing beside the loader or attempt to bypass the safety starting system.
- \* Avoid prolonged running of the engine in a closed building or in an area with inadequate ventilation as exhaust fumes are highly toxic.
- \* Always turn the radiator cap to the first stop to allow pressure in the system to dissipate when the coolant is hot.
- \* Never work beneath a loader which is on soft ground. Always take the unit to an area which has a hard working surface, preferably concrete.
- \* If it is found necessary to raise the loader for ease of maintenance, make sure that safe and stable supports are installed beneath the main frame before commencing work.
- \* Use footsteps or working platforms when servicing those areas of the loader that are not within easy reach.
- \* Before loosening any hoses or tubes, switch off the engine, remove all pressure in the lines by operating the foot pedals several times. This will remove the danger of personal injury by oil pressure.
- \* Prior to pressure testing, make sure all the hoses and connectors on both the loader and on the test machine are in good condition and tightly sealed. Pressure readings must be taken with the gauges specified. The correct procedure should be rigidly observed to prevent damage to the system or the equipment and to eliminate the possibility of personal injury.
- \* To avoid personal injury, service the loader with the arms down and the bucket or attachment on the ground. If it is necessary to service the loader with the boom arms raised, be sure to engage the boom supports. Never work under or around a loader with raised boom arms without boom support engaged.
- \* If high lift attachments are installed on a loader, beware of overhead power and telephone lines when travelling. Drop attachment near to ground level to increase stability and minimize risks.
- \* Do not park or attempt to service a loader on an incline. If unavoidable, take extra care and block the wheels.
- \* Escaping hydraulic / diesel fluid under pressure can penetrate the skin causing serious injury. Do not use your hand to check for leaks. Use a piece of cardboard or paper to search for leaks. Stop the engine and relieve pressure before connecting or disconnecting lines. Tighten all connections before starting the engine or pressurizing the lines. If any fluid is injected into the skin, obtain medical attention immediately.
- \* Prior to removing wheels and tires from a loader, check to determine whether additional ballast (liquid or weight) has been added. Seek assistance and use suitable equipment to support the weight of the wheel assembly.
- \* When inflating tires beware of over inflation; constantly check the pressure. Over inflation can cause tires to burst and result in personal injury.

---

# SAFETY PRECAUTIONS

---

## SERVICE TECHNIQUES

### A. SERVICE SAFETY

Appropriate service methods and proper repair procedures are essential for the safe, reliable operation of all motor vehicles as well as the personal safety of the individual doing the work. This shop manual provides general directions for accomplishing service and repair work with tested effective techniques. Following them will help assure reliability. There are numerous variations in procedures, techniques, tools and parts for servicing vehicles as well as in the skill of the individual doing the work. This manual cannot possibly anticipate all such variations and provide advice or cautions as to each. Accordingly, anyone who departs from the instructions provided in this manual must first establish that he or she compromises neither his personal safety nor the vehicle integrity by his choice of methods, tools or parts.

### B. SERVICE TECHNIQUES

Clean the exterior of all components before carrying out any form of repair. Dirt and abrasive dust can reduce the efficient working life of a component and lead to costly replacement.

Use cleaning fluids which are known to be safe. Certain types of fluid can cause damage to O-rings and cause skin irritation. Solvents should be checked that they are suitable for the cleaning of components and also that they do not risk the personal safety of the user.

Time spent on the preparation and cleanliness of working surfaces will pay dividends in making the job easier and safer and will result in overhauled components being more reliable and efficient in operation.

Replace O-rings, seals or gaskets whenever they are disturbed. Never mix new and old seals and O-rings, regardless of condition. Always lubricate new seals and O-rings with hydraulic oil before installation.

When replacing component parts use the correct tool for the job.

### C. HOSES AND TUBES

Always replace hoses and tubes if the end connections are damaged. Be sure any hose installed is not kinked or twisted.

When installing a new hose, loosely connect each end and make sure the hose takes up the designed position before tightening the connection. Clamps should be tightened sufficiently to hold the hose without crushing and to prevent chafing.

The hoses are the arteries of the unit. Be sure they are in good condition when carrying out repairs or maintenance. Otherwise the machines output and productivity may be affected.

After hose replacement to a moving component, check that the hose does not foul by moving the component through the complete range of travel.

Hose connections which are damaged, dented, crushed or leaking, restrict oil flow and the productivity of the components being served. Connectors which show signs of movement from the original swaged position have failed and will ultimately separate completely.

A hose with a chafed outer cover will allow water entry. Concealed corrosion of the wire reinforcement will subsequently occur along the hose length with resultant hose failure.

Ballooning of the hose indicates an internal leakage due to structural failure. This condition rapidly deteriorates and total hose failure soon occurs.

Kinked, crushed, stretched or deformed hoses generally suffer internal structural damage which results in oil restriction, a reduction in the speed of operation and ultimate hose failure.

Free moving, unsupported hoses must never be allowed to touch each other or related working surfaces. This causes chafing which reduces hose life.

### D. PRESSURE TESTING

Prior to pressure testing, be sure all hoses are in good condition and all connections tight. Pressure readings must be taken with gauges of specified pressure readings.

The correct procedure should be rigidly observed to prevent damage to the system or the equipment and to eliminate the possibility of personal injury.

# SAFETY PRECAUTIONS

## E. BEARINGS

Bearings which are considered suitable for further service should be cleaned in a suitable solvent and immersed in clean lubricating oil until required.

Installation of a bearing can be classified into two (2) ways:

- press fit on rotating parts such as shafts and gears,
- push fit into static locations such as reduction gear houses.

Where possible, always install the bearing onto the rotating components first. Use the correct tools or a press to install a bearing or bushing. In the absence of the correct tools or press, heat the bearing and / or casing in hot oil to assist the installation of the bearing.

When bearings or bushings are removed, always carefully check that the bearing is free from discoloration and signs of overheating. Also check for mechanical damage such as excessive clearance, nicks and scuffing. If in doubt, replace the bearings or bushings.

Bearings should never be removed unless absolutely necessary. Always use the recommended puller to reduce the risk of bearing or related component failure.

These bearings and bushings are subjected, in normal operation, to high working loads and adverse conditions.

Be sure during normal routine servicing, maintenance or repair that bearings are given the right attention and are installed with care.

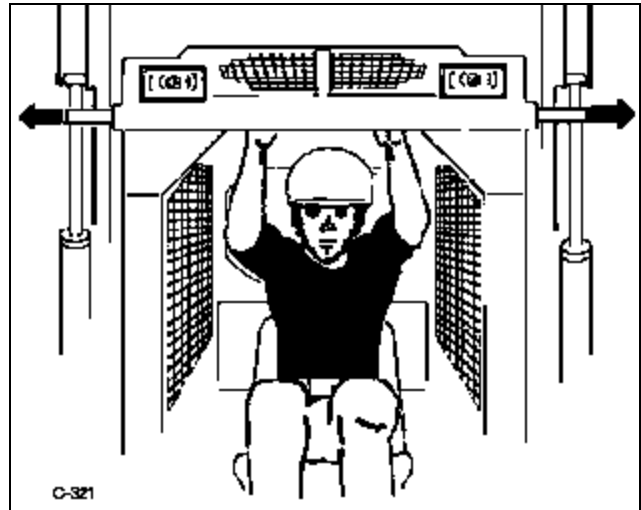
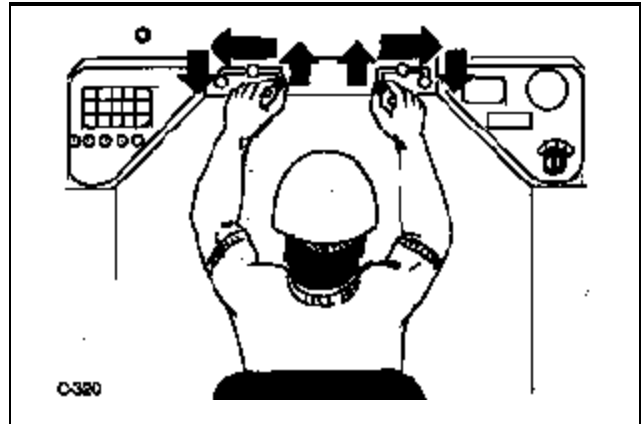

## F. BOOM SUPPORTS

For safety while performing regular service or maintenance work, the loader is equipped with boom supports.

The boom supports, when extended, prevent the boom arms from dropping if hydraulic pressure is relieved or the foot control pedals are accidentally cycled.

To operate the boom supports, first remove any bucket or attachment from the quick - tach; raise the boom arms to full height and shut off the engine. Raise the boom handles up and push out toward the boom arms to extend the boom supports.

**WARNING**

**To avoid personal injury, service the loader with the arms down and the bucket or attachment on the ground. If it is necessary to service the loader with the boom arms raised be sure to engage the boom supports. Never work under or around a loader with raised boom arms without boom supports engaged.**



---

# TABLE OF CONTENTS

---

<b>Section 1</b>	<b>Hydraulic System</b>
Hydraulic Circuit .....	1.1
Gear Pump .....	1.2
Control Valve .....	1.3
Hydraulic Cylinders .....	1.4
Oil Filter .....	1.5
Oil Cooler .....	1.6
Oil Reservoir .....	1.7
Trouble Shooting .....	1.8
Torque Chart .....	1.9
Conversion Chart .....	1.10
<b>Section 2</b>	<b>Hydrostatic Drive System</b>
Hydrostatic Circuit.....	2.1
Specifications.....	2.2
General Information.....	2.3
Trouble Shooting .....	2.4
Pressure Tests.....	2.5
Towing Procedure.....	2.6
Flushing The Hydraulic System .....	2.7
Start - up Procedure .....	2.8
Gear Pump Replacement .....	2.9
Tandem Pump Replacement .....	2.10
Tandem Pump Parts Diagram .....	2.11
Drive Motor .....	2.12
Torque Specifications .....	2.13
<b>Section 3</b>	<b>Final Drive</b>
Specifications and Maintenance .....	3.1
Lubrication.....	3.2
Drive Chain.....	3.3
Chain Tightener.....	3.4
Drive Motor Sprocket.....	3.5
Axle Assembly .....	3.6
Trouble Shooting .....	3.7
<b>Section 4</b>	<b>Controls</b>
Steering .....	4.1
Foot Pedals.....	4.2
Hand Controls.....	4.3
Throttle .....	4.4
Restraint Bar .....	4.5
Parking Brake .....	4.6
Trouble Shooting .....	4.7

---

# TABLE OF CONTENTS

---

<b>Section 5</b>	<b>Electrical</b>
Specifications .....	5.1
Wiring Schematics .....	5.2
Instrumentation .....	5.3
Ignition Switch .....	5.4
Engine Glow Plugs .....	5.5
Battery .....	5.6
Electrical Panel .....	5.7
Starter Circuit .....	5.8
Charging Circuit .....	5.9
Safety Circuit .....	5.10
Auxiliary Circuit .....	5.11
Accessory Circuit .....	5.12
Trouble Shooting .....	5.13
<b>Section 6</b>	<b>Main Frame</b>
Quick - Tach.....	6.1
Boom Arms .....	6.2
Boom Support .....	6.3
ROPS .....	6.4
Rear Door.....	6.5
<b>Section 7</b>	<b>Engine</b>
Maintenance.....	7.1
Cylinder Head.....	7.2
Replacement.....	7.3
Specifications.....	7.4
Trouble Shooting .....	7.5
<b>Section 8</b>	<b>Maintenance &amp; Specifications</b>
Maintenance.....	8.1
Trouble Shooting .....	8.2
Special Tools .....	8.3
Specifications.....	8.4
Decals .....	8.5

# SECTION 1 HYDRAULIC SYSTEM

<b>Hydraulic Circuit</b>	<b>1.1</b>
Layout .....	pg. 1-2
Schematic .....	pg. 1-3
Specifications .....	pg. 1-4
Maintenance Schedule .....	pg. 1-4
General Information .....	pg. 1-5
<b>Gear Pump</b>	<b>1.2</b>
Replacing the Gear Pump .....	pg. 1-6
Gear Pump Disassembly (137/153) .....	pg. 1-7 ~ 11
Gear Pump Reassembly (137/153) .....	pg. 1-12 ~ 14
Gear Pump Disassembly (1300/135) .....	pg. 1-15 ~ 17
Gear Pump Reassembly (1300/135) .....	pg. 1-18 ~ 20
<b>Control Valve</b>	<b>1.3</b>
Testing / Adjusting the Relief Valve .....	pg. 1-21 ~ 22
Control Valve Replacement .....	pg. 1-22 ~ 23
Exploded Illustration Diagram .....	pg. 1-24 ~ 25
Control Valve Disassembly / Repair(137/153) .....	pg. 1-26 ~ 31
Control Valve Disassembly/Repair(1300/135) .....	pg. 1-32 ~ 35
<b>Hydraulic Cylinders</b>	<b>1.4</b>
General Information .....	pg. 1-36
Testing Piston Seals .....	pg. 1-37
Lift Cylinder Replacement .....	pg. 1-38
Tilt Cylinder Replacement .....	pg. 1-39
Cylinder Disassembly .....	pg. 1-40 ~ 41
Cylinder Inspection .....	pg. 1-42
Cylinder Assembly .....	pg. 1-42 ~ 43
<b>Hydraulic Oil Filter</b>	<b>1.5</b>
General Information .....	pg. 1-44
Filter Replacement .....	pg. 1-44
<b>Hydraulic Oil Cooler</b>	<b>1.6</b>
General Information .....	pg. 1-45
Oil Cooler Replacement .....	pg. 1-45
<b>Hydraulic Oil Reservoir</b>	<b>1.7</b>
General Information .....	pg. 1-46
Checking the Oil Level .....	pg. 1-46
Adding Oil .....	pg. 1-46
Servicing the Reservoir .....	pg. 1-47
<b>Trouble Shooting</b>	<b>1.8</b>
Trouble Shooting Chart .....	pg. 1-48 ~ 49
<b>Torque Chart</b>	<b>1.9</b>
Torque Chart .....	pg. 1-49
<b>Conversion Charts</b>	<b>1.10</b>
Conversion Charts .....	pg. 1-50

# 1

## HYDRAULIC LAYOUT 1.1

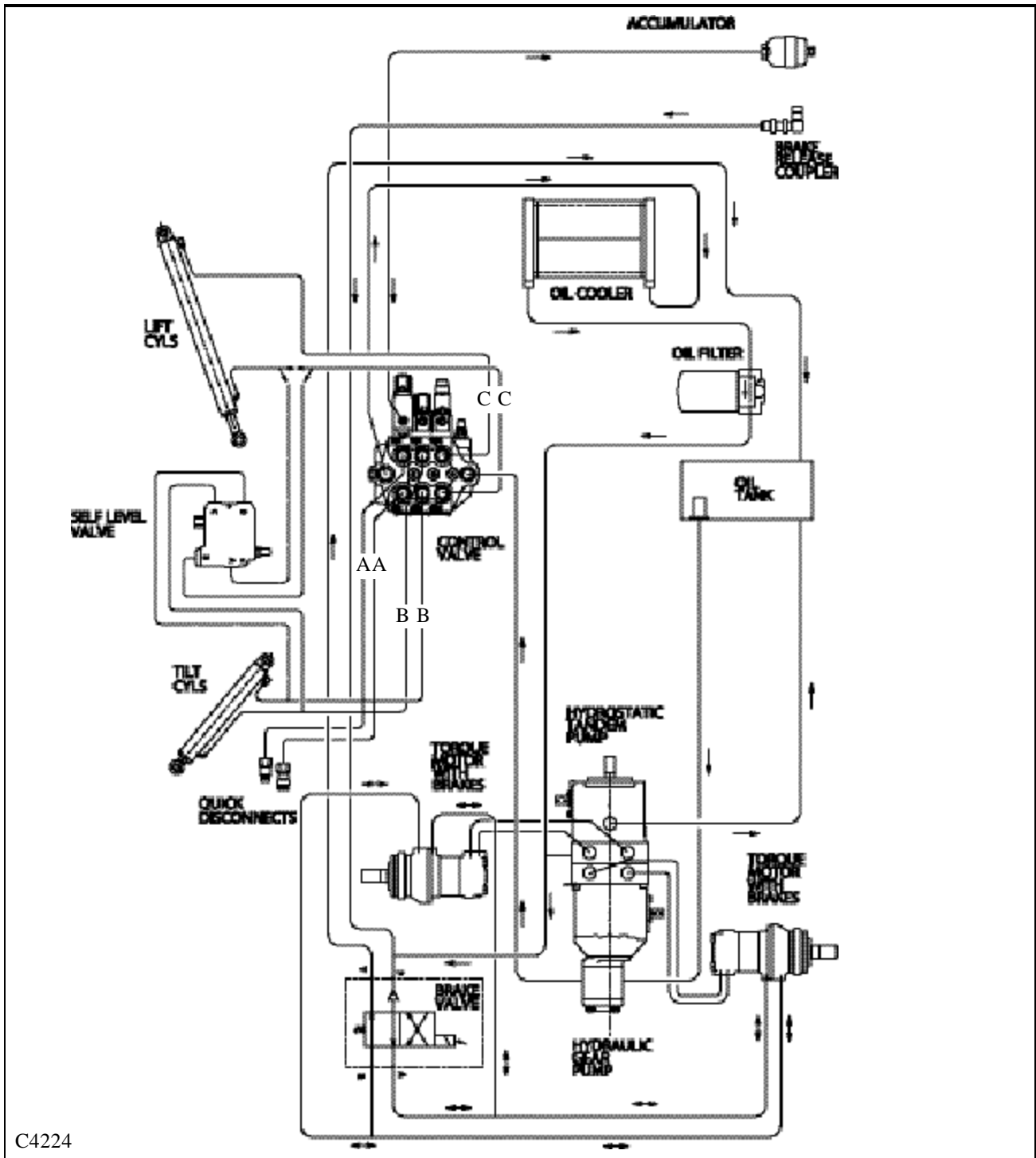

C4224

- A Auxiliary Circuit
- B Tilt Circuit
- C Lift Circuit

NOTE: Foot pedal control operated machine illustrated. Items (A3 / B3) are reversed for hand control operated machines.

Hydraulic fluid comes out the port closest to the spool end of the valve when the spool is pushed in. Hydraulic fluid received at the fixed end of the cylinder pushes it out. When the hydraulic cylinder receives fluid at the ram (rod) end, it retracts.

# HYDRAULIC SCHEMATIC 1.1

1

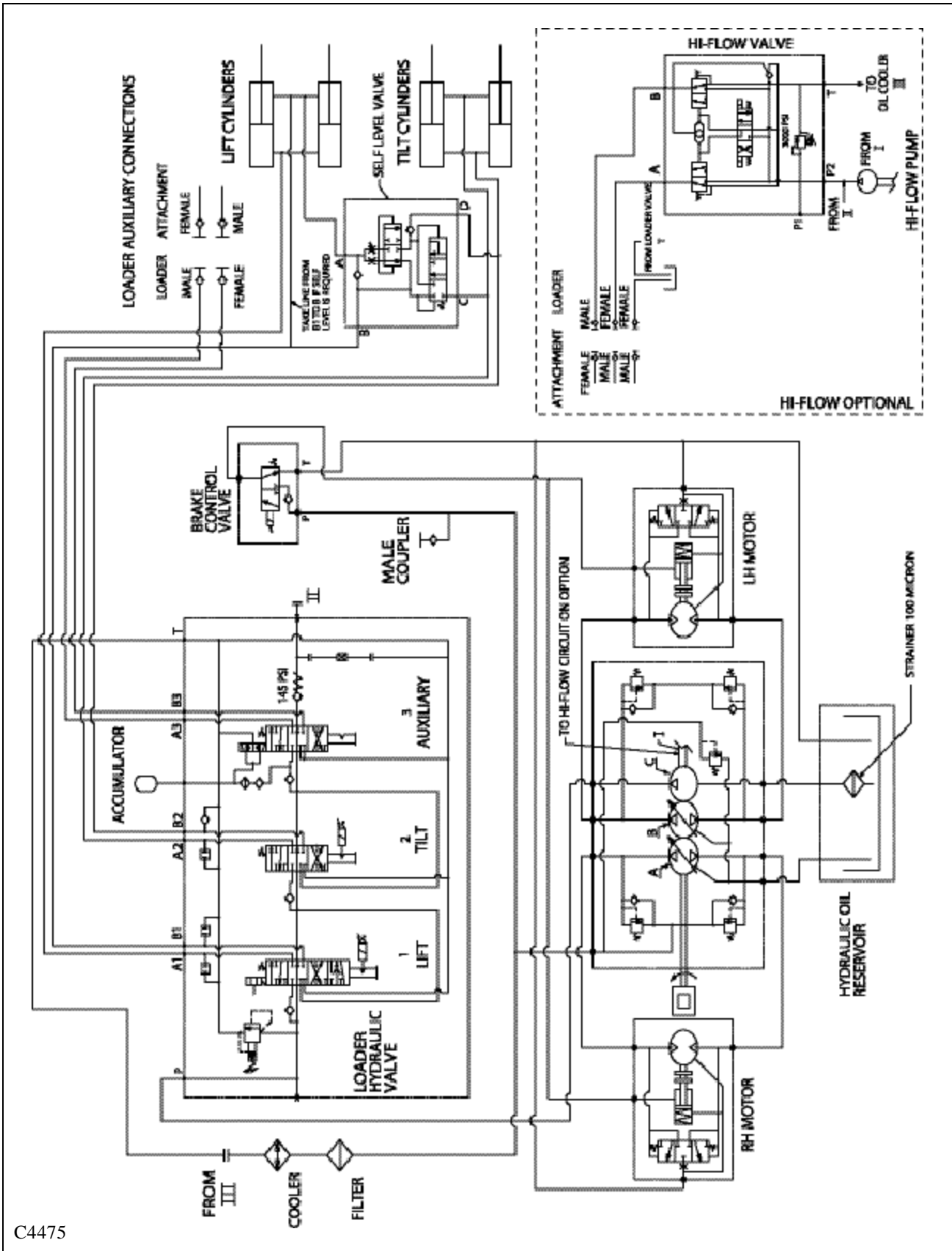

C4475

# 1

## – SPECIFICATIONS & MAINTENANCE 1.1 –

### Hydraulic Specifications

Pump Type	.....137/153 (Sauer-Danfoss) Gear, 1.37 cu in (22.5cc)
	..... 1300/135 (Eaton) / 1.2 cu in (19.7cc)
Pump Brand	..... Sauer Danfoss / Eaton
Pump Capacity	.....137/153 16.6 gal/min (62.8 l/min)
	.....1300/135 14.5 gal/min (54.9 l/min)
Control Valve	..... Series Type
Main Relief Pressure	..... 2400 psi (165.5 bar) @ Zero Flow
Reservoir Capacity	..... 8 US gallons (30.3 liters)
Fluid Type	..... 10W30 API SJ Oil
Reservoir Filtration	..... 100 Micron
System Filtration	..... 5 Micron
Oil Cooler	.....137/153 674 BTU
	.....1300/135 440 BTU
Lift Cylinders 153	..... (2) 2.5” Bore Diameter
Lift Cylinder Rods 153	..... 1.5” Diameter
Lift Cylinders 137/135/1300	..... (2) 2” Bore Diameter
Lift Cylinder Rods 137/135/1300	..... 1.25” Diameter
Tilt Cylinders	..... (2) 2 1/2” Bore Diameter
Tilt Cylinder Rods	..... 1.125” Diameter
Lift Cycle HD 135/153 Cyl. + / - 1.5 seconds (Up / Down)	..... 4.39 / 3.25
Lift Cycle STD 1300 Cyl. + / - 1.5 seconds (Up / Down)	..... 3.19 / 2.05
Tilt Cycle + / - 1.5 seconds (Up / Down)	..... 2.20 / 2.50

Allowable Drop, Measured at the Cylinder Rod, Engine Off,  
 @ Rated Capacity and Operating Temperature ..... 1.5” (38mm) / 3 Minutes

### Maintenance Schedule ..... First (HRS) ..... Every (HRS)

Oil level check	..... 8	..... 8
Oil filter change	..... 50	..... 150
Oil cooler clean	..... 8	..... 8
General system check		
( leaks etc. )	..... 8	..... 8
Cylinders, lubricate	..... 8	..... 8
Control valve relief filter	..... 500	..... 1000
Reservoir filters change	..... 1000	..... 1000
Hydraulic oil change	..... 1000	..... 1000

# GENERAL INFORMATION 1.1

Refer to figure C2018 on page 1-2.

Oil is drawn from the hydraulic oil reservoir through a 100 micron element. From there it travels to the main hydraulic pump.

- The hydraulic pump is a gear type which is driven by a shaft and coupler through the hydrostatic drive pump at engine speed. The oil then flows from the gear pump to the hydraulic control valve.

- The hydraulic control valve is equipped with an adjustable relief valve which is adjusted to 2400 psi (165.5 bar). The control valve is a series type with 3 spools (banks). The various spools activate the boom, bucket and auxiliary hydraulic functions.

When the spools are in neutral, oil flows from the hydraulic gear pump, through the control valve and returns to the hydraulic cooler, to the 5 micron hydraulic filter. From the hydraulic filter, the fluid flows to charge the tandem hydrostatic pump and pressurize the hydraulic brake release system and then back to the hydraulic reservoir. As a spool is moved, oil is directed to one of the valve ports and oil flows out to operate a function. The return oil coming back from this operation is ported to the next valve section which allows operation of more than 1 function at the same time. This is a series type valve function.

Each spool end contains a centering spring which returns the spool to neutral when the foot pedal, or control handle, is released.

- The boom section, on foot control operated loaders, has a detent mechanism to hold the spool in the float position. The auxiliary section is operated by foot pedal operation, or may have an optional electrical solenoid operated control, and may be engaged momentarily by the control lever mounted switch, forward or reverse, or by engaging the dash mounted toggle switch for constant power in the forward direction only.

The system relief valve operates when ever a hydraulic function has been restricted or overloaded (fig. C3746). To protect against excessive pressure build up, the relief valve opens and allows oil to return to the valve outlet. The system relief valve is adjustable, and is preset at 2400 psi (165.5 bar).

- Load check valves are located between the ports of each spool circuit. The function of the load check valve is to hold the boom arms or bucket in position during initial spool movement (fig. C3717).

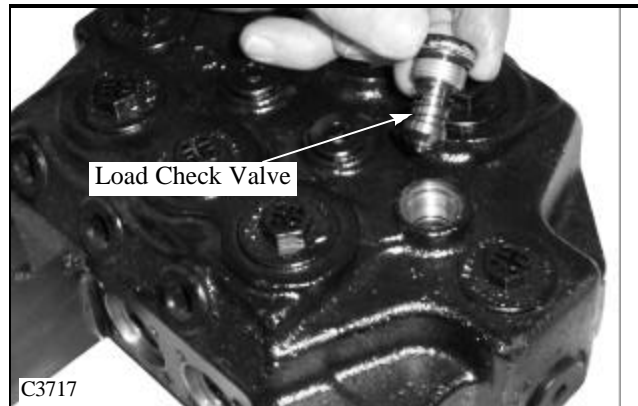
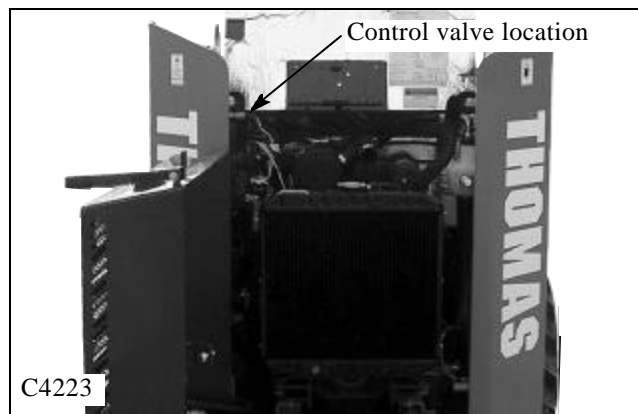
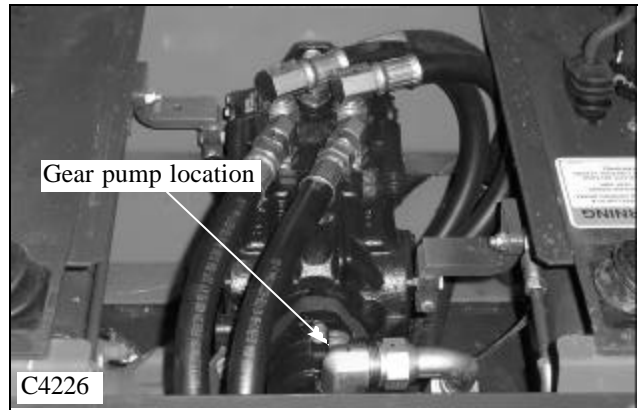

# GEAR PUMP 1.2

## 1

### Replacement

Start the gear pump removal procedure by removing any attachment, raising the boom arms and engaging the boom support pins. Shut off the engine.



#### WARNING

**To prevent personal injury do not work under the boom arms without the boom supports engaged.**

- 1 Remove the seat and hydrostatic shield.
- 2 Attach a vacuum system to the hydraulic oil reservoir filler location. ( fig. C4227 ) Or drain the oil reservoir. Seal the threads on the drain plug, if removed, with teflon tape or a liquid form of pipe sealant before re - installing.
- 3 Disconnect the hydraulic hoses from the gear pump. ( fig. C4228 ) Remove the pump fittings. Cap all open hoses to prevent contamination. After capping ends you may unhook vacuum system from oil reservoir.
- 4 Remove the 2 bolts holding the gear pump to the hydrostatic tandem section. ( fig. C4228b) Remove the gear pump.
- 5 Replace gear pump in reverse order.

#### IMPORTANT

**If gear pump replacement is being done because of failure, the hydraulic system and oil should be checked for contamination.**

- 6 If the hydraulic system has been contaminated by pump or other failure you must follow the cleaning procedure outlined in section 2.7.



#### WARNING

**Use caution when dealing with hydraulic fluid under pressure. Escaping fluid under pressure can penetrate the skin and cause serious injury.**

- 7 Start the engine and check for leaks. Do not use your hands to find leaks.
- 8 Check the fluid level in the hydraulic oil reservoir and replenish as required. (fig. C1878)

#### IMPORTANT

**When making repairs to the hydraulic system, keep the work area and parts clean. Use caps and plugs on all open lines and ports.**

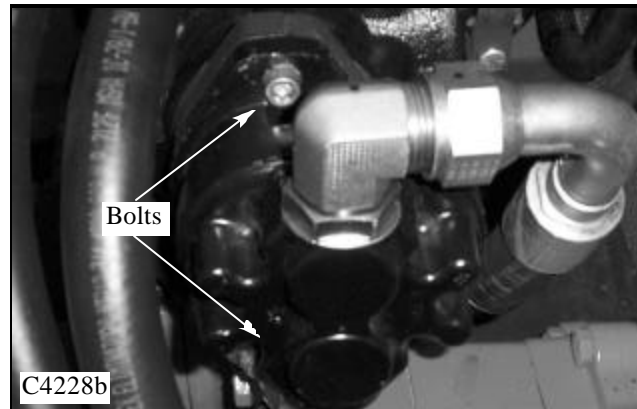
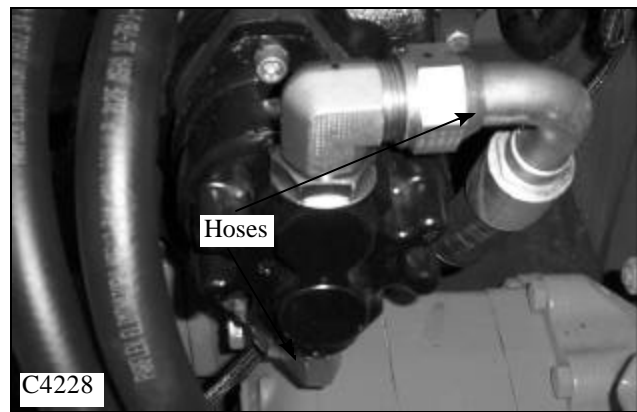
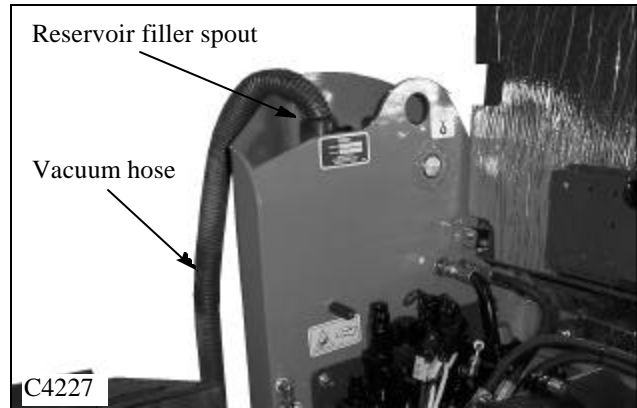



---

# GEAR PUMP 1.2

---

1

## Disassembly

### 1. General

The following is a detailed procedure for disassembly and assembly of the D series hydraulic gear pump. Prior to proceeding it may be necessary to prepare some sub-assemblies separately. The details for preparing each subassembly are given in the following section, as well as some general recommendations.

### 2. Cleanliness

Cleanliness is the primary factor for reliable pump performance. Wash the outside of the pump thoroughly before disassembly and all pieces prior to assembly. Cleaning parts with clean shop solvent and air drying is usually adequate.

### 3. Lubrication Of Moving Parts

During assembly, it is imperative to provide lubrication with clean hydraulic oil to all the running parts of the pump. It is also necessary to coat the seals with grease. The absence of lubrication during assembly can cause the unit to seize after a few minutes of running.

### 4. Care Of Surface Treatment

Be careful when handling all the internal surfaces, especially bearings, gears, and body faces. Do not touch or score them with metal tools or cutting edges.

### 5. Marking The Parts

Mark the parts before completely disassembling a pump. The marks allow components to be reassembled in the same relative position. This action should be applied to the body, bearings, and gears. Scribing, bluing, or using a felt pen to mark the outside of the body on the inlet side is suggested to indicate the relative position of the front flange and the rear cover to the body. Mark the bearing blocks also on the inlet side and the gears position relative to each other. DO NOT scribe internal surfaces.

#### **IMPORTANT**

**Mark all pieces during disassembly so that the unit can be reassembled correctly. Installing components incorrectly could severely damage the unit and/or cause it to not function properly.**

# GEAR PUMP 1.2

## 1

Disassembly 137/153

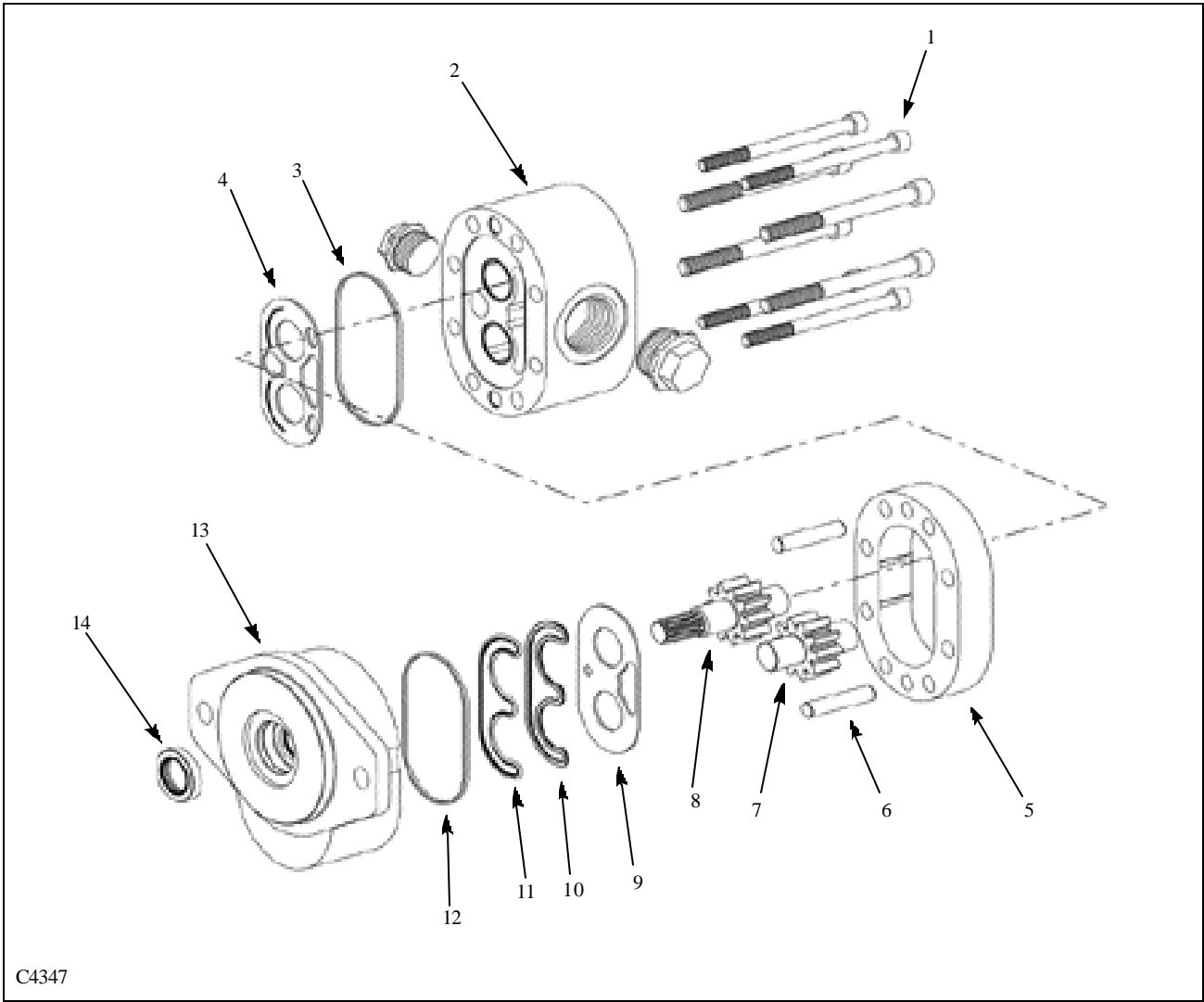

- |                   |                   |
|-------------------|-------------------|
| 1. Screws         | 8. Drive Shaft    |
| 2. Cover Assembly | 9. Wear Plate     |
| 3. Seal Ring      | 10. Load Ring     |
| 4. Wear Plate     | 11. Preload Ring  |
| 5. Gear Plate     | 12. Seal Ring     |
| 6. Dowel Pin      | 13. Body Assembly |
| 7. Idler Shaft    | 14. Shaft Seal    |

# GEAR PUMP 1.2

## Disassembly 137/153

### 6. Procedure

1. Clamp the unit in a vice from the flange side (fig. C4348). Make sure the vice jaws are clean and have smooth surfaces to prevent damage to the pump. Caution must be used when using a vice to avoid distorting any parts or damaging the mounting pilot.

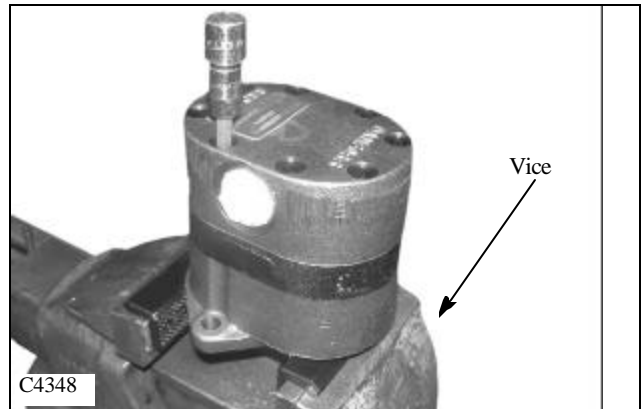

2. Use a Allen head socket wrench to loosen the bolts on the cover assembly (fig. C4349). Next completely unscrew the bolts and remove them. Inspect the threads for damage (fig. C4350).

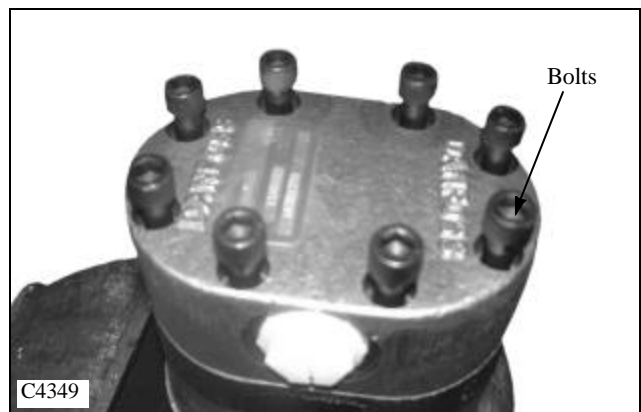

3. Slowly remove the cover assembly (fig. C4351). Note, some units have a shaft seal and others do not. Should your unit have the shaft seal, be careful not to damage it when removing the cover assembly.

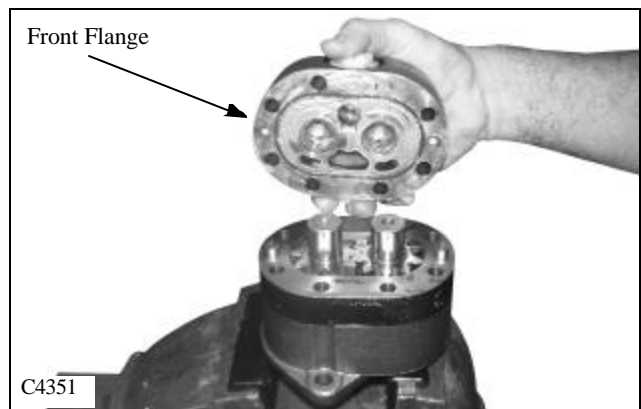
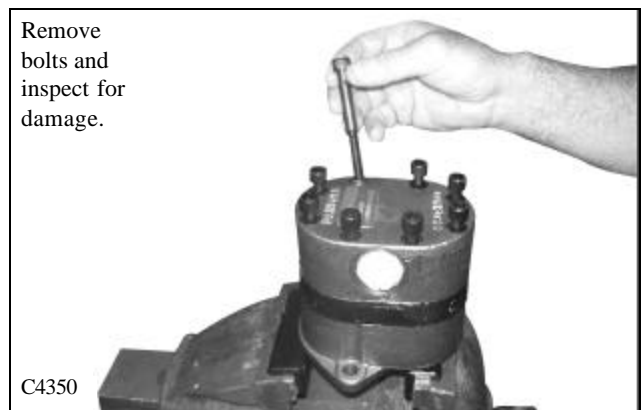

# GEAR PUMP 1.2

## 1

### Disassembly 137/153 (cont'd)

#### 6. Procedure

4. Place the cover assembly on the work bench (fig. C4352). Inspect the wear plate for evidence of extrusion or marks caused by overheating. Replace if necessary. Remove the wear plate and seal ring on the cover assembly. Do not use tools with sharp edges to remove the seal, as damage to the housing may result.

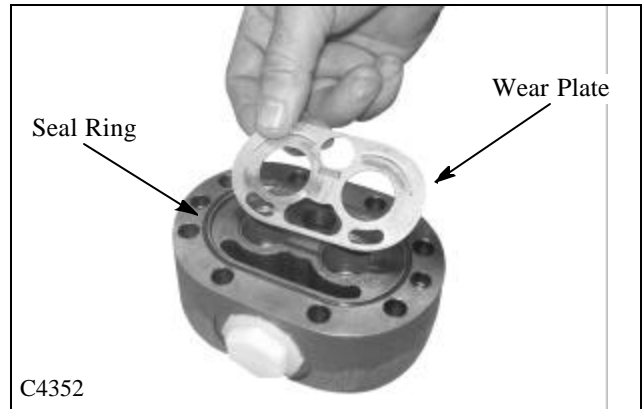

5. While disassembling the unit, you need to mark the relative positions of the gear mesh (drive gear tooth and idler gear tooth) and the body so they can be reassembled in the same position. Carefully remove the gear plate (fig. C4353). Remove the dowel pins and place in the gear plate.



6. Remove the idler shaft and drive shaft from its bearing bore. Inspect the journals and the flat faces top and bottom of the gears. Ensure these surfaces are free from burrs or scratches. If scratches are found, clean them with a flat stone and/or a very fine emery cloth. Rewash the gears with light oil after this operation.

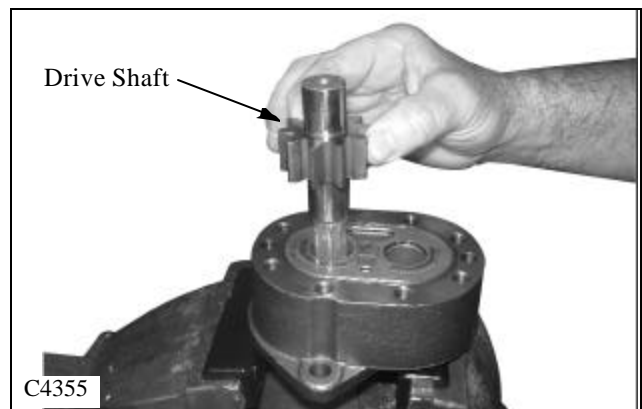
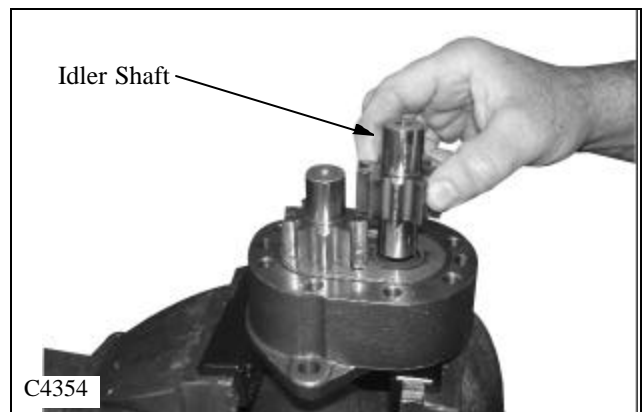

# GEAR PUMP 1.2

1

## Disassembly 137/153 (cont'd)

### 6. Procedure

8. Inspect the wear plate for evidence of extrusion, or marks caused by overheating. Remove the wear plate from the body assembly. (fig C4356) Replace if necessary. Remove the load ring, pre-load ring and seal ring. (fig C4357) Do not use tools with sharp edges to remove the seals, as damage to the housing may result. Dispose of any damaged seals.

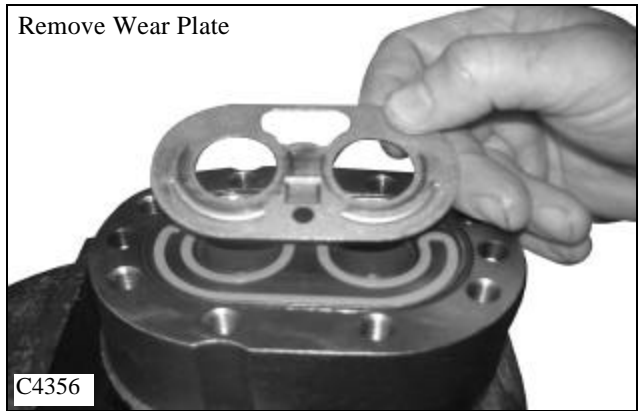

9. Remove the shaft seal in the body assembly (if applicable). Place the flange on the work surface. Using internal snap ring pliers, remove the snap ring. Check the seal quality and remove it if necessary. To remove, pry the bottom of the shaft seal and force it out while rotating the flange to lift it out evenly. Do not use the flange pilot to gain leverage as damage may result. Use a plastic rod or wooden dowel as a fulcrum. After removal, dispose of the damaged seal.



10. Complete disassembled unit. (fig C4358)

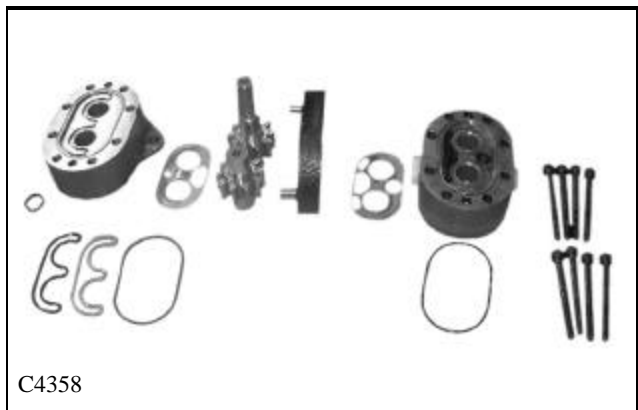

# GEAR PUMP 1.2

## 1

### Assembly 137/153

1. Have the entire seal kit available and lay out neatly on the table (fig. C3980). Compare the old seal kit to the new one to ensure you have the correct one. Lightly coat all seals with seal grease. The grease is needed to adhere the seals in their grooves. **DO NOT INSTALL DRY SEALS!**

2. Prepare the body by cleaning it. Inspect the internal and mating surfaces. Ensure the surfaces are free of burrs and scratches.

3. Install the shaft seal into the body assembly (if applicable). Prepare the body and shaft seal by lightly lubricating with grease. Seat the seal in the body assembly by hand. Then, using a shaft seal installation tool press the seal until the tool stops on the flange. This will insure the seal is inserted to the proper depth.

3. Place the body assembly, with the E- ring seal grooves facing up, into a vice with soft jaws. Caution must be used when using a vice to avoid distorting or damaging the mounting pilot.

4. Place the rubber seal ring in the body groove. (fig. C4359)

5. Place the pre-load seal (black rubber E-ring) into the body E-ring groove. (fig. C4360)

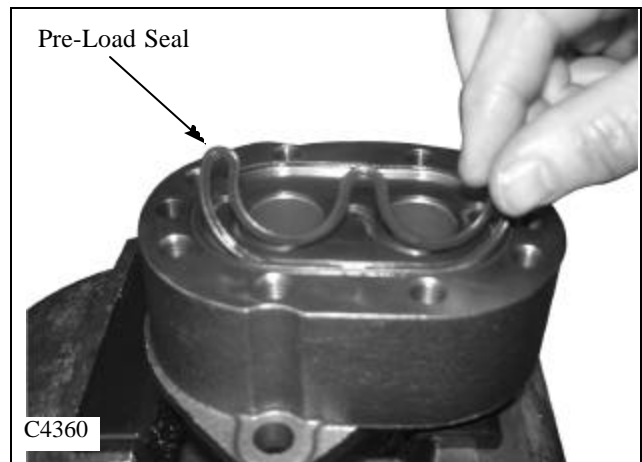
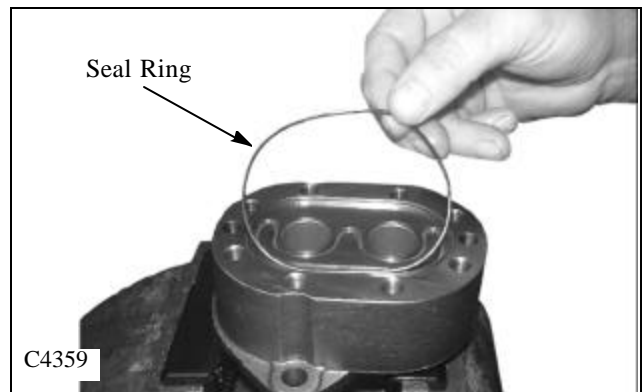
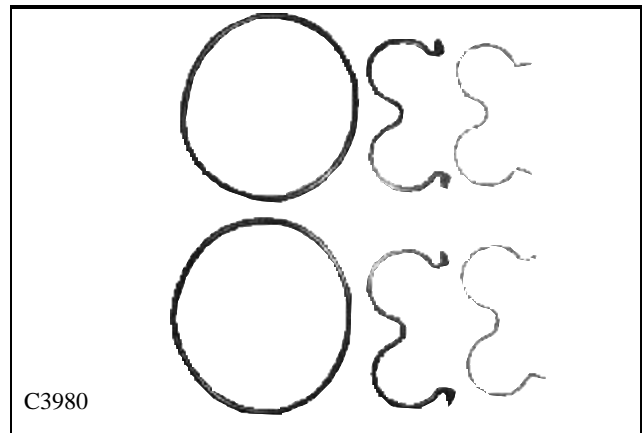

# GEAR PUMP 1.2

## Assembly 137/153 (cont'd)

1

6. Place the load seal directly on top of the pre-load seal (blue E-ring).

7. Find the wear plate with a 0.25" diameter pressure hole and no oblong holes on the inlet side. Place the wear plate on top of the load ring with the bronze side facing up towards the gear. The 0.25" pressure hole is to be positioned on the E-ring side of the body. (fig C4356)

8. Lubricate the spline end of the drive shaft with Aerolube grease. Insert the drive shaft in the correct bearing bore. Align the idler shaft with the assembly marks to ensure assembly is installed with the same orientation as before assembly. Place the idler shaft in the correct bearing bore into the body (fig. C4354). Inspect gear teeth for alignment. Misaligned gear teeth may increase operating noise. Lubricate the complete gearset using clean light oil.

9. Insert the two dowel pins into the body assembly. Place the gear plate over the dowel pins and lightly tap making sure it contacts the body. (fig. C4353) Check to make sure the gear plate is seated properly with no foreign pinched between these surfaces.

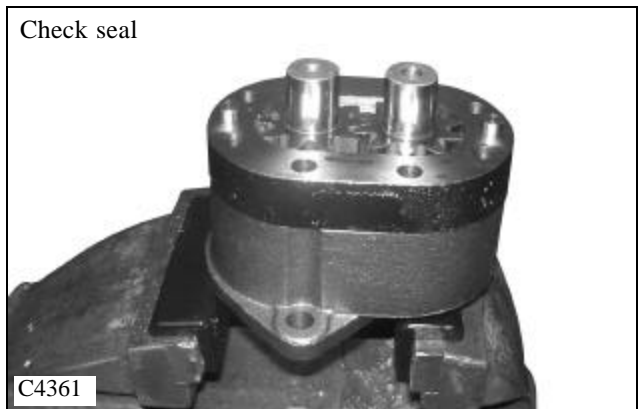
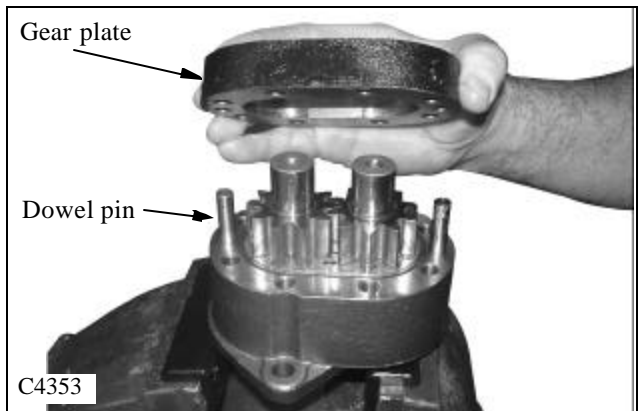
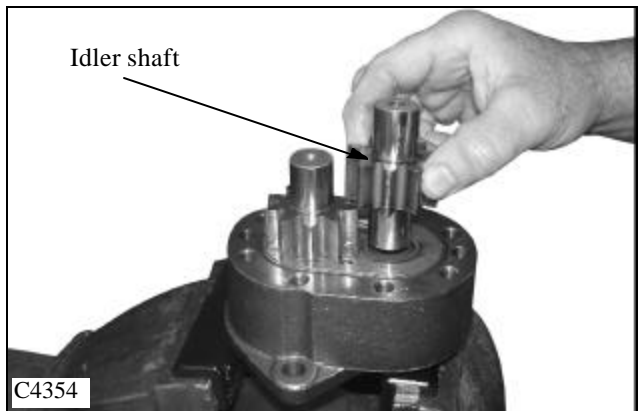
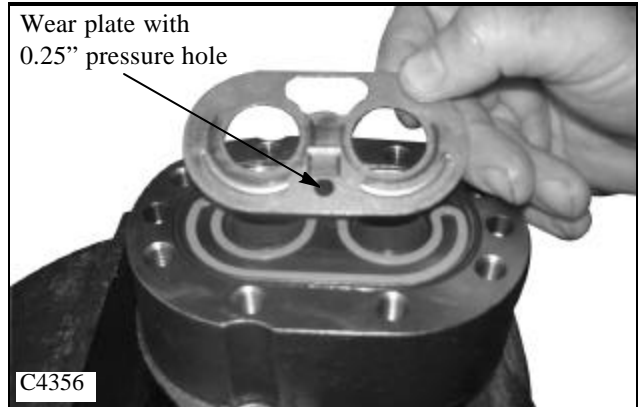

# GEAR PUMP 1.2

## 1

### Assembly 137/153 (cont'd)

10. Place the cover assembly on a bench with the machined surface facing up. Place the rubber seal ring in the cover seal ring groove. (fig C4362)

11. Find the wear plate with the 0.625" diameter pressure hole and two oblong holes on the inlet side. Position the wear plate in the cover with the bronze side facing up (towards gears) and the 0.625" pressure hole located over the circular holes in the cover. (fig. C4352)

12. Line up the cover assembly with the shaft journals and dowel pins (fig. C4351). Lightly tap the back of the cover until dowel pins are completely engaged. Check the seal making sure it is seated properly with no foreign material pinched between the surfaces.

13. Place the screws in the cover holes and turn until the treads engage. Use care so that cross threading does not occur.

14. Torque the four bolts in a crossing pattern a little at a time until you reach the final torque of 47 ft lbs. (65 Nm) (fig. C4363)

15. After the pump has been disassembled and reassembled it is suggested that the pump be run in and tested on an appropriate test stand. This is done to verify the volumetric efficiency and the integrity of the unit.

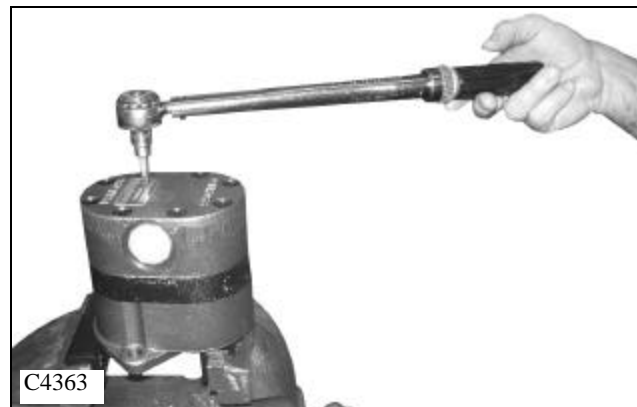
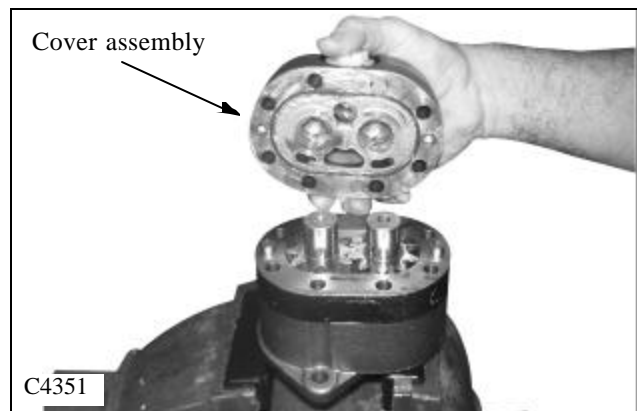
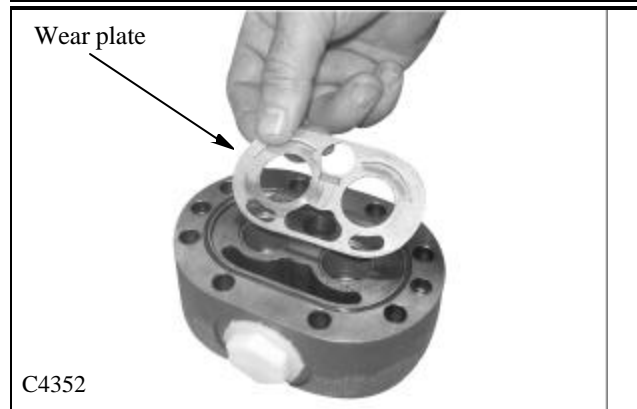
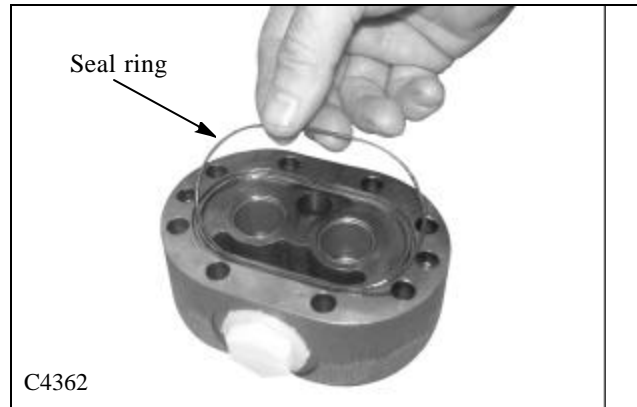



# GEAR PUMP 1.2

Disassembly 1300/135

1

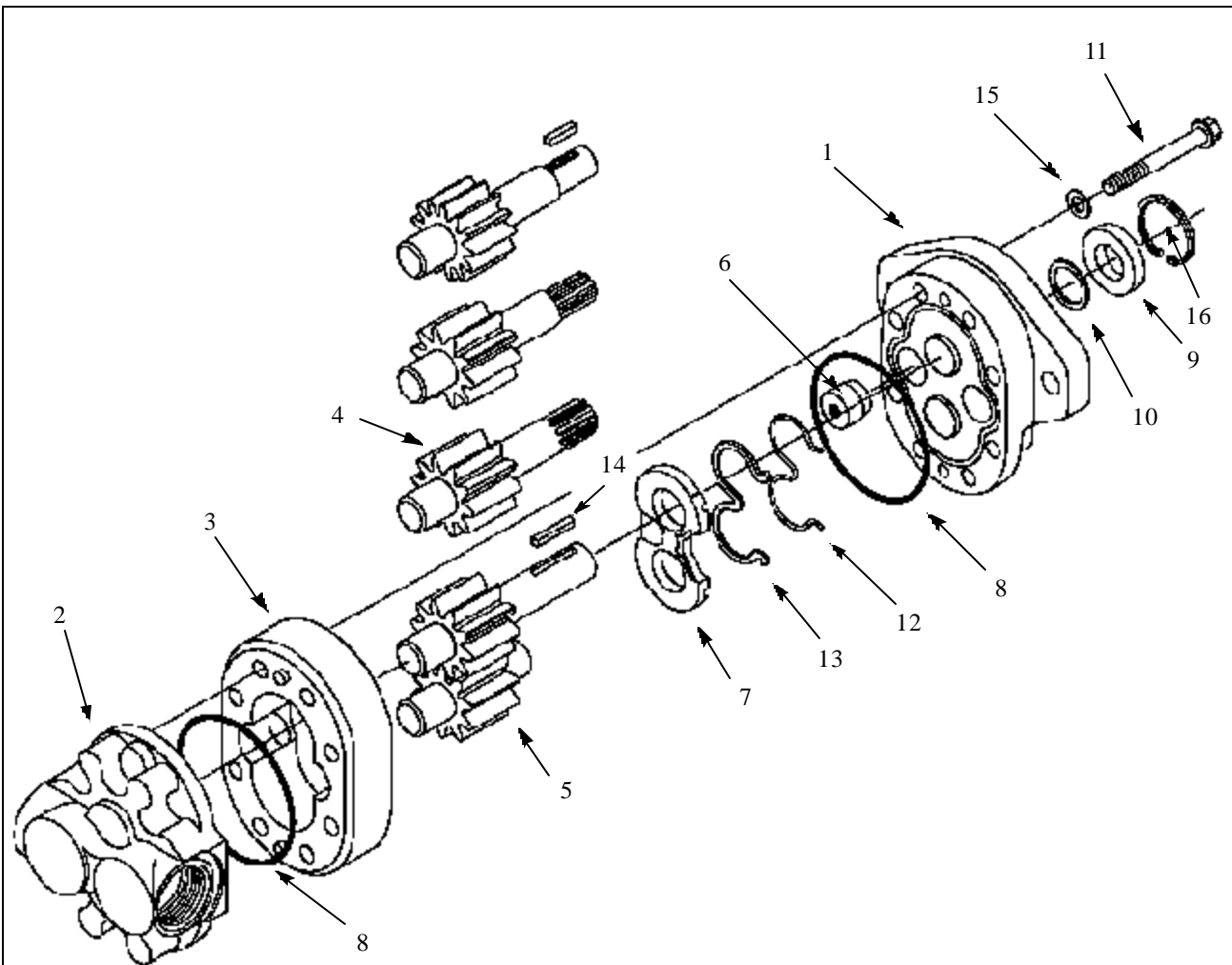

1. Front Plate Assembly
2. Back Plate
3. Body Assembly
4. Drive Gear
5. Idler Gear
6. Plug
7. Wear Plate
8. O - Ring Seal

9. Shaft Seal
10. Washer
11. Cap Screw
12. Back up Gasket
13. Seal
14. Key for Straight Shaft Models
15. Washer
16. Retaining Ring (optional)

# GEAR PUMP 1.2

## 1

### Disassembly 1300/135

Remove the gear pump as outlined on page 1-6. Work in a clean area. Thoroughly clean the outside of the gear pump before disassembly. Remove the adapter fittings from the gear pump and drain the oil.

- 1 Remove the key from the drive gear if so equipped.
- 2 Using a grease pencil or equivalent, place a mark across the front plate, body and back plate to assure proper alignment when reassembling.
- 3 Place the gear pump in a vise with the shaft side up. (fig. C2090)

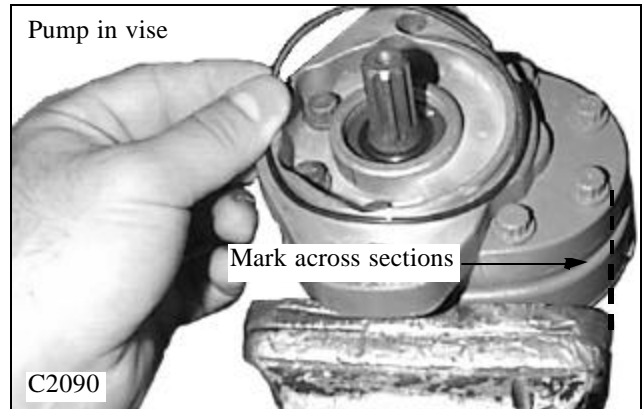

- 4 Remove the cap screws and washers retaining the pump sections together. (fig. C2089)

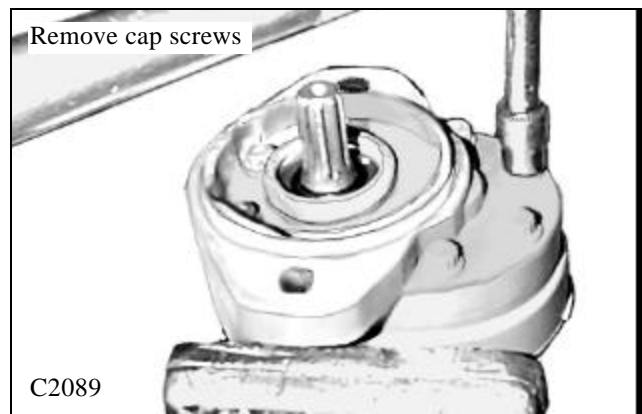

- 5 Remove the gear pump from the vise. Tap the shaft using a plastic hammer to separate the front plate from the back plate. The body will remain intact with one of the plates. (fig. C1895)

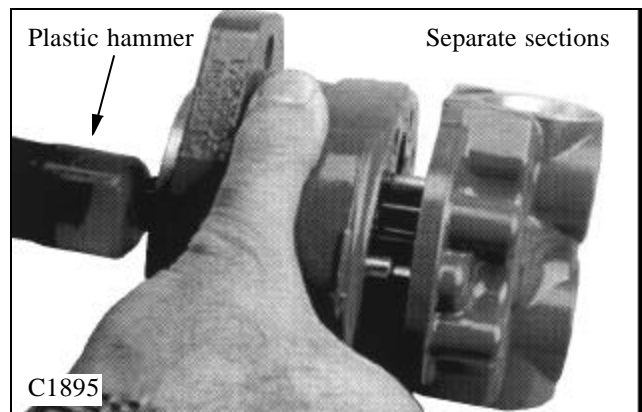

- 6 Remove the O - Ring seal from the back plate. (fig. C1896)

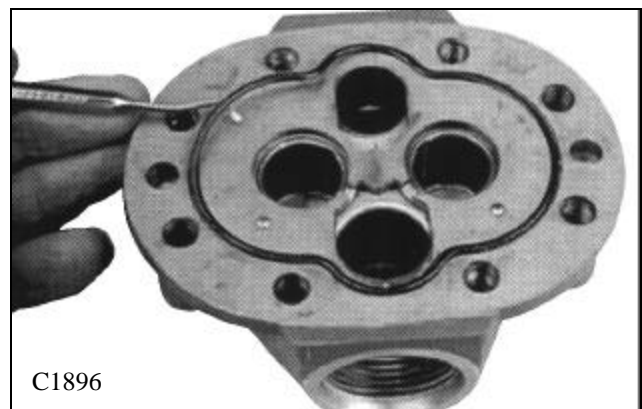

# GEAR PUMP 1.2

1

## Disassembly 1300/135 (cont'd)

- 7 Remove the idler gear assembly from the body.
- 8 To separate the body from the plate, replace the drive gear assembly in the gear pocket and tap the protruding end with a plastic hammer. (fig. C1897)

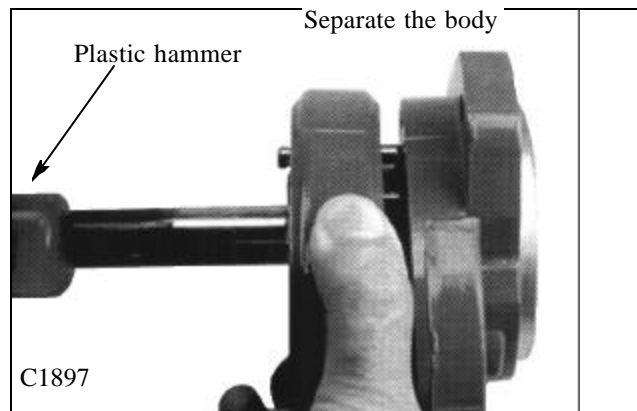

- 9 Remove the wear plate and O - ring seal, noting the position of the open side of the wear plate. (fig. C1899)

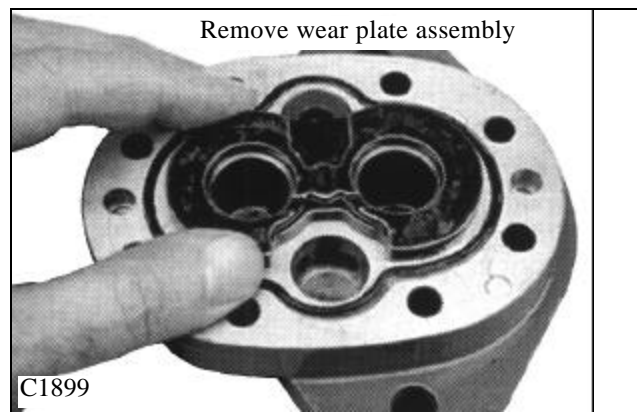

- 10 Remove the back up gasket and seal from the wear plate by extracting with an O - ring tool. (fig. C1898)
- 11 Remove the snap ring, if used, from the front of the front plate shaft seal area.

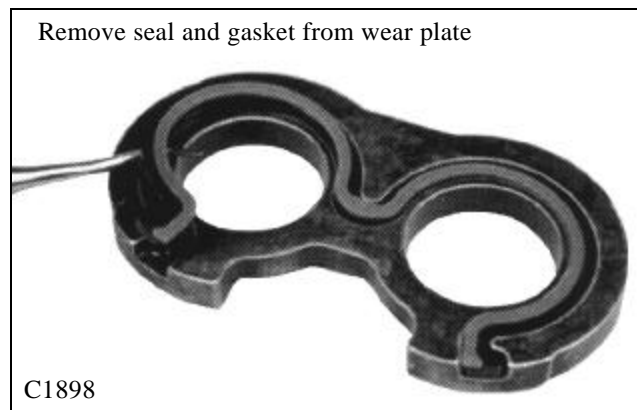

- 12 Remove the shaft seal and washer from the front plate using a blunt punch from the back side. (fig. C1900)

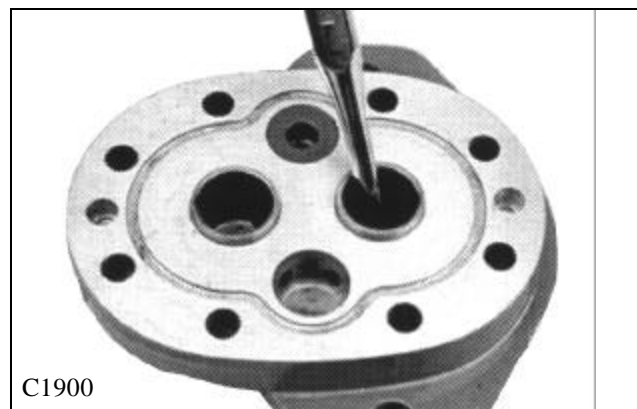

# GEAR PUMP 1.2

## 1

### Assembly 1300/135

It is important that the relationship of the back plate, body, wear plate and front plate is correct upon reassembly. Note the 2 (two) half moon shaped cavities in the body. The smaller half moon port cavity must be on the pressure side of the gear pump. The side of the wear plate with the mid section cut out must be on the suction side of the gear pump. The suction side of the back plate is always the side with the larger port boss.

1 During reassembly replace the wear plate, seal back up gasket, shaft seal and O - rings with new parts.

2 Install the O - ring in the groove of the front plate. (fig. C2000)

3 Apply a thin coat of petroleum jelly to the machined gear pockets of the body. (fig. C2001) Install the body to the front plate. Make sure the small half moon shaped cavity in the body faces the pressure side (plugged side) of the pump.

4 Install a new seal and back up gasket to the wear plate. (fig. C2002) Note in the middle of the back up gasket a flat section or support. This area must face away from the wear plate, inside the seal.

5 Place the new wear plate, seal and back up gasket into the gear pocket with the seal and back up gasket next to the front plate. (fig. C2003) The side of the wear plate with the mid section cut away must be on the suction side of the pump.

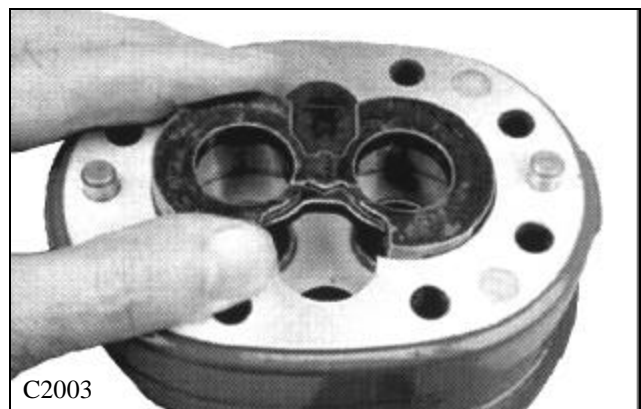
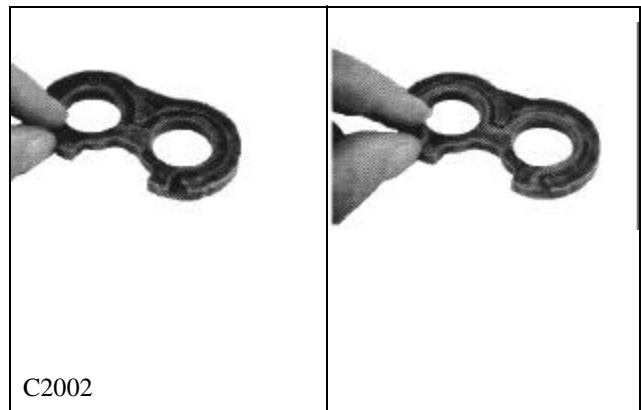
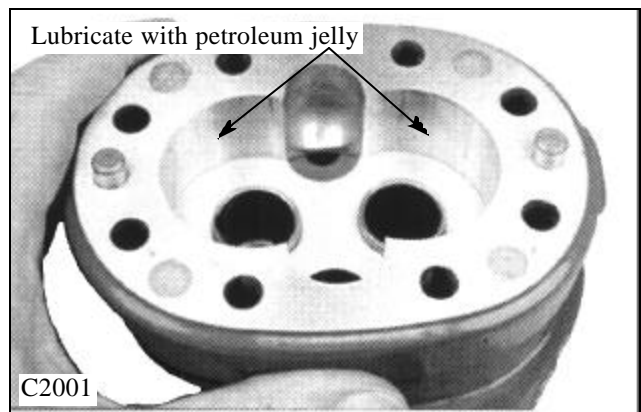
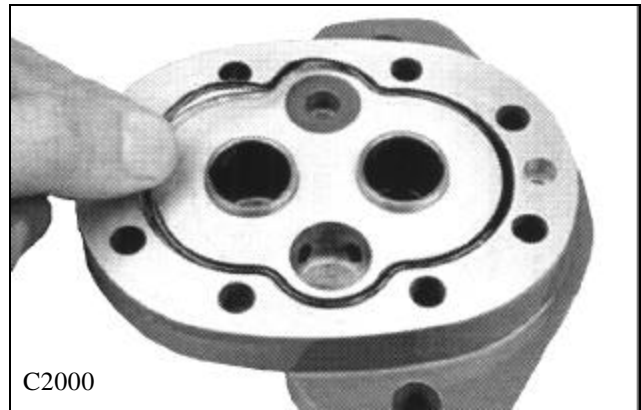

# GEAR PUMP 1.2

1

## Assembly 1300/135(cont'd)

6 Dip the gear assemblies with system oil and slip the gears into the front plate bushing and body. (fig. C2004)

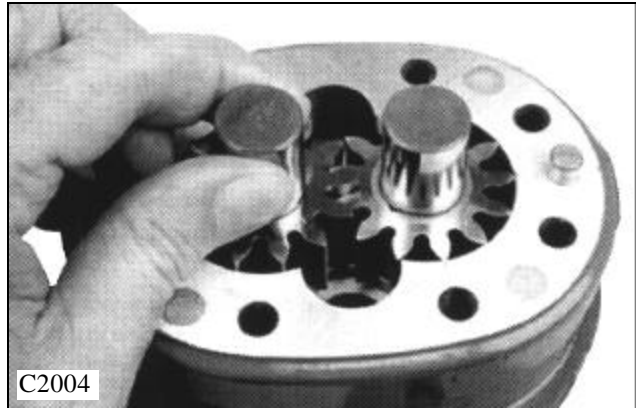

7 Install a new O - ring in the groove of the back up plate. (fig. C2005)

8 Make sure the port orientation is correct and then slide the back plate over the gear shafts until it is down over the dowel pins. The large port opening in the back plate is the inlet side.

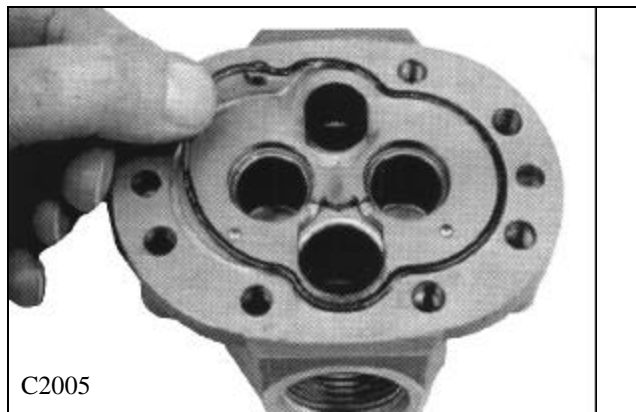

9 Install the cap screws and washers. (fig. C2089)  
Torque the evenly in a crisscross pattern to 25 ~ 28 ft lbs (34 ~ 38 Nm).



10 Place the washer over the drive shaft into the housing. Lubricate the seal liberally with system oil and install over the drive shaft. (fig. C2006) Use caution to avoid cutting the seal lips while installing the seal over the drive splines.

11 Place a 1- 5/16'' O.D. sleeve over the shaft and press the shaft seal into the housing until flush with the front surface of the front plate. Note: If so equipped, some models may require a retaining clip (snap ring) installed.

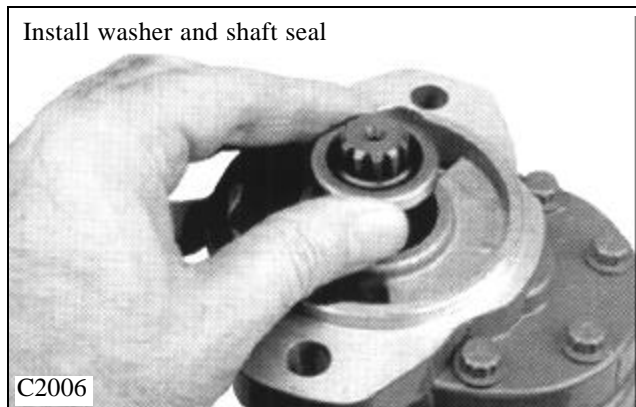

# GEAR PUMP 1.2

# 1

## Assembly 1300/135 (cont'd)

12 Install a new O - ring onto the gear pump mounting surface. (fig. C2090)

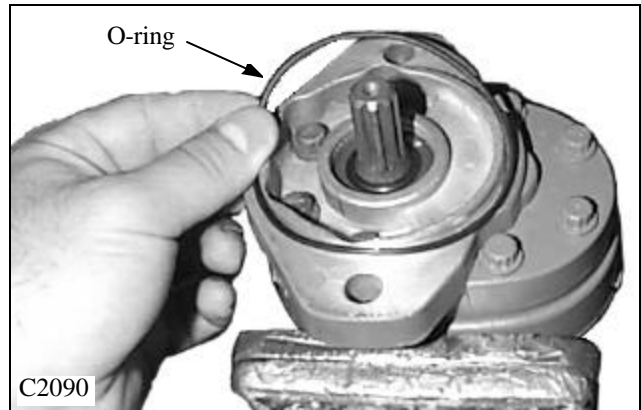

13 Install the adapter plate, new O - ring and shaft coupler. (fig. C2091)

14 Install the gear pump to the loader as outlined on page 1-6.

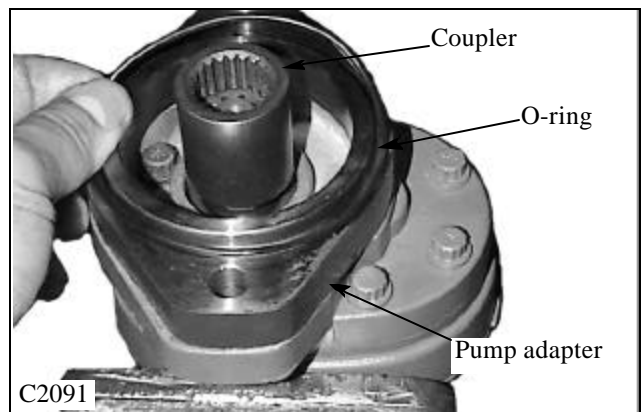

## Start up Procedure

- 1 Mount the gear pump to the loader. (fig. C4228)
- 2 Connect the hydraulic lines.
- 3 Start the pump and run for 3 minutes each @ zero flow.
  - a. Half speed at zero flow
  - b. Half speed, intermittently loaded to 500 psi (35 bar)
  - c. Full speed, intermittently loaded to 1000 psi (69 bar)
- 4 Check for leaks.

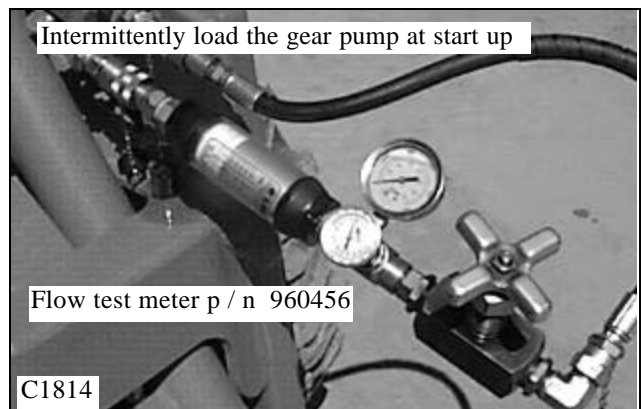

# CONTROL VALVE 1.3

## Testing and Adjusting the Relief Valve Pressure

Hoses and gauges required for this test must be capable of withstanding 5000 psi (345 bar) continuous pressure, and hydraulic flow meter capable of measuring 30 gallons per minute. (113 l/min) (fig. C3432) **This test also checks the status of the gear pump capacities.**

Pressure fluctuations may be caused by restricted oil flow through the relief valve. The relief valve may need replacing when its filter is contaminated.

1 Install the flow meter / pressure tester to the auxiliary hydraulic quick couplers. The female coupler attached to the loader provides the power out when the auxiliary control is engaged. (fig. C4229) Connect the flow meter and pressure gauge inlet side to match the power out of the female auxiliary coupler to prevent meter and gauge damage. Be sure to connect a return line to the male auxiliary hydraulic quick coupler. (fig. C4230)

2 Start the engine and engage the auxiliary hydraulic system. Increase the engine speed to full operating prm. (See Section 7 for checking and adjusting engine speed)



### CAUTION

Adjusting the relief valve setting too high may cause damage to the gear pump.

3 Turn the flow control valve on the flow meter to restrict the oil flow down to 2 gal /min. (7.5 l/min ) As you are turning the flow control valve, watch the pressure gauge and make sure it does not go over 5000 psi (345 bar). Stop further adjustment immediately if the reading goes over this setting. Shut off the auxiliary hydraulic system and shut off the engine. Move to step 6 to make initial setting.



### WARNING

To prevent personal injury or damage to the loader, do not adjust the relief valve while the engine is operating.

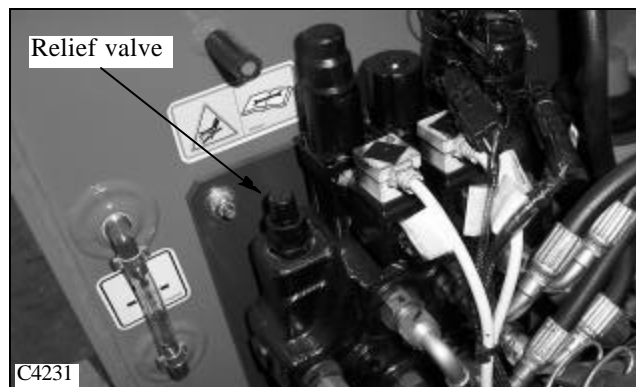
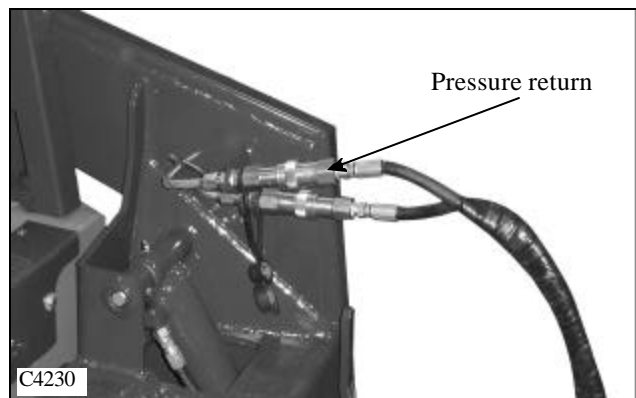
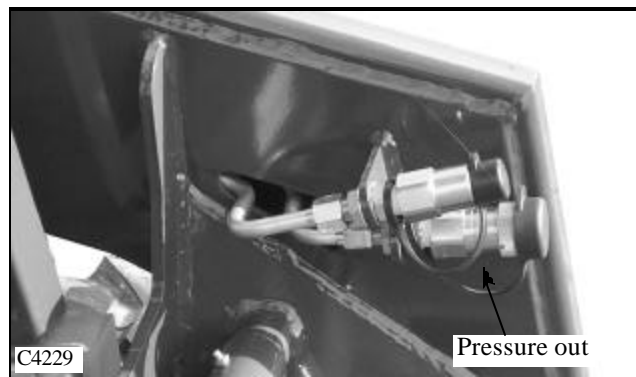
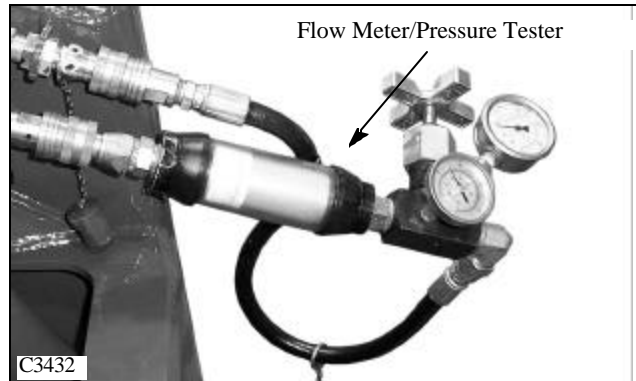

# 1

## CONTROL VALVE 1.3

4 Repeat steps 2 and 3 if necessary. Allow the loader to operate at this setting until the oil temperature has increased to 160° F (71°C), operating temperature.

5 Turn the flow control valve further to restrict the oil flow to no flow. (Zero) Correct pressure setting is 2400 psi +/- 100 psi (165 bar +/- 6.9 bar).

6 If adjustment is necessary, shut down the auxiliary hydraulic system, shut off the engine and return the flow control valve to the open position. Locate the control valve in the engine compartment.

7 Loosen the jam nut on the relief valve adjusting screw and turn the screw clockwise, counting the turns, until the screw bottoms out. (fig. C4233)

8 Turn the screw back. Reduce the number of turns that you turned in to increase the pressure, increase the number of turns to decrease the pressure.

9 Retake the pressure readings by performing steps 2 through 5. If necessary make further adjustments by repeating steps 6 through 9.

**NOTE: If adequate pressure and / or flow is not available, the gear pump could be failing, the intake to the gear pump is restricted, or the filter in the relief valve is clogged.**

### Control Valve Replacement

1 Remove any attachment and shut off the engine. Turn the key on with the safety devices activated so the pedals can be moved. Slowly jog both pedals and press the electric auxiliary switch. This will take any pressure out of the system.

#### IMPORTANT

**Clean the work area prior to repair. Cap all open lines, fittings and ports to prevent contamination.**

2 Disconnect the control cables, electrical solenoid spool locks, and electrical auxiliary solenoid wiring connectors if equipped. (fig. C4234, C4235)

3 Disconnect the the inlet hose coming from the gear pump. Cap the hose and fitting and remove the adapter fitting in the control valve. (fig. C4234)

4 Disconnect the 6 hoses going to the boom, bucket and auxiliary circuits. Marking the hoses as you remove them is recommended to ease re-assembly and assure the circuits are functioning properly at restart.(fig. C4445)

5 Disconnect the accumulator line from the electric auxiliary circuit and remove the adapter fitting. Plug and cap all open ports and hose ends.

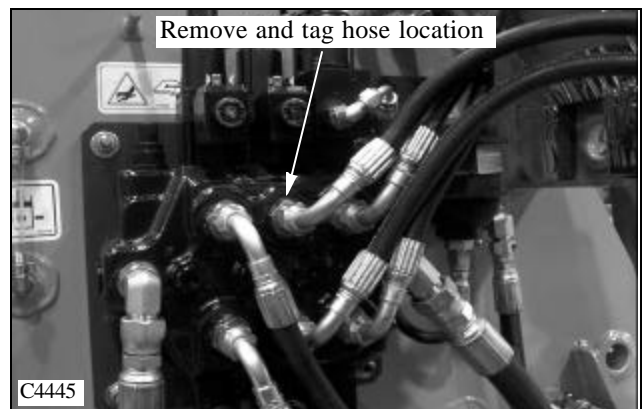
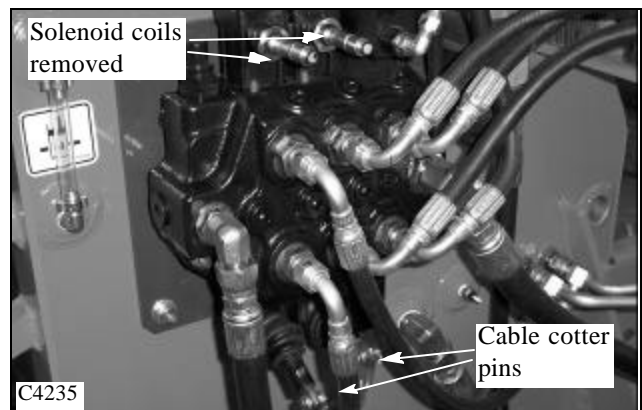
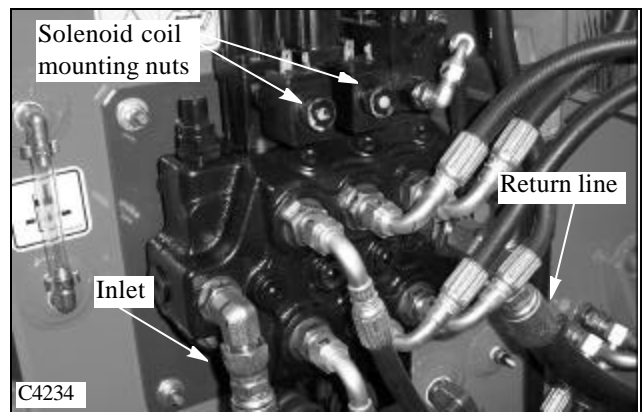
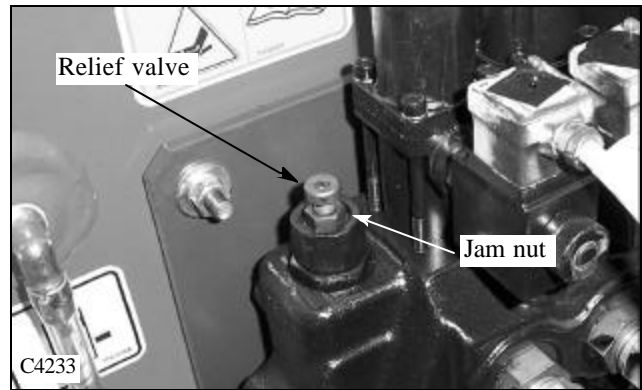



# CONTROL VALVE 1.3

6 Disconnect the return line from the control valve and remove the adapter fitting. Plug and cap all open ports and hose ends.

7 Remove the 3 nuts holding the control valve to the mount and remove the control valve.

8 Remove any fittings left in the control valve. Cap all open ports to prevent contamination. Place these fittings in the new or repaired control valve. Be sure to check all fitting flares and o-rings for damage and replace as required.

## IMPORTANT

Follow the hydraulic fitting torque chart in Section 1.10 when connecting fittings and lines.

9 Assemble the control valve to the loader in the reverse order above. Torque the bolts holding the control valve to the mount at 15 ft lbs. (20.4 Nm)

10 After all connections have been made, including the control valve electrical connections, check the oil level in the hydraulic reservoir and top off if necessary.



## WARNING

Use extreme caution when checking the hydraulic system for leaks. Fluid under pressure can penetrate the skin and cause serious injury.

11 Start the engine and cycle the various hydraulic functions to check for leaks. Make sure the control valve lock system is functioning properly. Do not use your hands to check for leak locations, fluid under operating pressure can penetrate the skin and cause serious personal injury.



## WARNING

All safety switches must be connected and functioning to prevent possible operator injury.

12 After checking for leaks, you must retest the relief valve setting as outlined on page 1-6 Testing and adjusting.

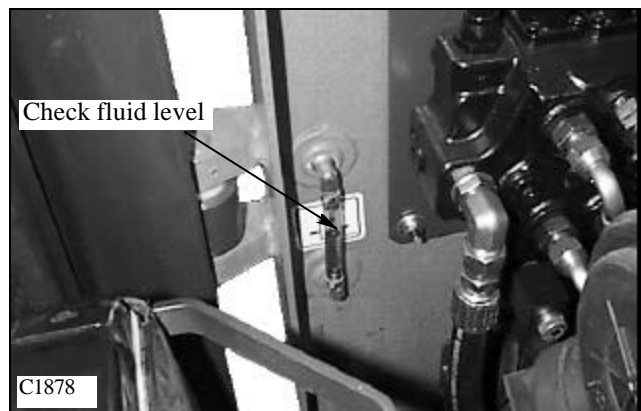
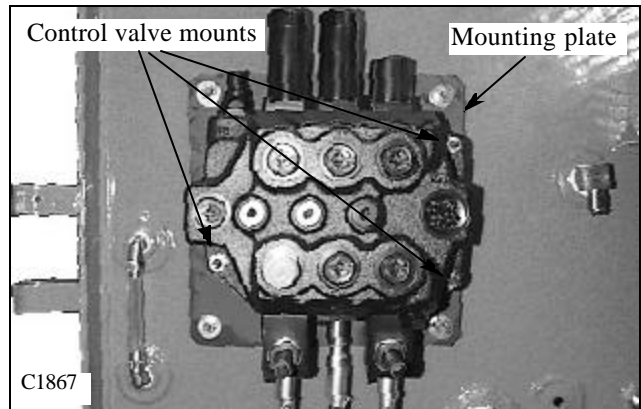

# 1

## CONTROL VALVE 1.3

### Control Valve Disassembly 137/153

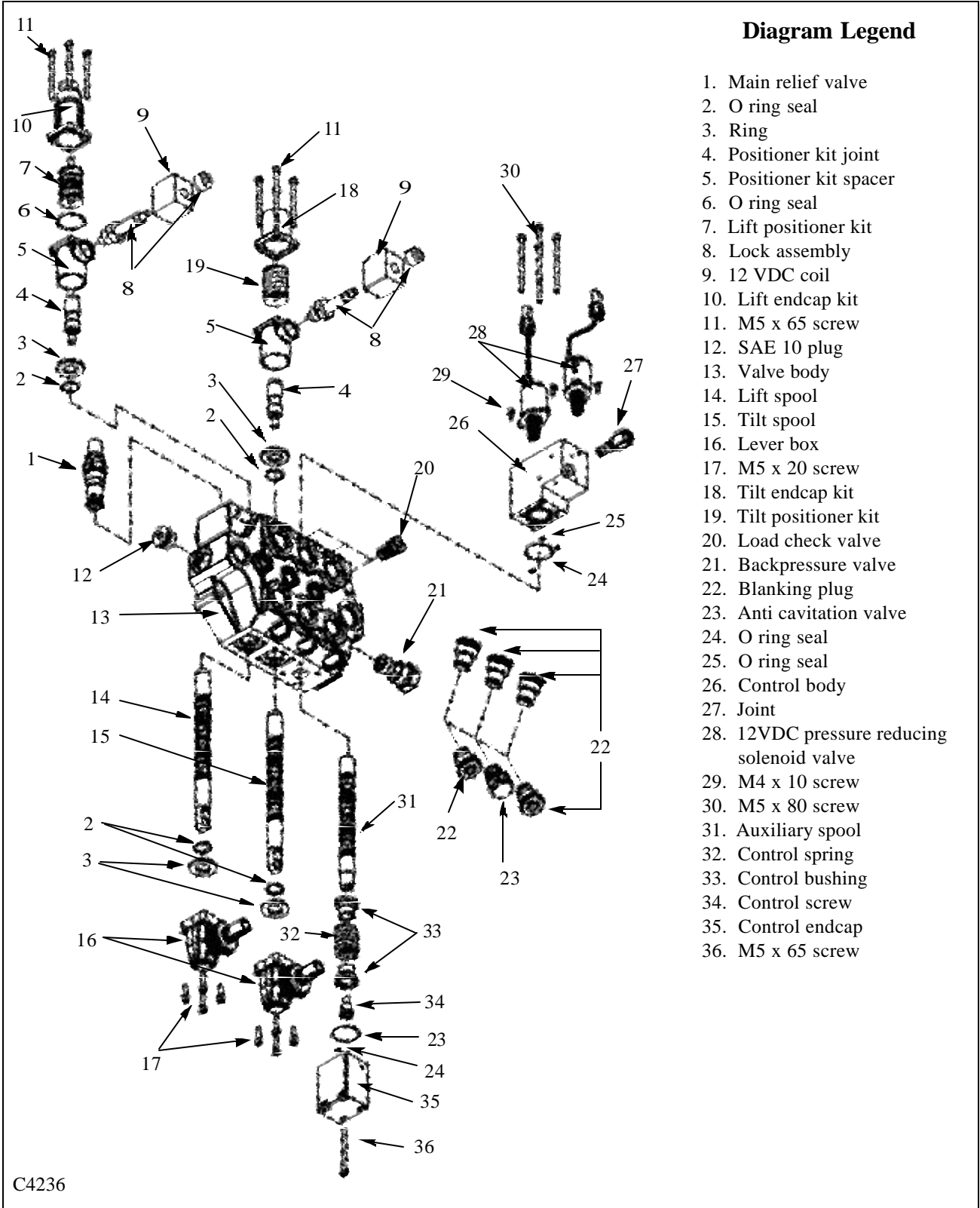

# CONTROL VALVE 1.3

## Control Valve Disassembly 1300/135

1

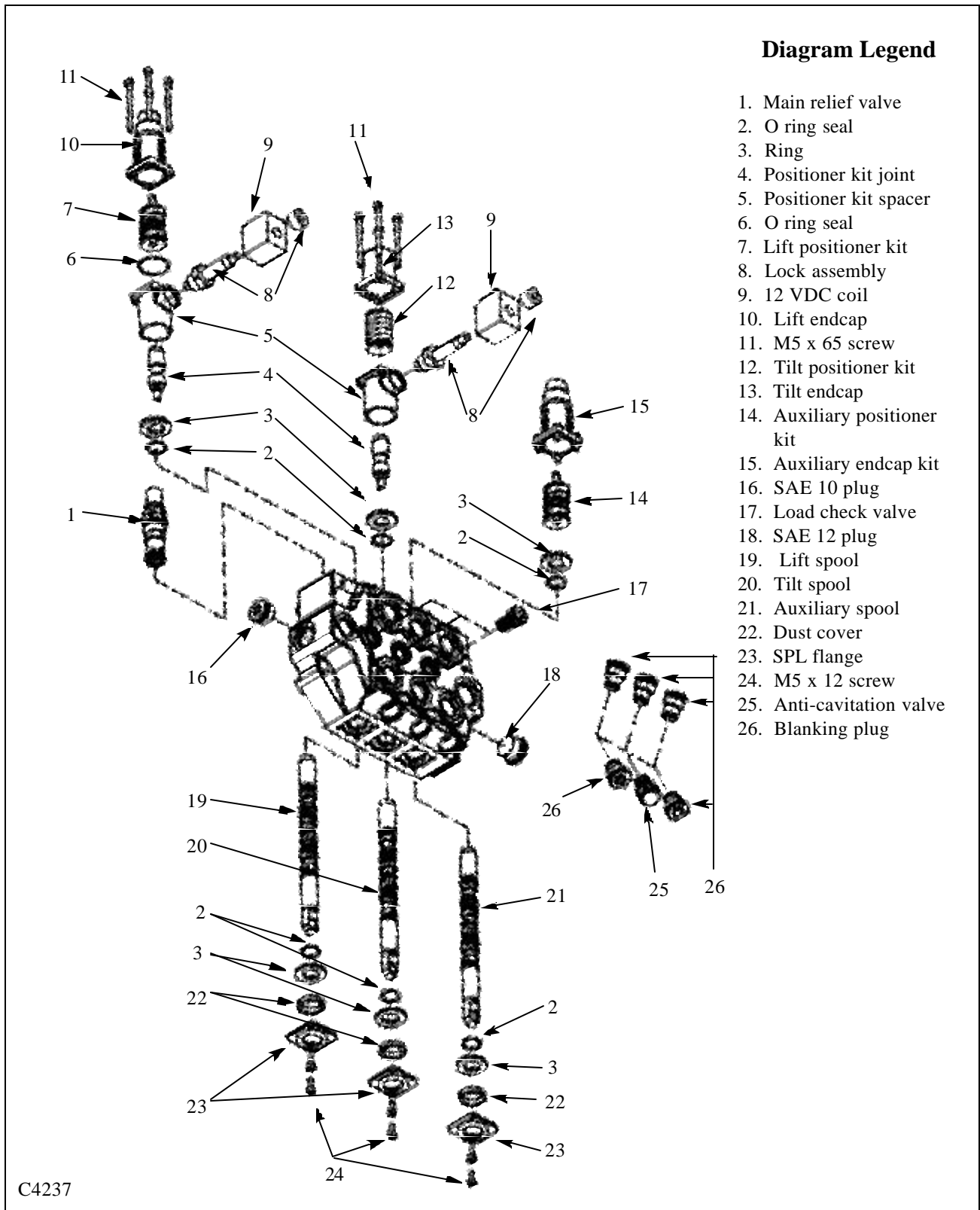

# CONTROL VALVE 1.3

# 1

## Disassembly / Repair 137/153

Before disassembling the hydraulic control valve, clean the body with a suitable solvent and dry with compressed air. (fig. C3696)



### WARNING

To avoid eye injury, use safety goggles when cleaning with compressed air.

Ensure all openings are plugged to prevent solvents and dirt from contaminating the control valve assembly.

1. Remove the pressure relief valve. Discard the O-rings. (fig. C3698)

2. Remove the solenoid coils and locking pin from the valve lock block. (fig. C3699 ) There are 2 O-ring seals located on either side of the solenoid coils (fig C805).

3. Remove the spring return detent kit and spring center cap locks. (fig. C3704, C3706)

Control Valve



C4254

Removing the Relief Valve

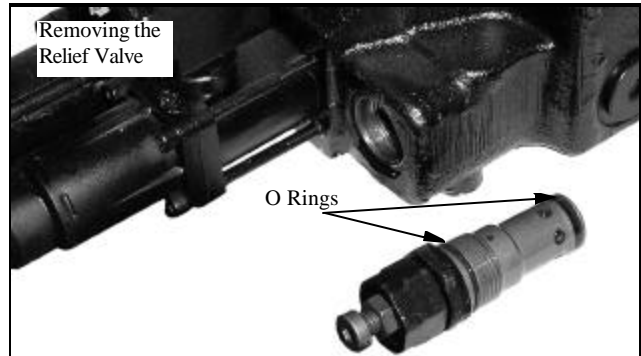

C3698

Removing the solenoid coils from the spool locks.

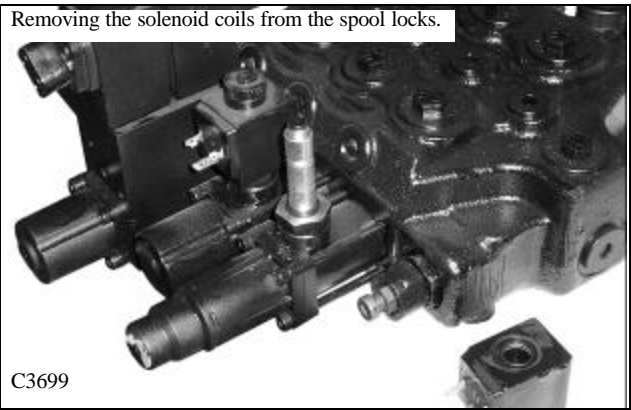

C3699

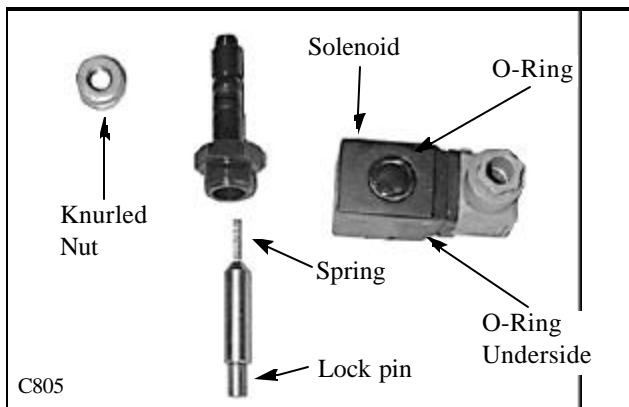

C805



C3704

# CONTROL VALVE 1.3

1

## Disassembly / Repair 137/153 (cont'd)

4 Remove the control box from the spool linkage end. (fig. C3709) The box needs to be tilted upward towards the valve to release the hardened ball from the hole in the spool end, and then pull away from the valve.

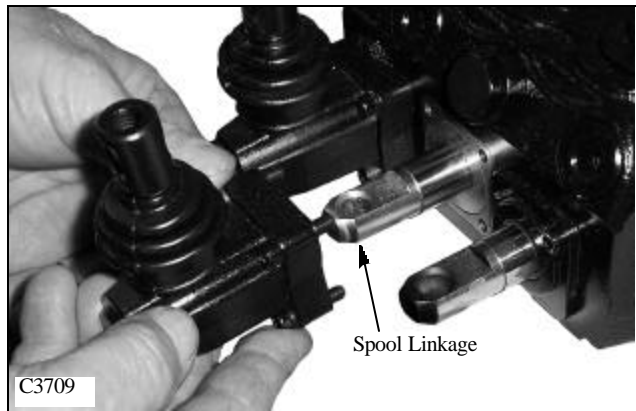
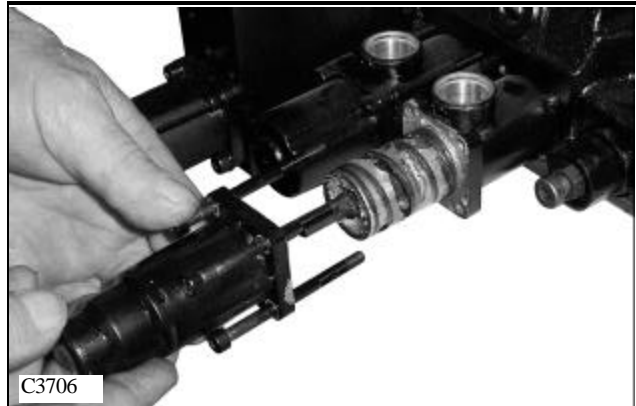

5 Pull out the spool. (fig. C3713) As you pull out the spool, note it's smooth action as it comes out of the valve body. The spool should move freely and smoothly in the bore of the valve body. Check the control valve spool and bore for scuff marks or abnormal wear. Replace the spool and or control valve if signs of wear are present.

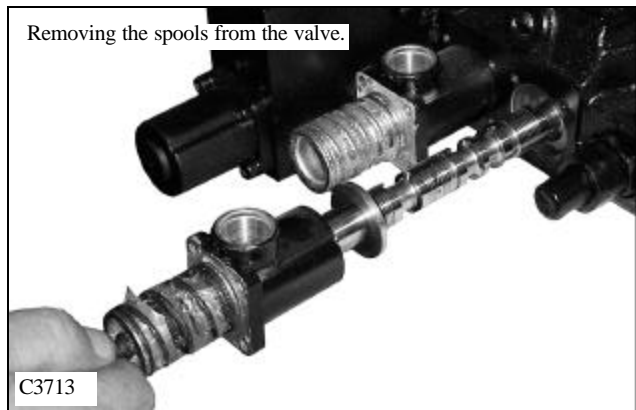

6 Remove the check valves from control valve body. (fig. C3717) They are located between the ports of each section. Check the seat and poppet of the valve body and check valve.

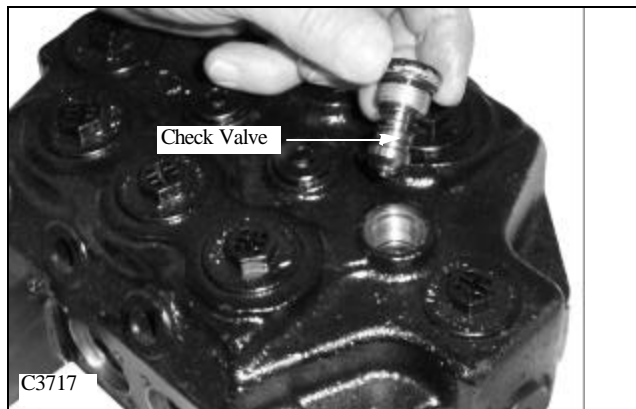

# CONTROL VALVE 1.3

## 1

### Disassembly Repair 137/153 (cont'd)

7 When replacing the spool to the control valve, use new O-ring seals and apply oil to the O-rings and spools. (fig. C3718).

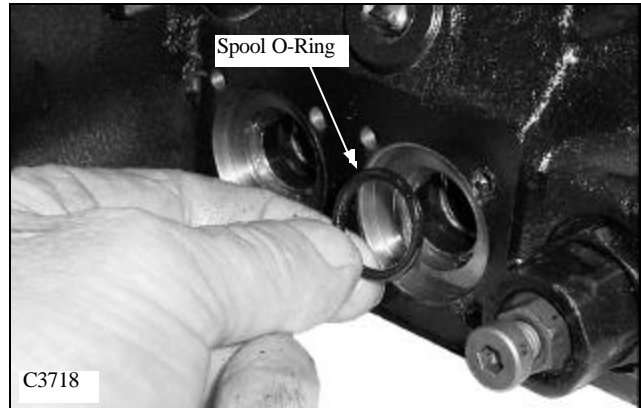

8 Fit the seal washer to the control valve with the beveled side of the washer facing the control valve. (fig. C3719) Fit the spool to the control valve now if repairs are not needed to the detent or spring return mechanism. Use oil to lubricate the spool before inserting to the control valve.



9 Place the cable end of the spool in a vice, or insert a screw driver through the clevis pin holes, to keep it from turning. The detent is threaded to the spool and can be removed for inspection or repairs.(fig. C3724)

Replace broken springs, worn detents and / or damaged detent balls with a new detent kit.

Apply Loctite 542 to the threads of the detent when installing to the spool.

Apply Castrol "Sphero"l" TN grease to the inside of the spring cover.



10 When installing the detent to the control valve spool, apply Loctite type (542) to the threads. Tighten the detent to the spool at 17.7 ft lbs (24 Nm). (fig. C2254)

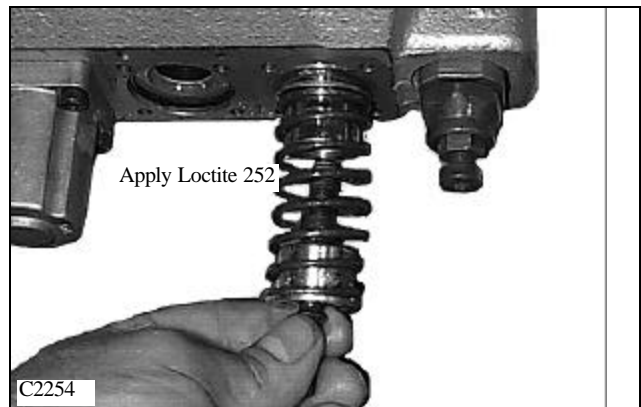

# CONTROL VALVE 1.3

1

## Disassembly / Repair 137/153 (cont'd)

11 Install the spring return / centering cover and tighten the mounting screws evenly to 4.9 ft lbs (6.6 Nm). Install the end cap to the cover and tighten to 7.2 ft lbs (9.8 Nm) . (fig. C2258)

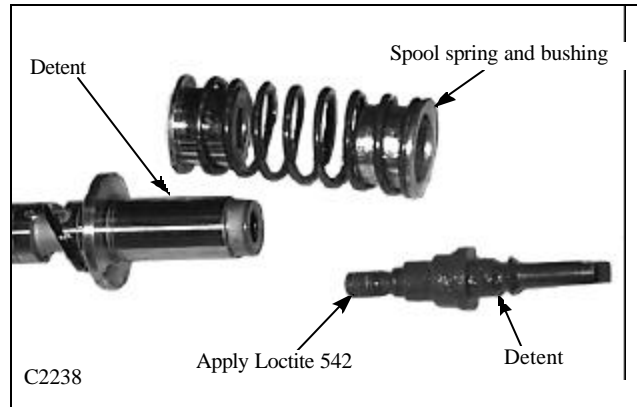

12 Install the spring return / centering cover and tighten the mounting screws evenly to 4.9 ft lbs (6.6 Nm). Install the end cap to the cover and tighten to 7.2 ft lbs (9.8 Nm) . (fig. C2258)

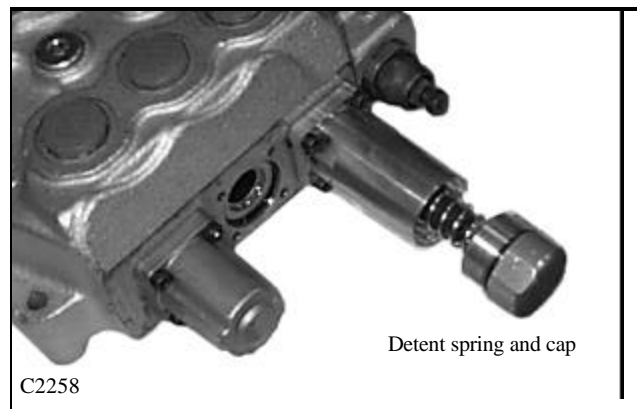

## Solenoid Controlled Auxiliary

1 Remove the screws retaining the solenoid coil. Remove the 12 VDT solenoid coils. (fig. C4238)

2 Inspected the O ring on the solenoid coils for damage. Replace if necessary.

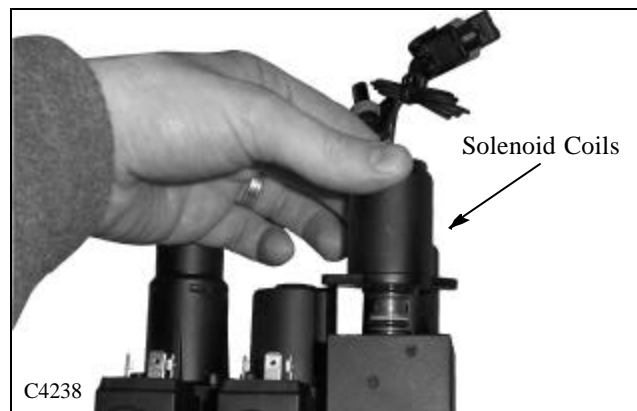

3 Remove the screws retaining the solenoid assembly to the control valve. (fig. C4239). Upon assembly tighten the screws to 4.9 ft lbs (6.6 Nm).

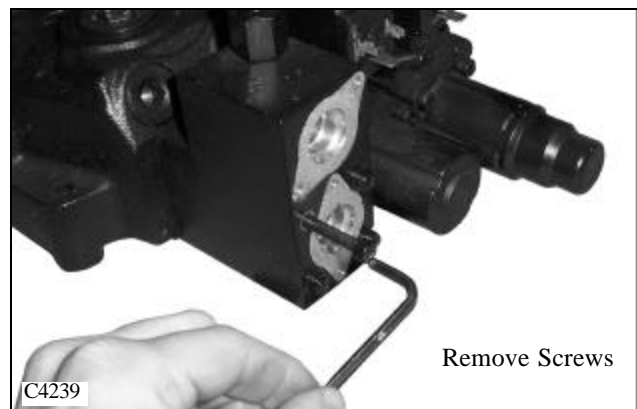

# CONTROL VALVE 1.3

## 1

### Disassembly / Repair 137/153 (cont'd)

4 Remove the solenoid assembly from the control valve. (fig. C4242)

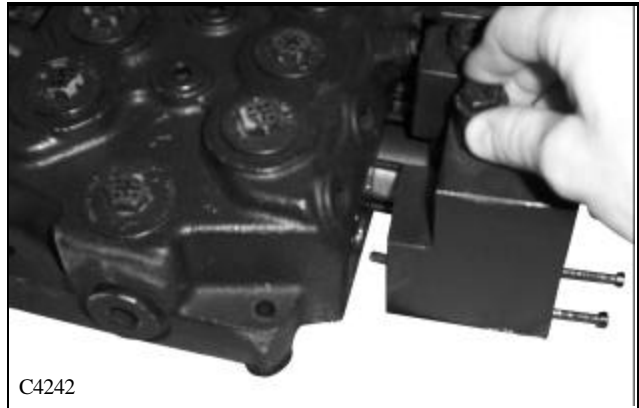

5 Remove the screws and the bottom end cap from auxiliary section.(fig.4243)

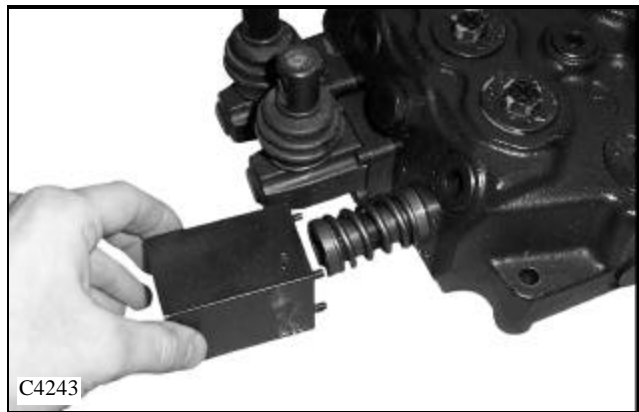

6 Remove the solenoid spool assembly from the control valve. (fig. C4244) Note the effort required to remove the spool from the spool bore. It should come out smoothly without binding or “snagging” throughout it’s travel.



7 Inspect the spool and spool bore for abnormal wear. (fig. C4245) Replace the spool and / or the control valve if large scratches or indentations are present in the spool or spool bore. Minor scratches can be removed from the spool with extra fine emery cloth.

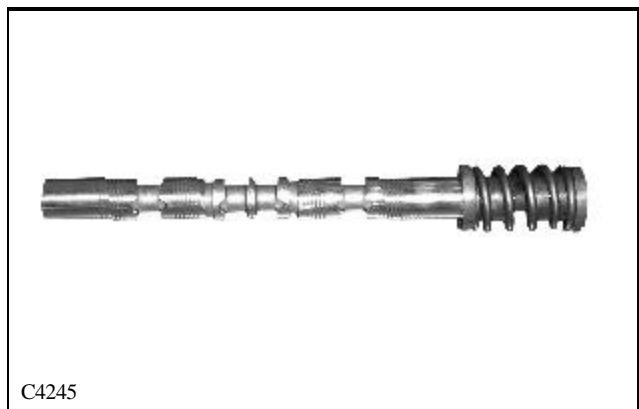



# CONTROL VALVE 1.3

# 1

## Disassembly / Repair 137/153 (cont'd)

8 Hold the spool with a Hex allen wrench while removing retaining screw. (fig. C4246) Remove the spring and spring bushing from the spool assembly. (fig. C4247) When installing the spring assembly to the spool, apply Loctite 542 to the threads and tighten the screw to 17.7 ft lbs (24 Nm).

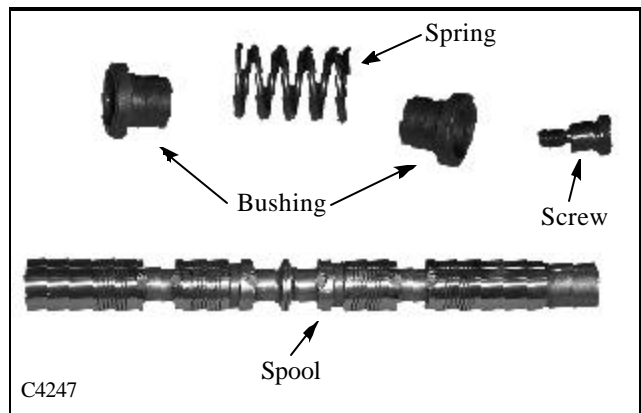
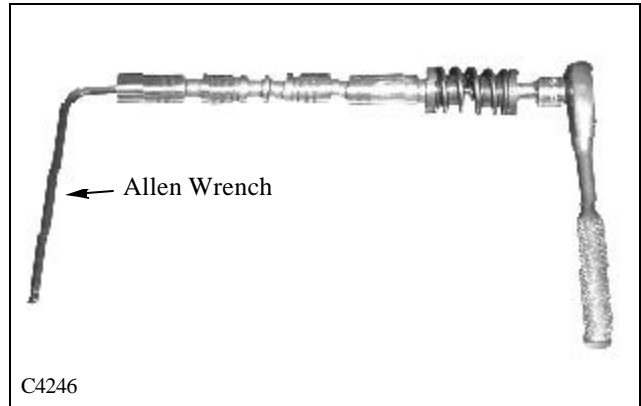

9 Upon assembly, use new O-ring seals. (fig. C4248) Don't overlook the small O-ring seal between the cylinder and valve body. (fig. C4249) Lubricate the spool O-ring seals with system oil. Apply Castrol "Sphero" grease to the inside of the spring covers.

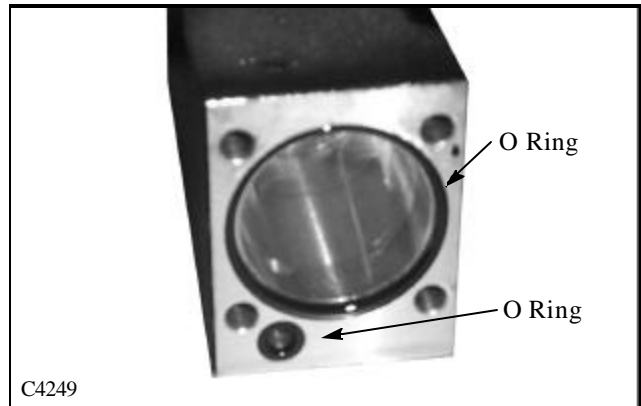
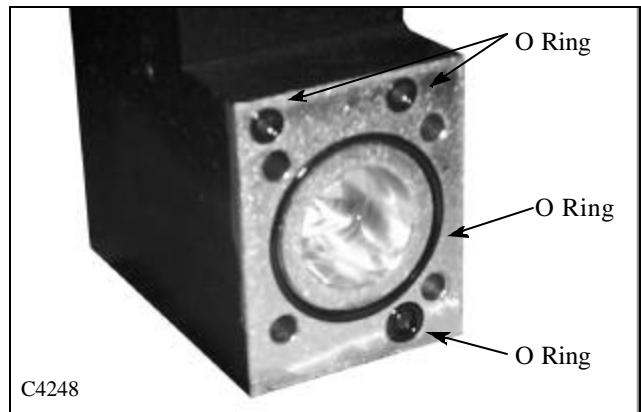

# 1

# CONTROL VALVE 1.3

## 1

### Disassembly / Repair 1300/135

Before disassembling the hydraulic control valve, clean the body with a suitable solvent and dry with compressed air. (fig. C3744)



#### WARNING

To avoid eye injury, use safety goggles when cleaning with compressed air.

Ensure all openings are plugged to prevent solvents and dirt from contaminating the control valve assembly.

1. Remove the pressure relief valve. Discard the O-rings. (fig. C3746)

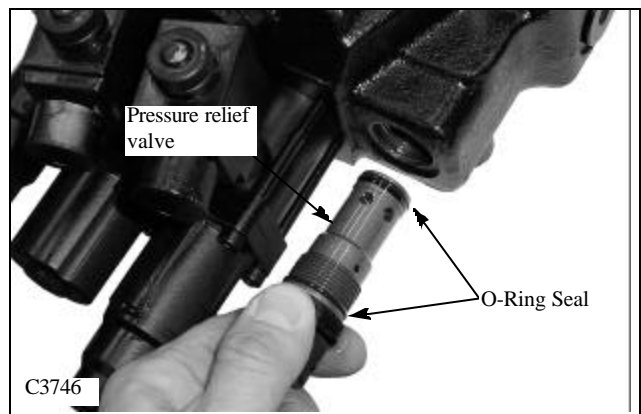

2. Remove the solenoid coils and locking pin from the valve lock block. (fig. C3748) There are 2 O-ring seals located on either side of the solenoid coils.

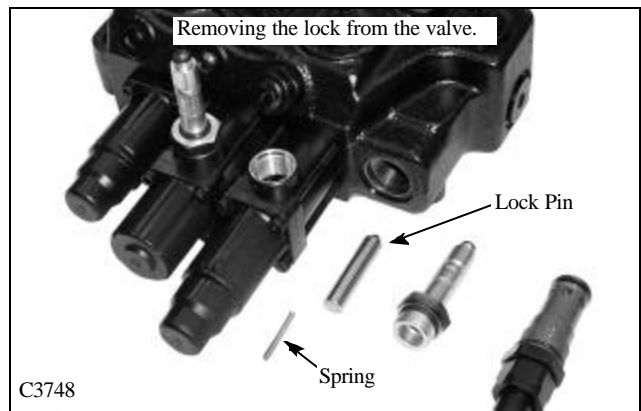

3. Remove the spring return detent kit and spring center cap locks. (fig. C3749)



# CONTROL VALVE 1.3

1

## Disassembly / Repair 1300/135 (con't)

4 Remove the control box from the spool linkage end. The box needs to be tilted up towards the valve to release the hardened ball on the control box pin from the hole in the spool end and pull it away from the valve. (fig. C3752).



5 Pull out the spool. (fig. C3754) As you pull out the spool, note it's smooth action as it comes out of the valve body. The spool should move freely and smoothly in the bore of the valve body. Check the control valve spool and bore for scuff marks or abnormal wear. Replace the spool and or control valve if signs of wear are present.



6 Remove the check valves from the control valve body (fig. C3757). They are located between the ports of each section. Check the seat and poppet of the valve body and check valve. Replace the check valve and/or the control valve if any signs of wear are present.

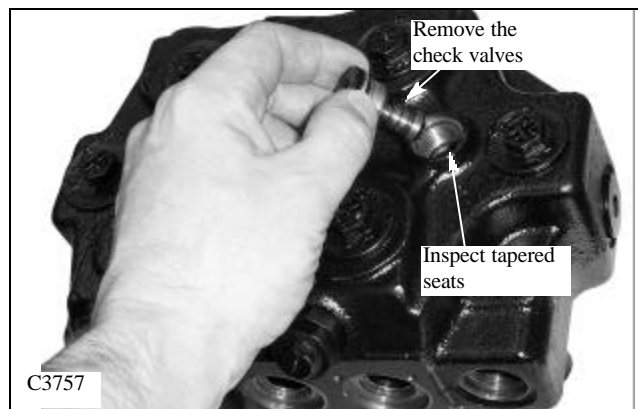

# CONTROL VALVE 1.3

## 1

### Disassembly / Repair 1300/135 (con't)

7 When replacing the spool to the control valve, use new O-ring seals and apply oil to the O-rings and spools. (fig. C3718).

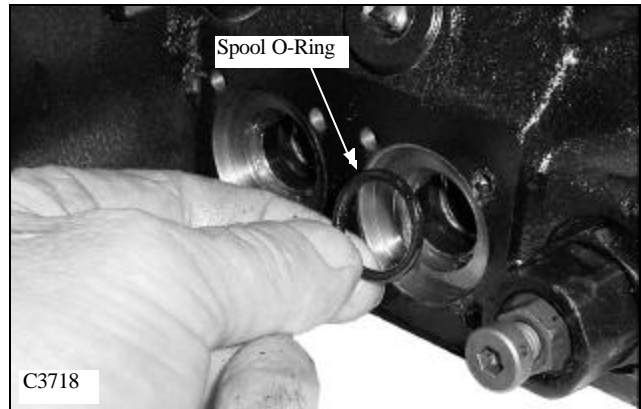

8 Fit the seal washer to the control valve with the beveled side of the washer facing the control valve. (fig. C3719) Fit the spool to the control valve now if repairs are not needed to the detent or spring return mechanism. Use oil to lubricate the spool before inserting to the control valve.

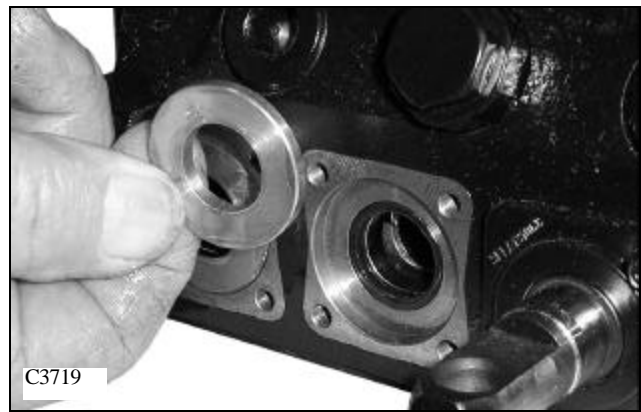

19 Place the cable end of the spool in a vice, or insert a screw driver through the clevis pin holes, to keep it from turning. The detent is threaded to the spool and can be removed for inspection or repairs. (fig. C2238, C2242)

Replace broken springs, worn detents and / or damaged detent balls with a new detent kit.

Apply Loctite 542 to the threads of the detent when installing to the spool.

Apply Castrol "Sphaerol" TN grease to the inside of the spring cover.

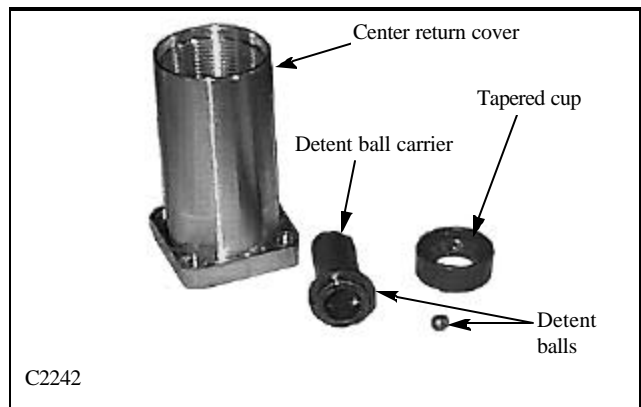
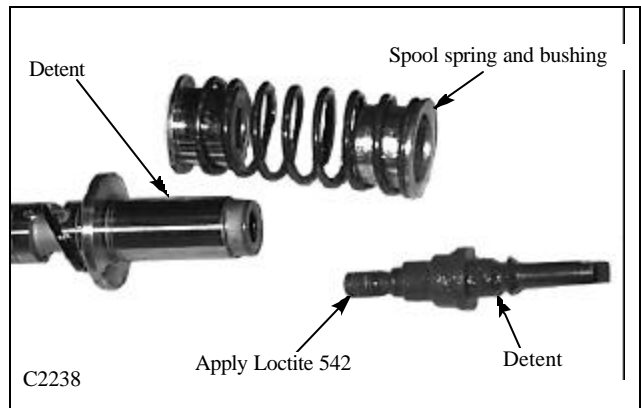

# CONTROL VALVE 1.3

1

## Disassembly / Repair 1300/135 (con't)

10 When installing the detent to the control valve spool, apply Loctite type 542 to the threads. Tighten the detent to the spool at 17.7 ft lbs (24 Nm). (fig. C2254)

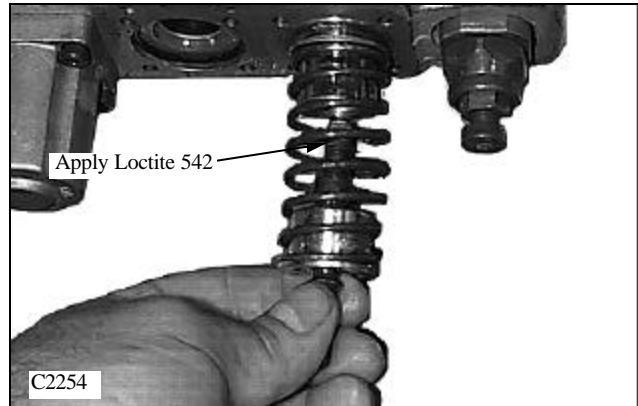

11 Install the spring return / centering cover and tighten the mounting screws evenly to 4.9 ft lbs (6.6 Nm). Install the end cap to the cover and tighten to 7.2 ft lbs (9.8 Nm) (fig. C2258).

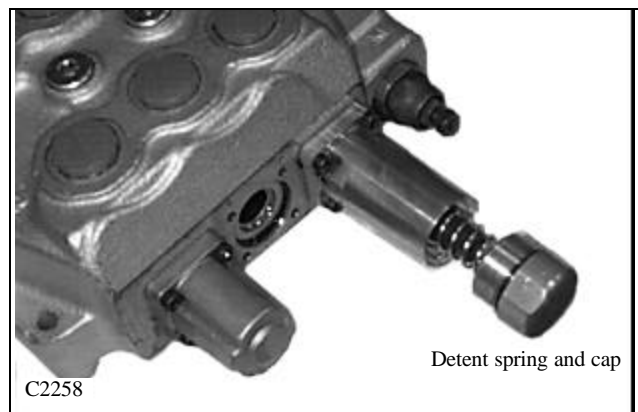

# HYDRAULIC CYLINDERS 1.4

# 1

T 153 Shown

Lift cylinder

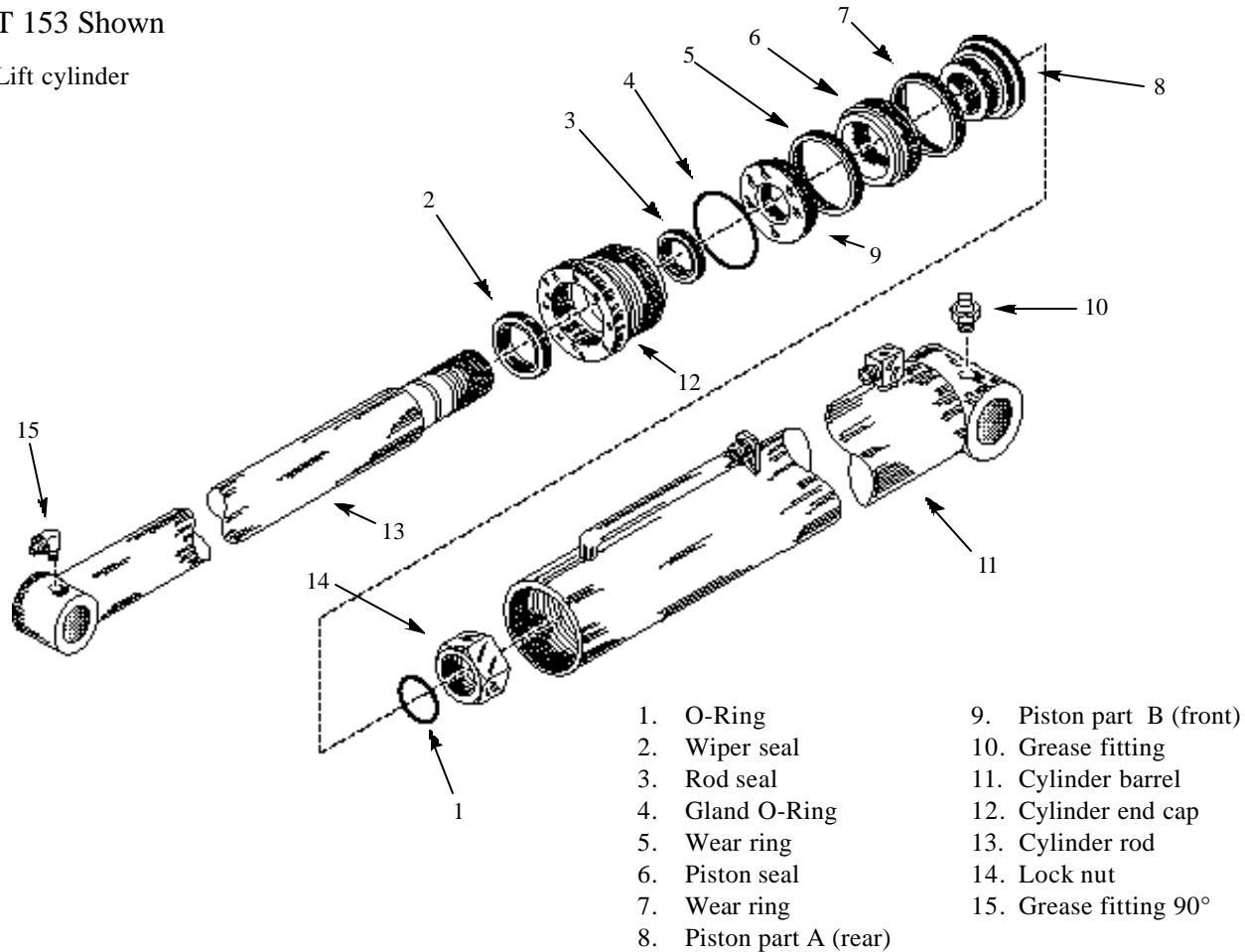

C1179

## General Information

All cylinders are a double acting, designed to extend and retract under pressure.

The piston rods, which are made of high strength distortion free material, are precision ground and hard chrome plated. The cylinder barrels are micro honed to close tolerance, straightness and smooth finish for long piston packing seal life.

All cylinders have a 2 piece piston assembly made of ductile iron and a polypac seal arrangement consisting of a piston seal and 2 wear rings.

The rod seal is a "U" cup design, with the "U" facing the pressurized oil. The rod wiper keeps foreign matter from entering the cylinder by wiping the rod clean as the cylinder retracts.

The gland nut seal is of an "O" - ring design. This seal keeps the oil from leaking around the gland nut and cylinder barrel threads.

Certain cylinders have spacers in them. These spacers are used to limit the stroke of the rod.

Some cylinders also have replaceable hardened bushing in the pivot areas that can be serviced when worn out.

# HYDRAULIC CYLINDERS 1.4

1

## Testing the Piston Seals

Before performing this test, ensure the control linkages are not binding and the hydraulic control valve spools are centering in the neutral position. Check the hydraulic circuit for external leaks. These conditions will give the same symptoms as a worn piston seal. If the cylinders under pressure are sluggish or stop functioning, these would indicate that oil is leaking by the cylinder piston seal. The following test can be performed to check the cylinder piston seal.

### IMPORTANT

**Allowable boom or bucket cylinder drop: 1.5" in 3 minutes, @ loaded rating and operating temperature.**



### WARNING

**Use extreme caution when checking the hydraulic system for leaks. Fluid under pressure can penetrate the skin and cause serious injury.**

1. Retract the cylinder(s) to be tested. Shut off the engine and cycle the controls to release the hydraulic pressure. Have a container ready to catch any waste oil to prevent environmental contamination.
2. Disconnect the hoses from the cylinder to be tested. Cap the hose with a plug to prevent contamination.
3. Disconnect the cylinder to be tested as outline on page 1-38 or 1-39.
4. Place the base or fixed end of the cylinder in a vice or support to hold the cylinder.
5. Extend the cylinder ram about 6 ~ 8". Fill the fixed end cylinder port with hydraulic oil using a funnel.
6. Cap both ports with a 3/4 JIC steel cap to prevent system pressure from escaping.
7. Apply pressure using your hand to the ram.
6. Monitor the movement of the ram. If the ram slowly retract back to it original position, then the seals are bad and need replacement. If the cylinder stays extended then you may need to check the load check valves or spool wear in the hydraulic control valve.
7. Repeat for all both pairs of cylinders.
8. If the cylinder passed the piston seal test then assemble the cylinder to the loader.

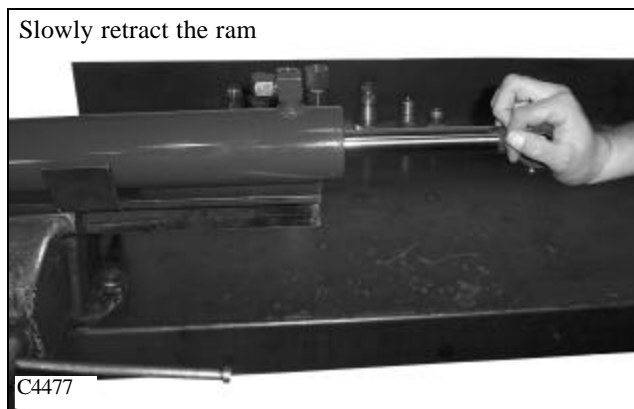
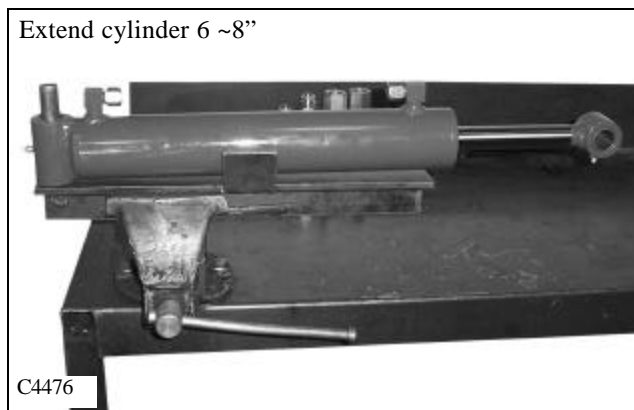
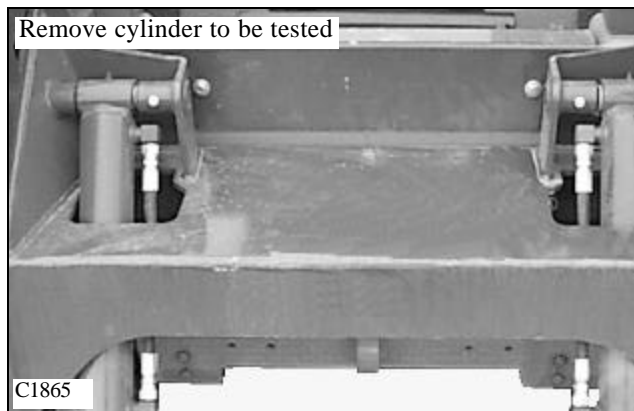
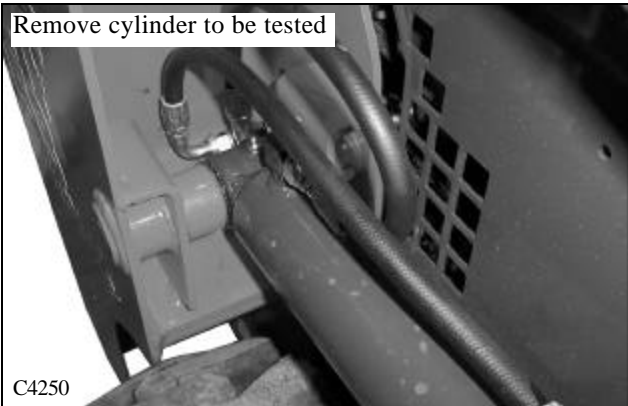

# HYDRAULIC CYLINDERS 1.4

## 1

### Lift Cylinder Replacement



#### WARNING

To prevent personal injury never repair or tighten hydraulic hoses while the engine is operating or the system is under pressure.

The following procedure will assist you in cylinder removal.

For removal of the boom cylinders:

#### IMPORTANT

Cap all open lines and ports to prevent contamination.

- 1 Lower the boom arms, stop the engine and cycle the controls to relieve any hydraulic back pressure in the system. Lock the control in the float or detent position.
- 2 Remove the hydraulic hoses from the cylinder. (fig. C4251) Cap all open ports and lines to prevent contamination.
- 3 Remove the lock nut and bolt from both mounting pins. (fig. C4250)
- 4 Remove the front pivot pin by pushing the pin out from behind the boom arm, out toward you. (fig. C3647) With an appropriate punch and hammer to prevent brooming of the pin, remove the rear pin. (fig. C4253) Brooming the pin makes it difficult to remove.
- 5 Remove the cylinder from the loader.
- 6 Upon replacement, inspect the pivot pins and cylinder bushing for any wear. Replace if necessary. Reverse order above for installation.
- 7 Upon start up, check for system leaks and replenish the hydraulic reservoir as required.



#### WARNING

Use extreme caution when checking the hydraulic system for leaks. Fluid under pressure can penetrate the skin and cause serious injury.

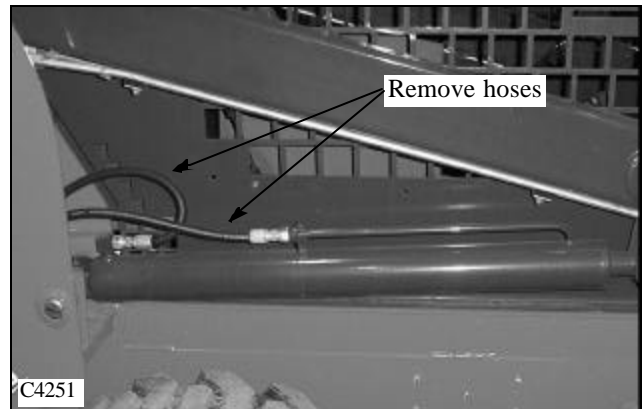

C4251

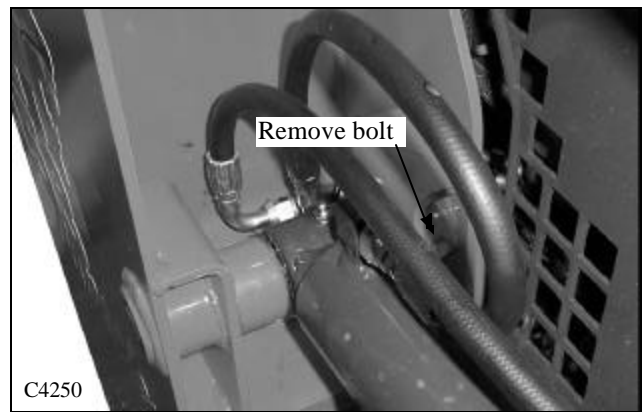

C4250

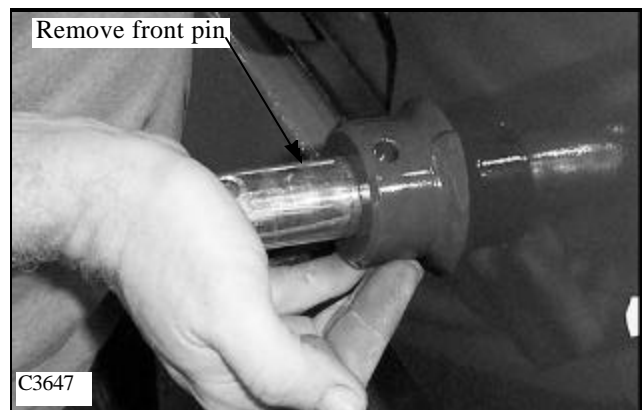

C3647



C4253



# HYDRAULIC CYLINDERS 1.4

1

## Tilt cylinder Replacement

For tilt cylinder removal:

- 1 Lower the boom arms, remove any attachment and extend the tilt cylinders. Shut off the engine and cycle the controls to relieve excessive back pressure in the hydraulic system.(fig. C3649)
- 2 Loosen or remove the hydraulic hoses from hydraulic tubing under the boom arm step if you are changing the hoses also. (fig. C3441)
- 3 Remove the hydraulic hoses from the tilt cylinder. Plug and or cap all open ports or lines to prevent contamination. (fig. C3439)
- 4 Remove the lock nuts from the bolts retaining the pivot pins to the loader and remove the bolts. (fig. C3649)
- 5 Remove the pivot pins by tapping out with a brass drift pin. (fig. C4252)
- 6 Remove the cylinder from the loader.
- 7 Upon reassembly, inspect the pivot pins and bushing for wear and replace as required. Reverse order for cylinder installation.
- 8 Upon start up, check for system leaks and replenish the hydraulic oil reservoir as required.

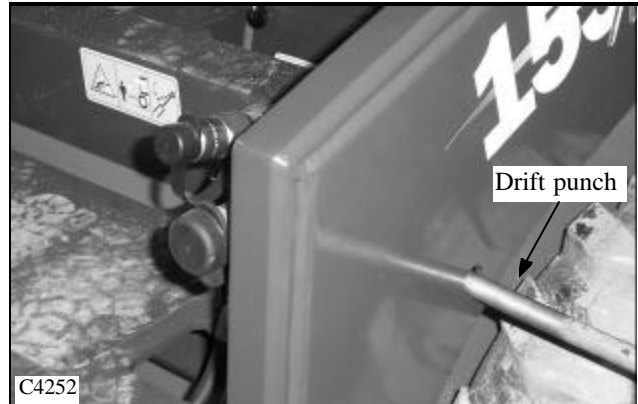
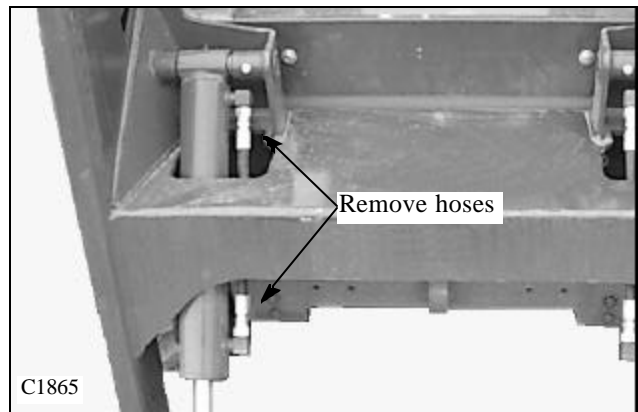
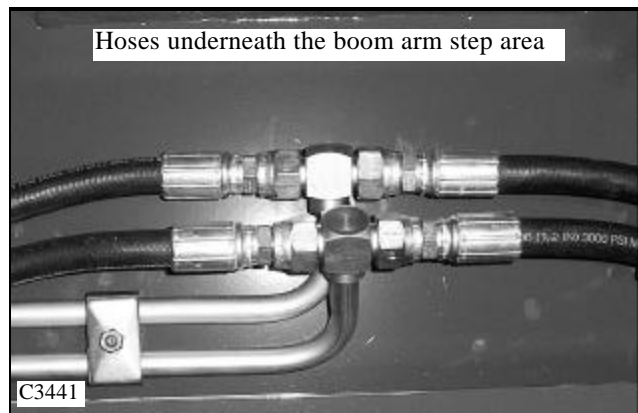
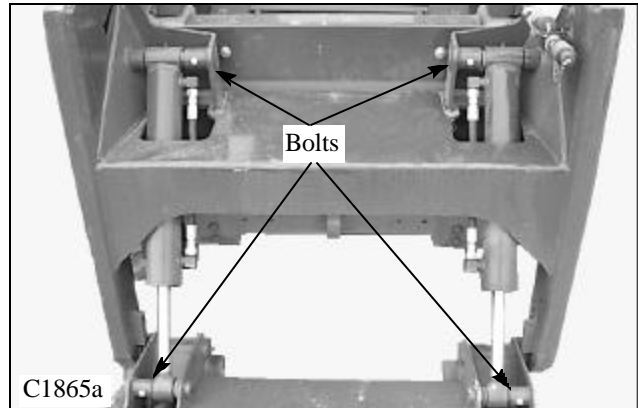

 **WARNING**

Use extreme caution when checking the hydraulic system for leaks. Fluid under pressure can penetrate the skin and cause serious injury. Never tighten or repair hydraulic lines while the engine is operating.

# HYDRAULIC CYLINDERS 1.4

## 1

### Cylinder Disassembly

Before Attempting repairs to the hydraulic cylinder, clean the body with a suitable solvent. Ensure all openings are plugged to prevent solvent from entering the cylinder.

- 1 Remove the cylinder as outlined previously.
- 2 Place the base end of the cylinder in a vise or on a pin held in the vise and support the front end of the body. Remove the plugs from the hose ports. (fig. C3725)
- 3 Loosen the gland nut from the cylinder barrel using a spanner wrench. The gland nut threads are coated with loctite bonding agent at time of assembly. It may be necessary to apply heat to the gland nut and cylinder barrel threaded area, with a torch, to ease removal. (fig. C3725)
- 4 Remove the gland nut, rod and piston seal assembly from the barrel. (fig. C3726)

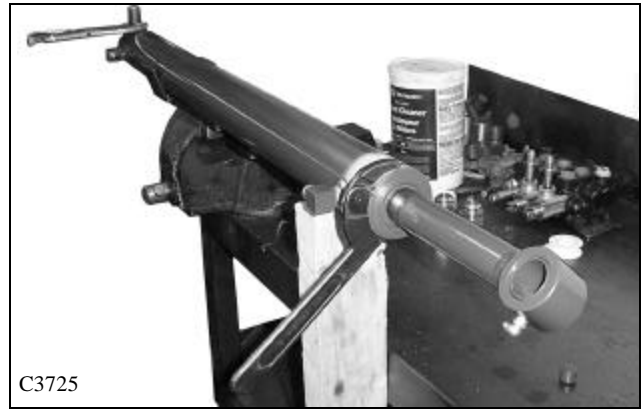

C3725



C3726

- 5 Place the cylinder rod bushing end in a vise or on a pin held in a vise and remove the lock nut from the rod. (fig. C3729)

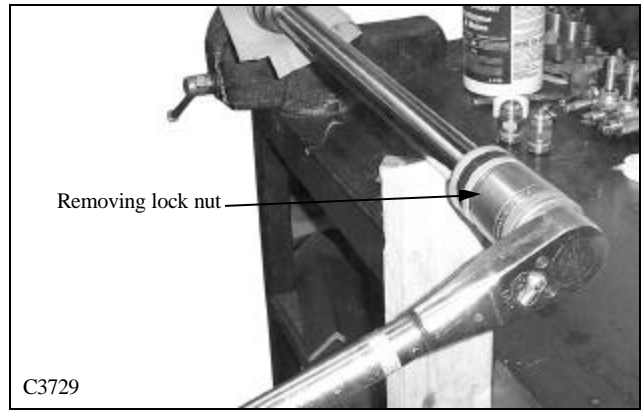

C3729

- 6 Remove the 2 piece piston assembly from the rod. (fig. C3731)
- 7 NOTE: Some piston assemblies rear piston parts are threaded onto the rod. You will need to use a spanner wrench to remove this type of rear piston.



C3731

# HYDRAULIC CYLINDERS 1.4

8 Depending on the design of the rear piston, non threaded type, remove and discard the o-ring seal from the end of the cylinder rod. (fig. C3732)

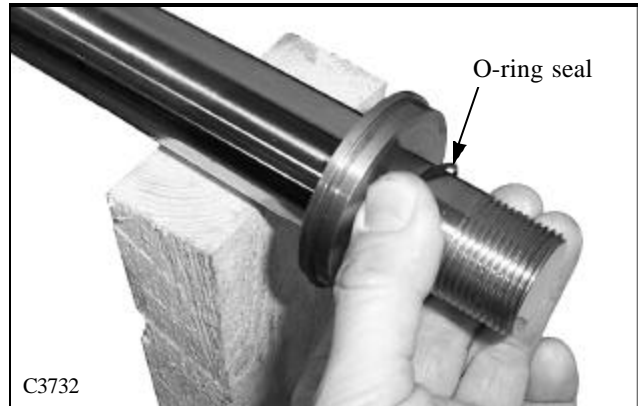

9 Remove the gland nut assembly from the cylinder rod. (fig. C3733)

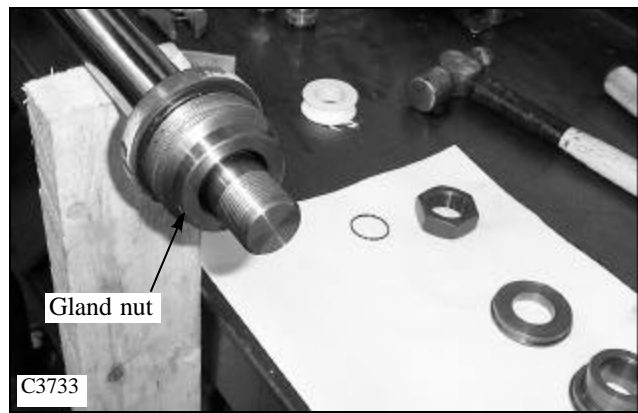

10 Remove and discard the wiper seal, rod seal and o-ring seals and teflon back up washer, (if used), from the gland nut assembly. (fig. C3734) NOTE: Some seal designs may vary from illustration

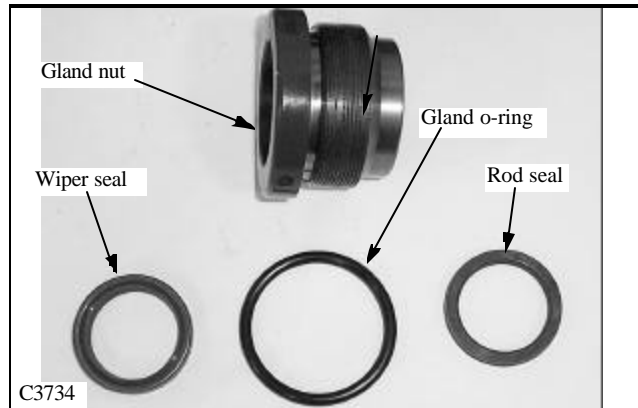

11 Remove and discard the wear rings and piston seal from the piston assembly. (fig. C3735)

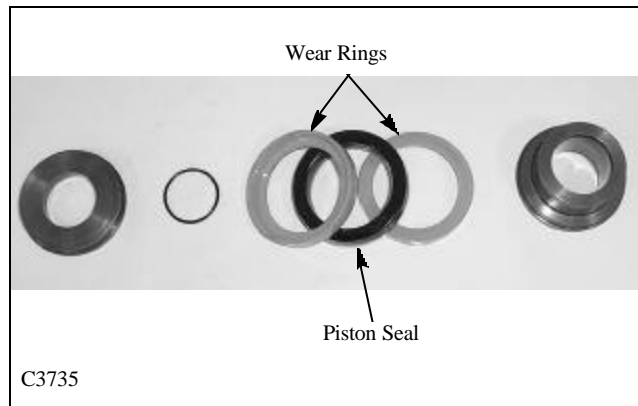

# HYDRAULIC CYLINDERS 1.4

## 1

### Cylinder Inspection

1 Inspect the cylinder rod for scratches, dents and other damage. Minor rod damage may be repaired using a fine abrasive. Major scratches or dents are not repairable and the rod must be replaced. The chrome surface must be intact to provide a rust resistant surface. Blemishes on the rod will damage the rod seal and wiper and will cause leaking after a short period of use.

2 Inspect the cylinder rod threads. The threads must be in good condition to withstand the high torque required to secure the piston assembly to the rod.

3 Inspect the gland nut for nicks, burrs or other damage. Minor damage may be repaired using a fine abrasive.

Smooth down edges that could damage seals and cause leakage.

4 Inspect the gland nut threads for damage.

5 Inspect the piston assembly for damage. Remove minor scratches or damage with a fine abrasive.

6 Using a suitable light, inspect the cylinder barrel bore for scratches, dents, burrs or any other damage. Replace the cylinder barrel if there is any evidence of damage.

7 Inspect the cylinder barrel threads for damage. The threads must be in good condition to withstand the high torque required to secure the gland nut assembly to the cylinder barrel.

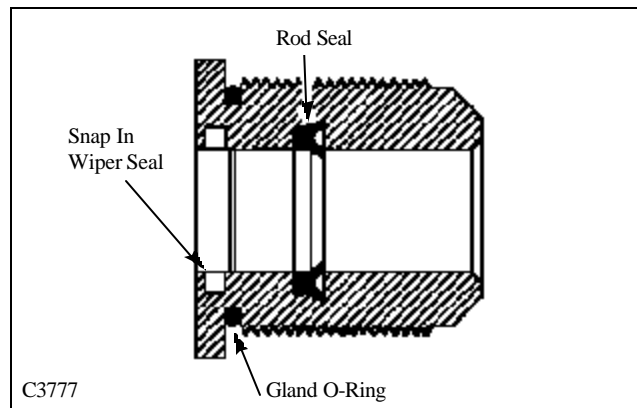
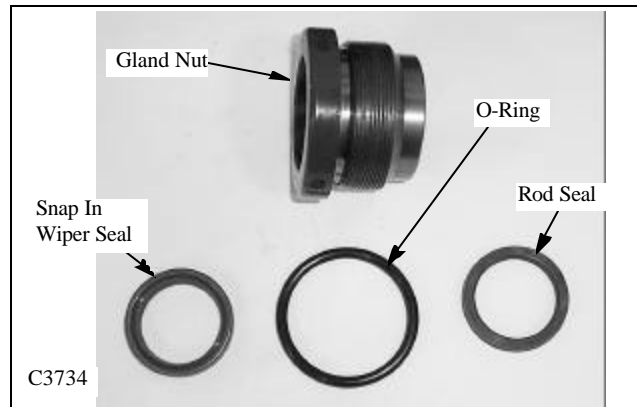

### Cylinder Assembly

1 Install a new gland nut rod seal. Form the seal into an oval shape and place it into the gland nut, with the “U” side of the seal facing the barrel end, and slip the seal into the groove. (fig. C3734,C3777)

2 Install a new wiper seal in the gland nut. (fig. C3734, C3777)

3 Install a new gland nut o-ring seal. (fig. C3734, C3777)

4 Apply system oil to the cylinder rod and assemble the gland nut assembly to the rod. (fig. C3736)



# HYDRAULIC CYLINDERS 1.4

1

5 Install a new o-ring seal on the cylinder rod (if used). Some cylinder rods are fully threaded to accommodate a threaded type rear piston part. (fig. C3737)

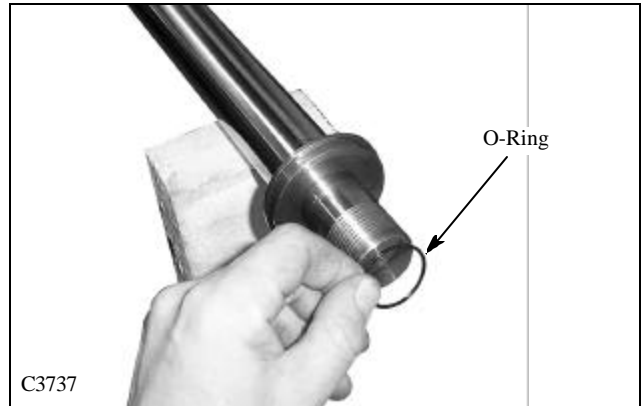

6 Install new wear rings and piston seal to the the 2 piece piston assembly. (fig. C3738)

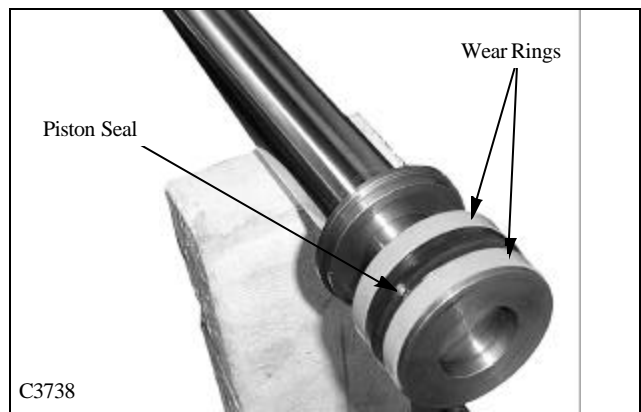

7 Install the piston assembly to the cylinder rod. Some rear piston assemblies are threaded onto the cylinder rod. Use a spanner wrench to install the rear piston part to the cylinder rod. Torque the lock nut to the rod at 250-275 ft lbs (339-373 N.m.). (fig. C3740)

8 Make sure the inside bore of the cylinder barrel is clean. Lubricate the inside of the barrel with system oil. Do not get oil into the threaded area of the barrel.

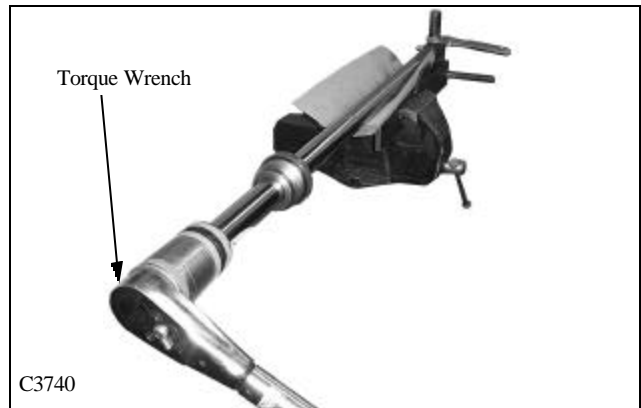

9 Lubricate the piston seal assembly with system oil and install the cylinder rod and piston assembly to the cylinder barrel. (fig. C3741)

10 Apply loctite 242 to the gland nut threads and tighten the gland nut using a spanner wrench. Tighten the gland nut as much as you can using the spanner wrench. Make sure the threaded area of the gland nut and cylinder barrel are free of oil before applying the loctite bonding adhesive.

11 Test the cylinder as outlined in page 1-37. If the cylinder passes the piston seal test then, assemble the cylinder to the loader.



# HYDRAULIC OIL FILTER 1.5

## 1

### General Information

The hydraulic oil filter is located in the engine compartment, accessed by opening the rear door and lifting the engine compartment cover. The filter is mounted on the right side, on the fuel reservoir. All oil returning from the control valve is cooled and then filtered before being used up by the hydraulic system. The hydraulic oil filter is a spin on type with a 5 micron rating. The filter material is a synthetic media which features an accordion pleated design to provide maximum filtration area. Only Thomas approved filters should be used.

The filter mounting head has a built in bypass valve that diverts oil around the filter when more than 25 psi (34 nm) differential pressure is required to force oil through the filter.



### Filter Replacement

The hydraulic oil filter must be changed after the first 50 hours of operation and every 150 hours thereafter.



#### WARNING

**Never repair or tighten hydraulic lines while the engine is operating or the system is under pressure.**

- 1 Lower the boom arms, shut off the engine and engage the parking brake.
  - 2 Open the rear door and raise the engine compartment cover to gain access to the hydraulic filter. (fig. C4223, C1472)
  - 3 Clean the area of excess dirt if necessary to prevent contaminating the new filter when installing
  - 4 Remove the hydraulic oil filter using a proper sized filter wrench. Check to make sure the o-ring seal has come off with the used filter. (fig. C1968)
  - 5 Lubricate the new filter seal with clean system oil.
  - 6 Install the filter and fit hand tight.
  - 7 After start up, check the system for oil leaks.
- Replenish the oil reservoir as required with API 10W30 class SJ. (fig. C3431, C1108)

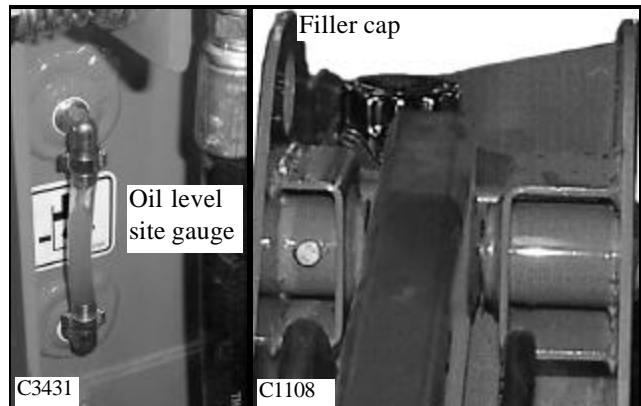
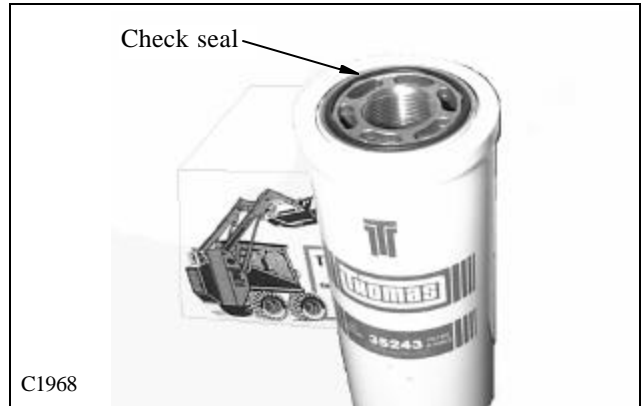

# HYDRAULIC OIL COOLER 1.6

1

## General Information

The hydraulic oil cooler is mounted to the inside of the rear door. (fig. C4255) Oil returning from the control valve is circulated through the oil cooler before being sent on to other parts of the hydraulic system. An engine driven cooling fan drives air through the oil cooler when the rear door is closed.



### WARNING

To avoid eye injury, always use safety goggles when cleaning with compressed air.

The oil cooler should be checked daily for dirt build up on the cooling fins. If air flow is restricted through the cooling fins, over heating of the hydraulic system may occur. Clean any dirt build up with compressed air. Flush with water if necessary. The oil cooler is surrounded by a shroud. The outer edge of the shroud holds a layer of sealing foam that presses against the engine radiator when the rear door is closed. This directs the air, driven by the engine cooling fan (C1872), through the hydraulic oil cooler. The sealing foam and adjustment should be checked at every service interval. The shroud seal (C1873) to radiator adjustment can be made by loosening the upper radiator mounting brace and moving the radiator back or forward. (fig. C1880) If necessary the whole engine may need to be moved if adjustment cannot be made by moving the radiator.

## Cooler Replacement

- 1 Lower the boom arms, engage the parking brake and shut off the engine.
- 2 Open the rear door and remove the cooler shroud.
- 3 Connect a vacuum system to the oil reservoir filler spout, if available, or drain the hydraulic oil reservoir. Be prepared to contain 56 liters of fluid (14.8 gal). Use clean containers if the oil is to be reused.
- 4 Remove the cooler hoses. Plug the open hoses and cooler ports to prevent contamination.
- 5 Remove the cooler from the rear door.
- 6 Remove the fittings from the oil cooler.
- 7 Inspect the fitting o-rings for damage and replace if necessary.
- 8 Install the fittings into the new or repaired oil cooler following the torque chart on section 1.10. Be sure to support the cooler as the fittings are tightened to prevent damaging the cooler.
- 9 Replace the cooler, cooler lines and cooler shroud. Follow the torque chart on section 1.10 when tightening the hydraulic hoses.

- 10 Replenish the hydraulic fluid as required. Check for system leaks and check the fit of the shroud seal to the engine radiator. Adjust if necessary.

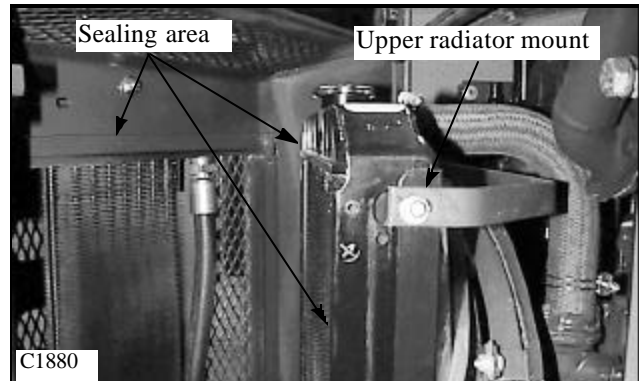
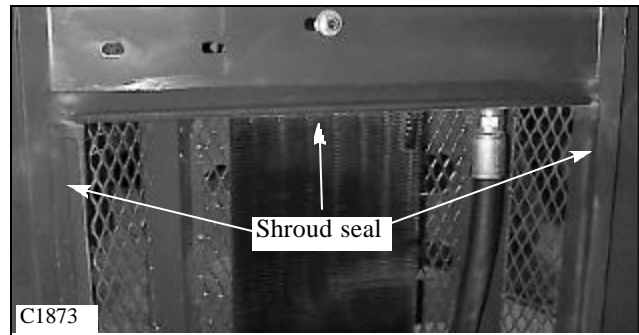
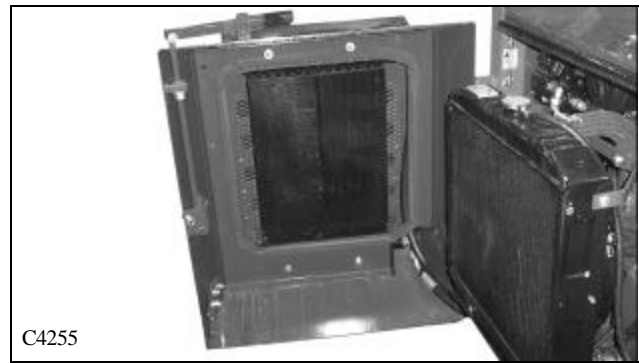

# HYDRAULIC OIL RESERVOIR 1.7

## 1

### General Information

The hydraulic oil reservoir is located at the rear of the loader on the left hand side. (fig. C4214) The reservoir is completely separated from all chain and gear drives to eliminate contamination. A magnetic drain plug is installed in the bottom of the reservoir, and a magnet is attached to the 100 micron suction filter, to assist in removing metal particles from the oil.

Oil level is checked through a sight gauge located just inside the engine compartment, left hand side, on the oil reservoir. The proper fill level is marked by a line and should be checked daily. (fig. C1878)

The oil reservoir fill cap is located at the top of the reservoir. (fig. C1879) The oil fill cap assembly has a 30 micron screen to catch larger particles of contaminant before entering the reservoir, but **always use oil filtered through a 5 micron min. filter for replenishing the hydraulic reservoir.** The oil fill cap is also a reservoir vent, or breather, and contains a 10 micron filter to remove air borne particles.

### Checking The Oil Level

- 1 Check the reservoir oil level with the loader on level ground.
- 2 Lower the boom arms, retract the cylinders and engage the parking brake. Shut off the engine.
- 3 Open the rear door. (fig. C4223)
- 4 Check the oil level in the sight gauge. (fig. C1878)
- 5 If oil is visible approximately mid way in the sight gauge, the level is correct. The correct level is marked with a line from the factory.

### Adding Oil

- 1 Remove the bolt, or lock, on the reservoir filler cap.
- 2 Open the filler cap. (fig. C1879)
- 3 Inspect the filler screen in the filler neck for damage. If the filler screen is damaged, replace it.
- 4 Using a clean container, add 10W30 API class SJ.
- 5 Replace the filler cap and replace the bolt, or padlock, in the cap to prevent vandalism.

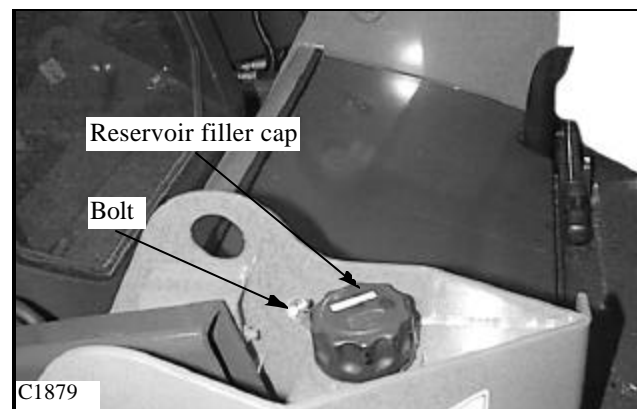
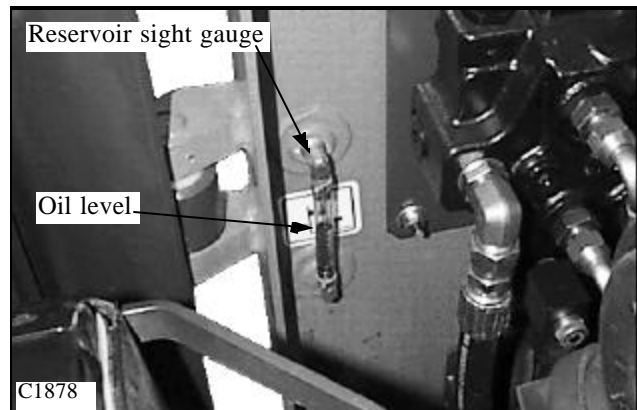
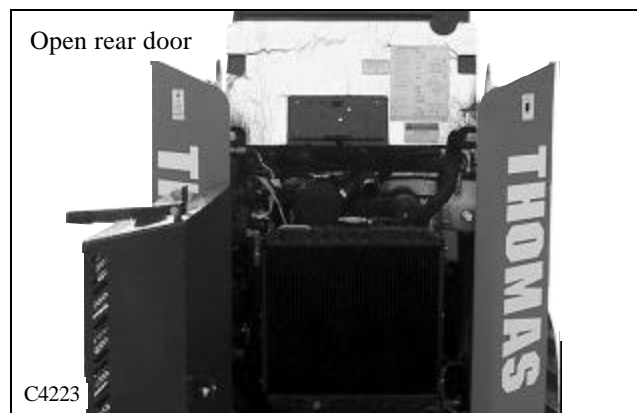
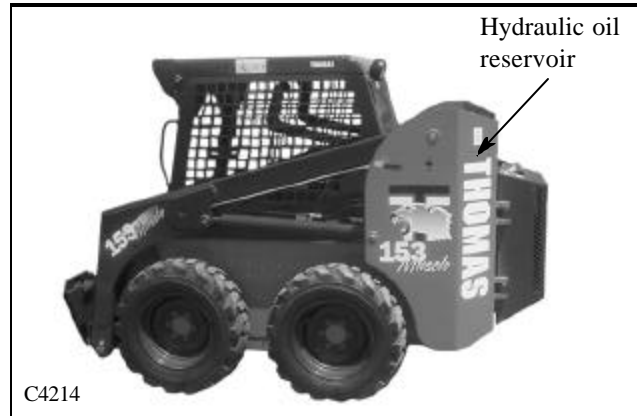



# HYDRAULIC OIL RESERVOIR 1.7

1

## Servicing The Oil Reservoir

Change the hydraulic oil, change the suction screen element and clean the magnet in the tank after every 1000 operating hours or if the oil has become contaminated or after any major hydrostatic drive system repair.

- 1 Lower the boom arms, shut off the engine and engage the parking brake.
- 2 Remove the magnetic drain plug located at the bottom of the hydraulic oil reservoir. Clean any metal particles that may be attached to the magnet. (fig. C4446) Have containers ready to hold approximately 8 gallons (30 liters) of fluid. Replace the drain plug using teflon sealing tape or liquid type sealant on the plug threads.
- 3 Access the suction screen element in the hydraulic reservoir by removing the inspection cover on the reservoir, located in the engine compartment. (fig. C1871) Clean the excess silicone from the cover and reservoir.

NOTE: You may need to remove the control cables and hydraulic hoses to gain access to the inspection cover nuts.

- 4 Remove the suction screen element from the reservoir by turning counter clockwise. (fig. C3663, C3664)
- 5 Remove and clean the magnet attached to the suction element. (fig. C3663)
- 6 Install the magnet onto a new suction element and install the suction element.
- 7 Seal the inspection hole and install the inspection cover to the reservoir. Do not over tighten the mounting nuts. Maximum torque is 15 ft lbs (20.3 N.m.).
- 8 Fill the reservoir to the proper level with 10W30 API classification SJ oil, approximately 8 gallons or 30 liters.

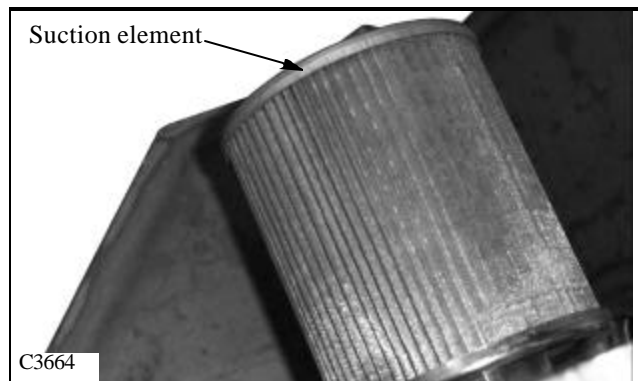
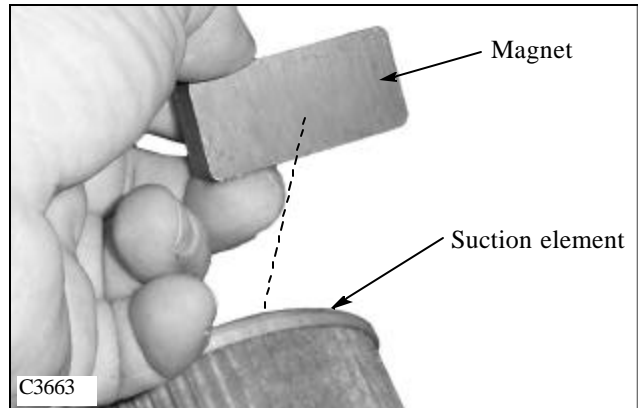
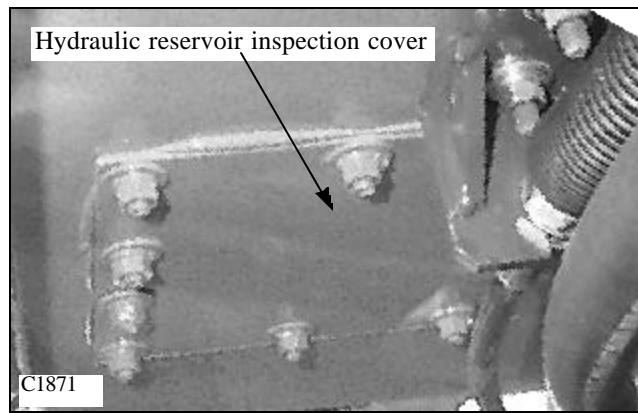

# TROUBLE SHOOTING 1.8

# 1

Problem	Cause	Corrective Action	Section
Loss of hydraulic power (no flow from the gear pump).	Reservoir low on oil.	Check for leaks. Fill the reservoir to the proper level.	1.8
	Universal joint between engine and tandem pump failure.	Inspect and replace the damaged parts as required. Check for proper alignment.	7.11
	Gear pump not functioning.	Inspect and replace damaged parts.	1.4 / 2.9
	Splined coupling failure in the hydrostatic pump	See the Sauer Sundstrand Repair Manual BLN 9992.	2.10
Loss of hydraulic power (full flow from gear pump).	Electrical failure.	Check fuse, switches and wiring.	8
	Auxiliary hydraulics engaged.	Disengage the switch.	4.9
	Relief valve failure or out of adjustment.	Check pressure. Adjust or repair as required.	1.4
	Control locks engaged	Check fuse, safety switches and valve lock parts.	1.4 / 8
Hydraulic action jerky.	Reservoir low on oil.	Check for leaks. Fill the reservoir to the proper level.	1.8
	Control linkages loose or worn.	Inspect, adjust or replace parts.	4
	Air in hydraulic system.	Check for leaks between the oil reservoir and pump.	
	Load check valve not functioning.	Inspect and replace damaged parts.	1.4
	Control valve spool spring return mechanism not functioning	Inspect and replace damaged parts.	1.4
Boom raises slowly at full rpm	Reservoir low on oil.	Check for leaks. Fill the reservoir to the proper level.	1.8
	Control linkages loose or worn.	Inspect, adjust or replace parts.	4
	Auxiliary hydraulics engaged.	Disengage the switch.	4.9
	Lifting more than rated capacity.	Reduce the load.	
	Engine rpm too low.	Check engine rpm and reset.	7.11
	Relief valve failure or out of adjustment.	Check pressure. Adjust or repair as required.	1.4
	Cylinder seal(s) failure.	Check seals.	1.5
	Internal leakage in the control valve.	Inspect the control valve and repair as required.	1.4
Hydraulic cylinders will not support a load. (leak down)	Control valve spools not centering.	Check control linkage and control valve spool spring centering devise.	1.4 / 4
	External leak between control valve and cylinders	Inspect and repair.	
	Cylinder seal(s) failure	Check seals.	1.5
	Load check valve not functioning.	Inspect and replace damaged parts.	1.4

# TROUBLE SHOOTING 1.8

1

Problem	Cause	Corrective Action	Section
Hydraulic oil overheating.	Reservoir low on oil.	Check for leaks and replenish as required.	1.8
	Oil cooler plugged or dirty.	Clean the cooling fins.	1.7
	Auxiliary hydraulics engaged.	Disengage.	4.9
	Cooling fan damaged or inoperative	Check fan and drive belt	1.7
	Engine rpm too low.	Check engine rpm and reset.	7.11
	Temperature sender defective.	Replace.	8
	Relief valve failure or out of adjustment.	Check pressure, adjust or replace.	1.4
	Wrong type of hydraulic fluid.	Replace.	1.8

## TORQUE CHART 1.9

**Torque Chart** NOTE: all torques are in ft lbs. (Multiply by 1.36 = Nm)

HOSE SIZE	37° JIC FITTINGS	HOSE SIZE	ORB FITTINGS
1/4	9 to 10	1/4	14 to 16
5/16	15 to 16	5/16	18 to 20
3/8	20 to 22	3/8	24 to 26
1/2	30 to 33	1/2	50 to 60
5/8	40 to 44	5/8	72 to 80
3/4	70 to 77	3/4	125 to 135
7/8	82 to 90	7/8	160 to 180
1	55 to 60	1	200 to 220
1 1/4	120 to 132	1 1/4	210 to 280
1 1/2	131 to 144	1 1/2	270 to 360
2	300 to 330		

The following torque specifications are for steel ORB fittings into aluminum.

HOSE SIZE	ORB FITTINGS	HOSE SIZE	ORB FITTINGS
1/4	5 to 7	3/4	40 to 45
5/16	8 to 10	7/8	50 to 55
3/8	10 to 12	1	90 to 99
1/2	21 to 24	1 1/4	80to 90
5/8	27 to 30		

# 1

## CONVERSION CHART 1.10

### CONVERSION FACTORS

#### U.S. To Metric

	MULTIPLY	BY	TO OBTAIN
Area:	sq. foot	0.092 903	square meter
Force:	pound force	4.448 222	Newton
Length:	inch	25.4	millimeter
	foot	0.304 8	meter
	mile	1.609 344	kilometer
Mass:	pound	0.453 592	kilogram
	ounce	28.35	gram
Mass/Energy:	lb/hp-hr	608.277 4	g/kW-hr
Mass/Volume:	lb/cubic ft.	16.0185	kg/cubic meter
Power:	horsepower	0.745 700	kilowatt
Pressure:	lbs/sq.in.	6.894 757	kilopascal
	lbs/sq.in.	0.069	bar
	lbs/sq.in.	0.070 303	kg/sq.cm
Temperature:	degree F	1.8 F - 32	degree C
Torque:	inch pound	0.112 985	Newton meter
	foot pound	1.355 818	Newton meter
Velocity:	miles/hr.	1.609 344	kilometer/hr.
Volume:	cubic inch	16.387 06	cubic centimeter
	cubic foot	0.028 317	cubic meter
	cubic yard	0.764 555	cubic meter
	ounce (U.S. fluid)	29.573 53	milliliter
	quart (U.S. liquid)	0.946 353	litre
	quart (Imperial)	1.136 523	litre
	gallon (U.S.)	3.785 412	litre
	gallons (Imperial)	4.546 092	litre
Volume/Time:	gallon/min.	3.785 412	litre/min.

---

# NOTES

---

1



# SECTION 2

## HYDROSTATIC DRIVE SYSTEM

Hydrostatic Drive Circuit	2.1
Schematic .....	pg. 2-2
Specifications	2.2
Chart .....	pg. 2-3 ~ 4
General Information	2.3
Introduction .....	pg. 2-5
Trouble Shooting	2.4
Chart .....	pg. 2-6 ~ 8
Diagnose Steps .....	pg. 2-9
Pressure Tests	2.5
Procedure .....	pg. 2-10
Towing Procedure	2.6
Procedure .....	pg. 2-11
Flushing The Hydraulic System	2.7
General Information .....	pg. 2-12
Cleaning .....	pg. 2-13 ~ 14
Start-up Procedure	2.8
Procedure .....	pg. 2-15
Gear Pump Replacement	2.9
Procedure .....	pg. 2-16
Tandem Pump Replacement	2.10
Procedure .....	pg. 2-17 ~20
Tandem Pump Parts Diagram	2.11
Parts Illustrations .....	pg. 2-21 ~ 26
Drive Motor	2.12
General Information .....	pg. 2-27 ~ 30
Removal .....	pg. 2-31 ~ 32
Replacement .....	pg. 2-33 ~ 34
Parts Illustration .....	pg. 2-35 ~ 36
Disassembly .....	pg. 2-37 ~ 44
Assembly .....	pg. 2-45 ~ 52
Torque Specifications	2.13
Torque Chart .....	pg. 2-53



# HYDROSTATIC CIRCUIT 2.1

## Hydrostatic Circuit and System Pressure Schematic

- A** High Pressure Relief at 5000 psi (345 bar)
- B** Aux. Press. Relief Set at 2400 psi (165.5 bar)
- C** System Charge Pressure 200 psi Minimum (13.8 bar)
- D** Return Pressure
- E** Suction Line (Vacuum) 4 - 6 Hg @ 160°F (71°C)

2

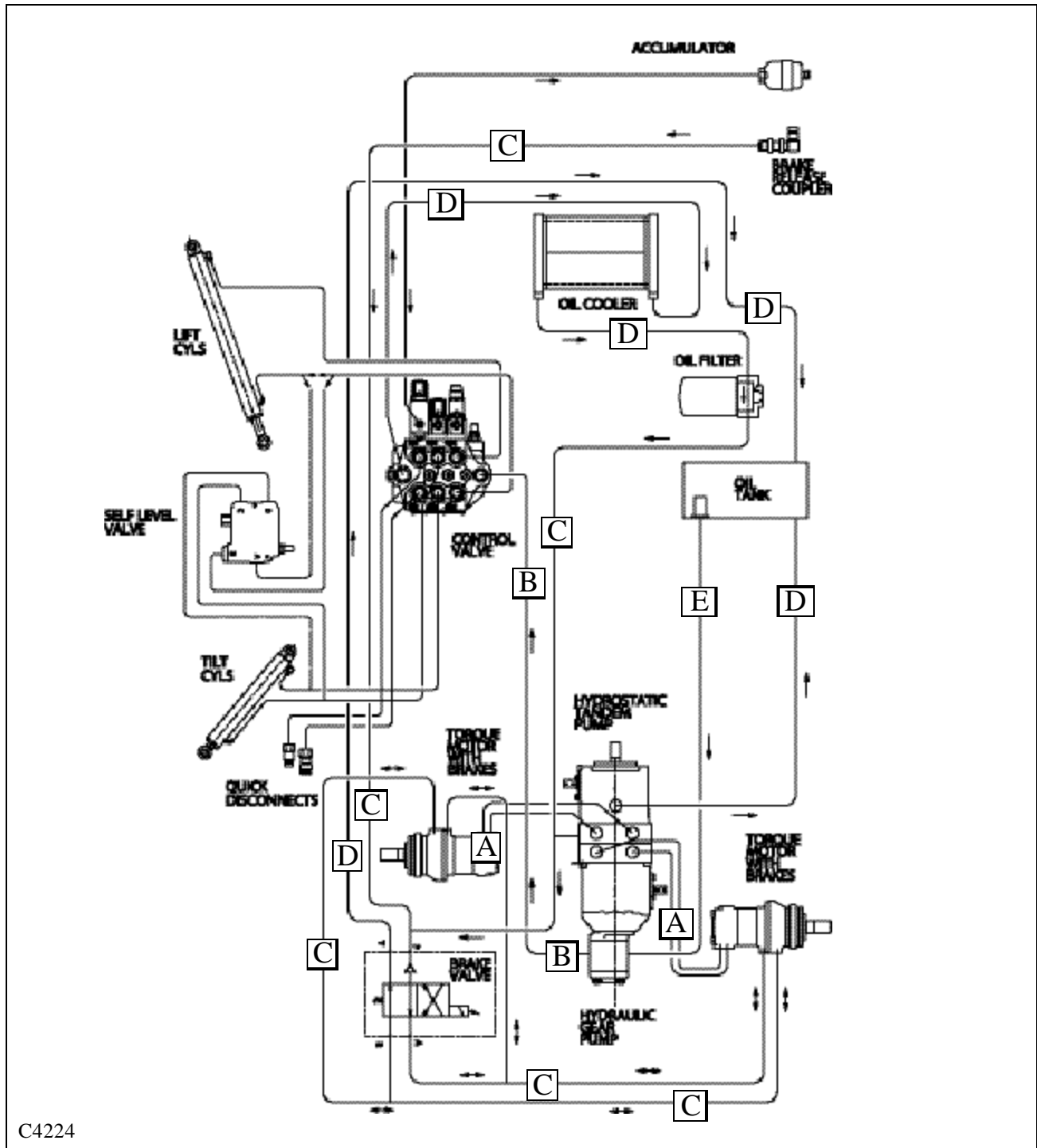

C4224

---

# SPECIFICATIONS 2.2

---

## Hydrostatic Tandem Pump 137/153

Pump Type	Variable Displacement, Reversible Piston
Brand Name of Pump	Sauer Danfoss
Series Type	40
No. Of Drive Pumps	2 (two)
Mounting	Tandem
Rotation (viewed from shaft end)	Clockwise
Operating Speed	2800 rpm (+ / - 25 rpm)
Pump Displacement	2.65 cu in (43.5cc)
Minimum Pump Output (flow)	17.5 gal (64.7 l) / Min @ 1800 rpm @ 2000 psi (137.8 bar) Over Measured Charge Pressure
No. Of Relief Valves	2 (two)
Relief Valve Setting	5000 psi (345 bar)
Max. Allowable Case Pressure	25 psi (1.7 bar)
Charge Pump Type	External: Gear Pump / Sauer-Danfoss
Charge Pressure	200 psi Min. (13.8 bar)
Hydrostatic Repair Manual	Thomas P / N 44232 Sauer Danfoss P / N BLN-9992



## Hydraulic Drive Motor

Drive Motor Type	Geroler Torque Motor With Brake
Brand Name	Sauer Danfoss
Series Type	OMT 500 FLV
Rotation	Dual
No. Of Drive Motors	2 (two)
Drive Motor Displacement	31.9 cu in (523cc)
Max. Case Pressure	250 psi (17.3 bar)

## Reservoir

Fluid Type	10w30 API Class SJ Oil
Reservoir Filtration	One 100 micron Screen Element
Hydraulic Oil Filtration	One 10 micron Element
Hydraulic Element	P / N 35243



---

## SPECIFICATIONS 2.2

---

### Hydrostatic Tandem Pump 1300/135

Pump Type	Variable Displacement, Reversible Piston
Brand Name of Pump	Sauer Danfoss
Series Type	M35
No. Of Drive Pumps	2 (two)
Mounting	Tandem
Rotation (viewed from shaft end)	Clockwise
Operating Speed	2800 rpm (+ / - 50 rpm)
Pump Displacement	2.14 cu in (35cc)
Minimum Pump Output (flow)	13.5 gal. (51 l) / minute @ 1800 rpm @ 2000 psi (137.8 bar) Over Measured Charge Pressure
No. Of Relief Valves	2 (two)
Relief Valve Setting	5000 psi (345 bar)
Max. Allowable Case Pressure	25 psi (1.7 bar)
Charge Pump Type	External: Gear Pump / Eaton
Charge Pressure	200 psi Min. (13.8 bar)
Hydrostatic Repair Manual	Thomas P / N 44232 Sauer Danfoss P / N BLN-9992

### Hydraulic Drive Motor

Drive Motor Type	Geroler Torque Motor With Brake
Brand Name	Sauer Danfoss
Series Type	OMT 500 FLV
Rotation	Dual
No. Of Drive Motors	2 (two)
Drive Motor Displacement	31.9 cu in (523cc)
Max. Case Pressure	250 psi (17.3 bar)

### Reservoir

Fluid Type	10w30 API Class SJ Oil
Reservoir Filtration	One 100 micron Screen Element
Hydraulic Oil Filtration	One 10 micron Element
Hydraulic Element	P / N 35243



## GENERAL INFORMATION 2.3

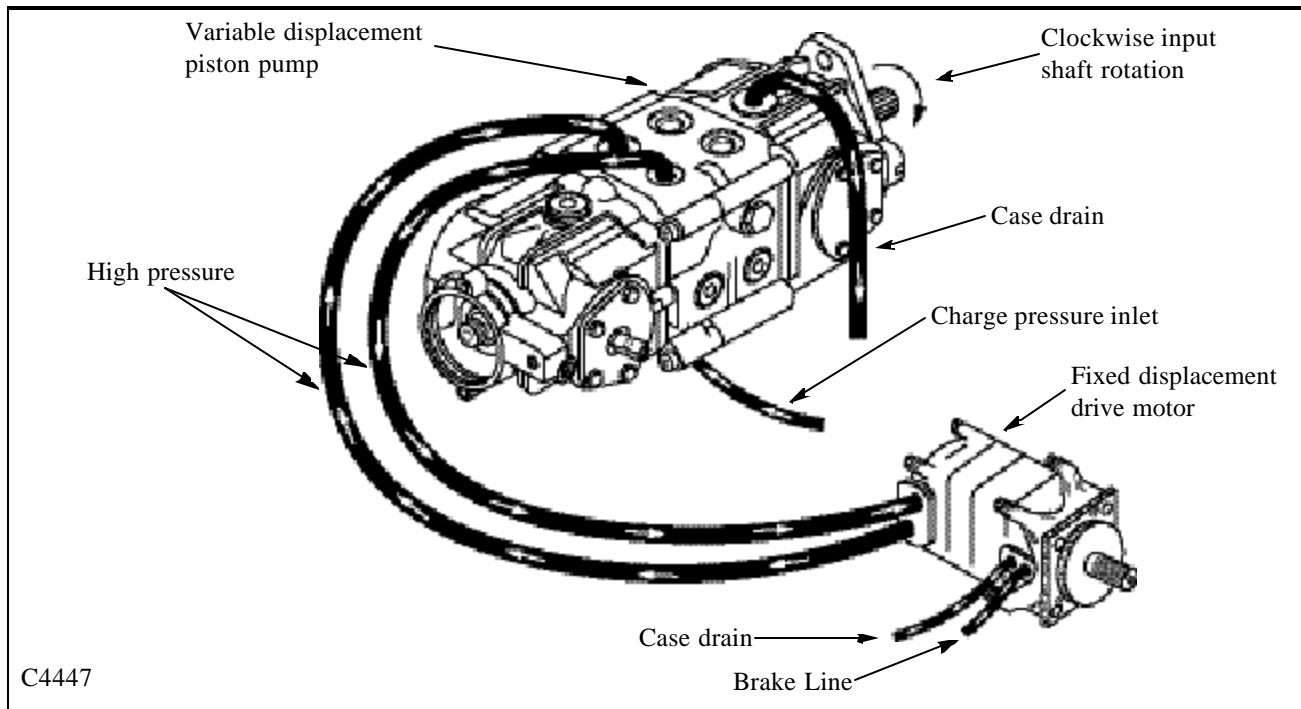

The drive shaft of the piston pump is rotated by the engine. The piston block which is splined to the drive shaft also turns. The piston block, rotating group, consists of 9 piston assemblies which have free swiveling shoes swagged on the ball end of each piston assembly. The shoe end of the piston rides against the smooth machined surface of the swashplate. With the swashplate in the neutral position, the piston assemblies do not reciprocate in the piston block, but are rotating. No oil is drawn into or discharged from the pump. The pump is in a zero displacement position and the loader remains stationary. With the swashplate in the neutral position the pressure of the charge oil, which ranges from 200 to 280 psi (13.8 - 19.3 bar), is able to unseat both check valves and supply oil to both sides of the pump because of the balance in pressure. Very little charge oil volume is required in the neutral position so the excess oil is bypassed over the charge pressure relief valve and recirculated back to the reservoir. The oil that leaks internally in the pump and motor collects in their body housings and is returned to the reservoir by external case drain in the pump and motors. This leakage oil is the only oil the charge check replenishes. This makes the design a closed loop system. As the steering lever is moved forward, or reverse, the loader starts a directional movement. As the swashplate begins to move, the piston assemblies start to reciprocate in the piston block. As the steering lever continues further movement the cam angle increases, the pistons reciprocate further, more oil is pumped and the speed of the loader is increased.

When the swashplate begins to move the check valve on the discharge, or pressure, side seats because of the higher pressure differential. The other check valve remains open on the intake or low pressure side to continue supplying the closed loop system with charge oil.

The drive motor, which is a fixed displacement type, delivers a constant output torque for a given pressure throughout the speed range of the motor.

The movement of the pump swashplate, forward or reverse, controls the direction of the drive motor rotation. The function of the pressure relief valve is to relieve the pressure side of the system of excessive high pressure when the loader encounters a heavy load or stalls out. When the relief valve senses an over load it unseats, allowing excess pressure and volume to flow into the low pressure side of the pump. A small volume of oil starts to flow across to the other relief valve. This relief valve is exposed to the low pressure on the intake side of the pump and is seated by the spring tension within the relief valve body.

The small volume of oil being bypassed is enough to unseat the relief valve and let it recirculate back into the inlet side of the pump. As the pressure continues to build on the pressure side, a larger volume of oil flows and at a greater speed through the drilled orifice in the relief valve cartridge, causing a pressure drop inside the relief valve. The surrounding pressure is now able to unseat the relief valve and bypass maximum volume of oil. The system reliefs function the same for both sides of the system.

# TROUBLE SHOOTING 2.4

Symptom: Neutral Difficult Or Impossible To Find

2

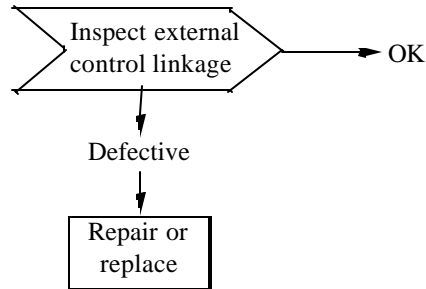

Symptom: System Operating Hot

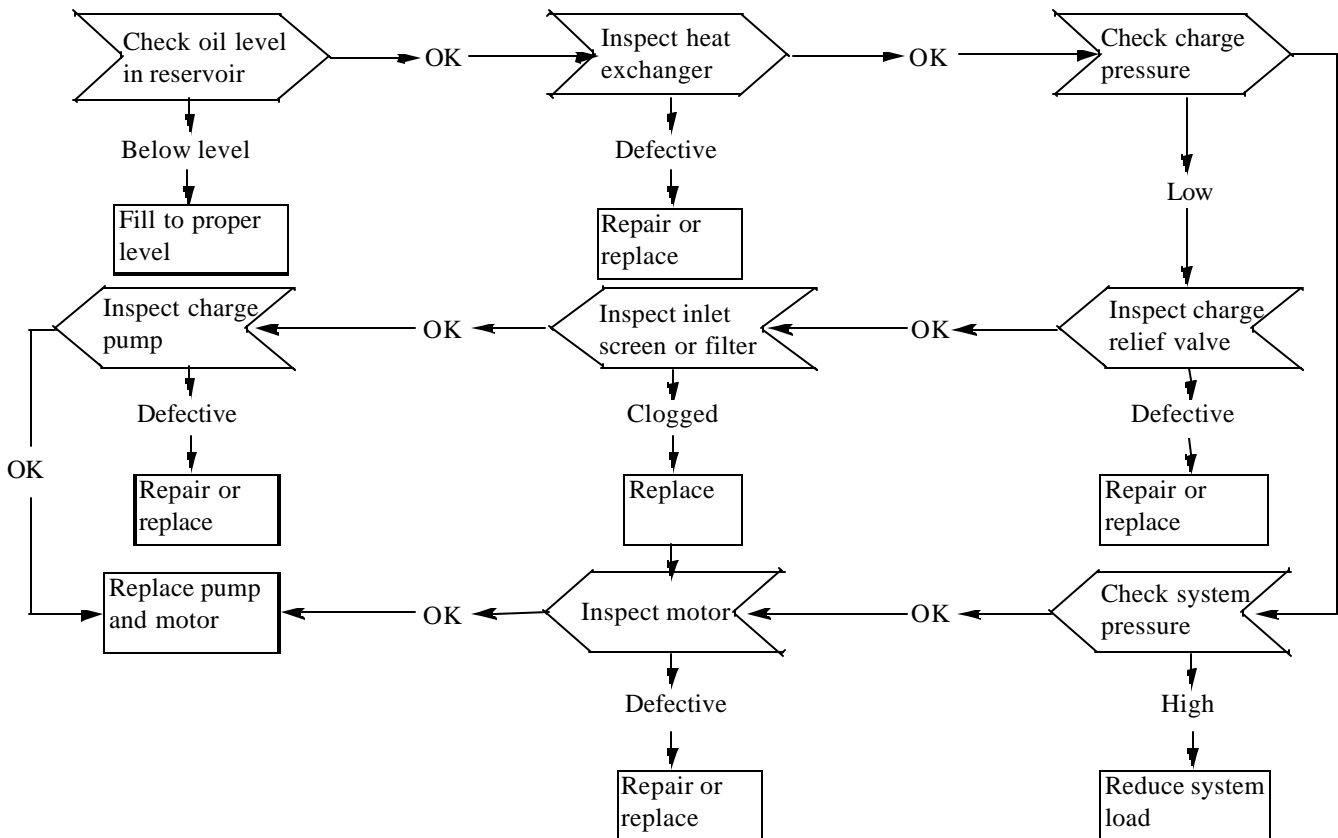

# TROUBLE SHOOTING 2.4

Symptom: Operates In One Direction Only

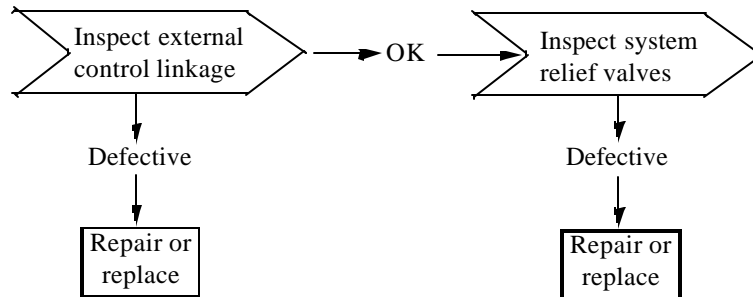

Symptom: System Response Sluggish

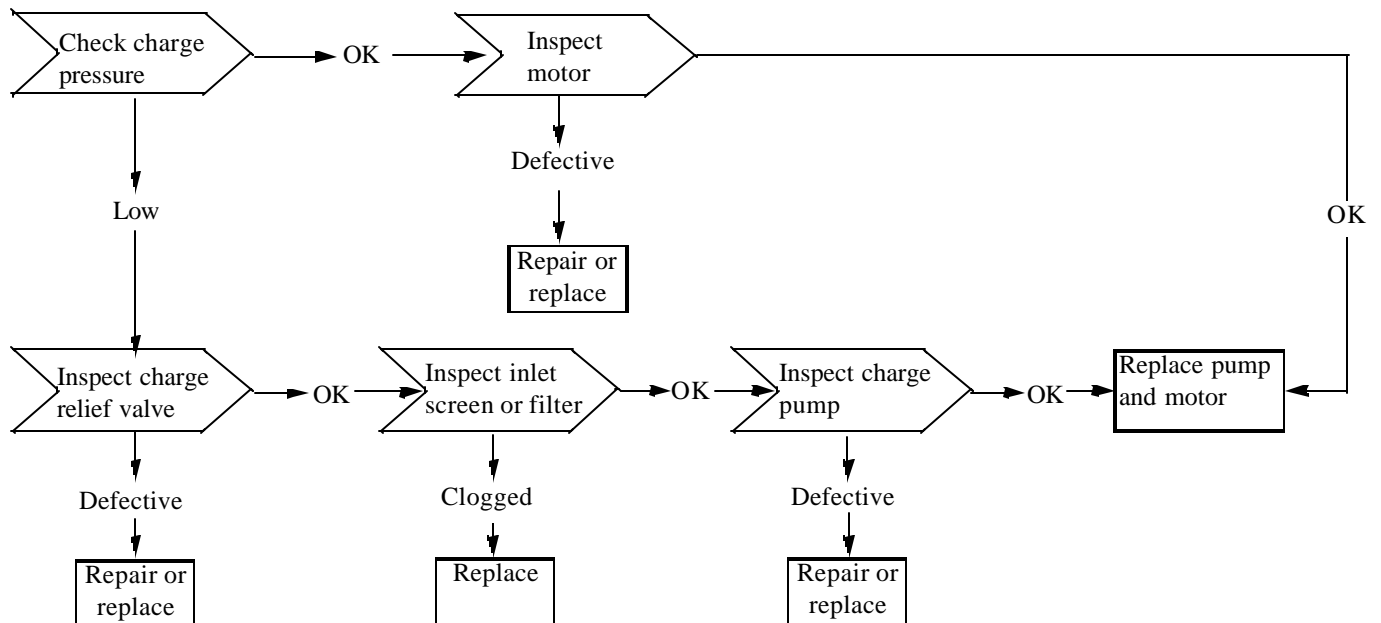

# TROUBLE SHOOTING 2.4

Symptom: System Will Not Operate In Either Direction

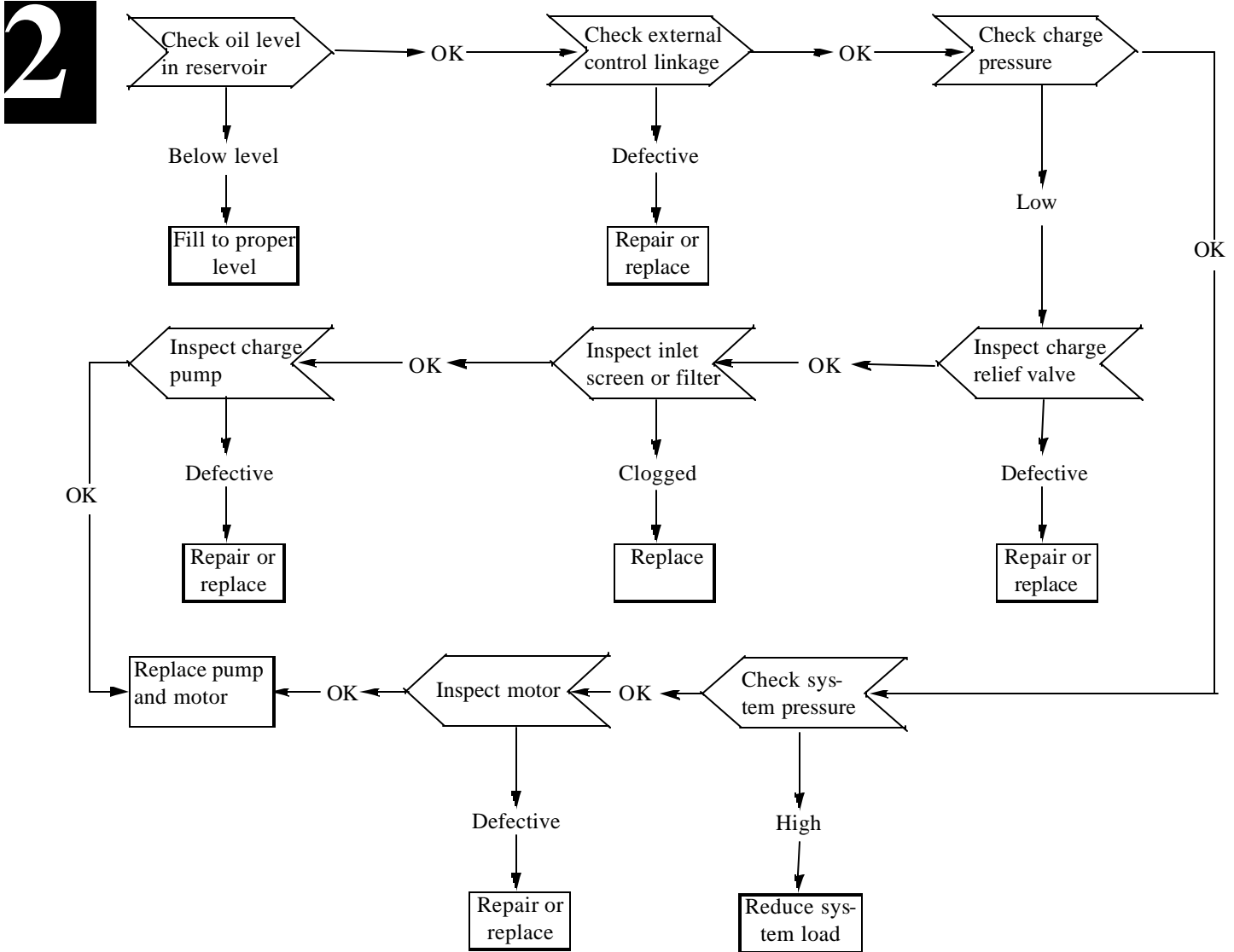

# TROUBLE SHOOTING 2.4

## System Diagnosing Steps And Special Tools

- 1 Check oil level in reservoir:**
  - a. fill to proper level as marked on site tube.
- 2 Inspect external control linkage for:**
  - a. misadjustment or disconnection
  - b. binding, bending or breakage
  - c. misadjusted, damaged or broken hydroback
- 3 Inspect servo control valve for: ( if used )**
  - a. proper inlet pressure
  - b. misadjusted or damaged neutral return spring
  - c. galled or stuck control spool
  - d. galled or stuck servo piston
- 4 Inspect heat exchanger for:**
  - a. obstructed air flow
  - b. improper plumbing ( inlet to outlet )
  - c. obstructed fluid flow
- 5 Inspect inlet filter or screen for:**
  - a. plugged or clogged screen or filter
  - b. obstructed inlet or outlet
  - c. open inlet to charge pump ( open line )
- 6 Check charge pressure:**
  - a. follow test procedures section 2.5
- 7 Inspect charge relief valve for:**
  - a. poppet held off seat
  - b. damaged or broken spring
  - c. damaged valve seat
  - d. improper charge relief setting
- 8 Inspect charge pump for:**
  - a. broken or missing drive coupling
  - b. damaged or missing o-rings
  - c. galled or broken gerotor set
- 9 Inspect system relief valves for:**
  - a. damaged or broken springs
  - b. valve held of seat
  - c. damaged valve seat
  - d. improper pressure relief settings
- 10 Check system pressure:**
  - a. follow test procedures section 2.5
- 11 Inspect hydraulic motor for:**
  - a. disconnected coupling

Photographs in the right hand column show some of the special tools that may be required to diagnose and repair the hydrostatic system.

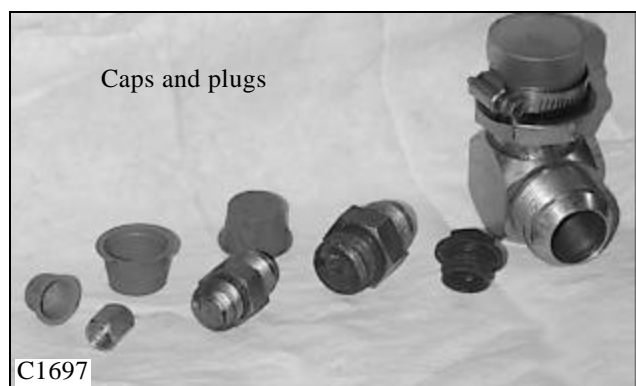
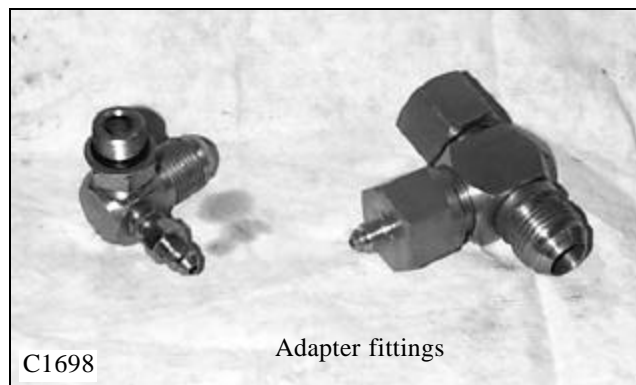
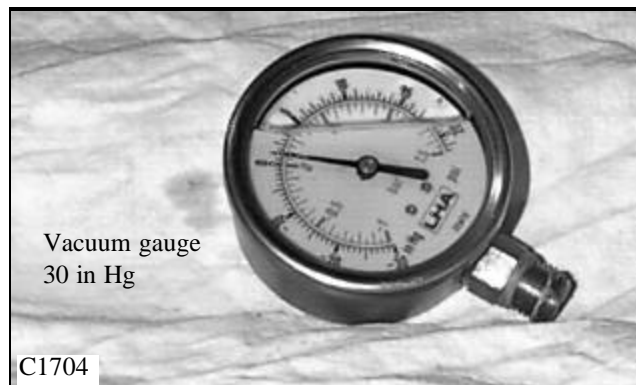
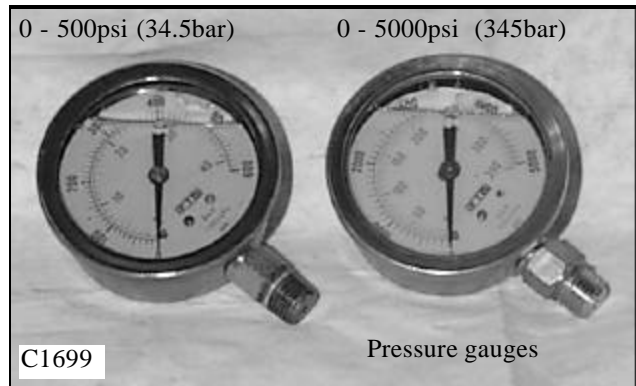

2

# PRESSURE TESTS 2.5

The following photos show the various port locations available on the hydrostatic tandem pump for checking system pressure.

Completing these pressure tests will diagnose any mechanical problem in the hydrostatic system.

# 2

**WARNING**

**Use caution when dealing with hydraulic fluid under pressure. Escaping fluid under pressure can penetrate the skin and cause serious injury.**

Installing a gauge into the system gauge port 'A', 'B', 'C' or 'D' will verify the status of the high pressure relief valves.

Checking the pressure at port 'E' will give accurate charge pressure reading. The charge pressure can also be obtained by placing a gauge on the quick coupler in the engine compartment. (fig C4258)

Checking the pressure at port 'F' will verify case drain pressure.

Gauge Information		
A	System Pressure Gauge	10,000 psi gauge (690 bar) 9/16 - 18 O-Ring Fitting
B	System Pressure Gauge	10,000 psi gauge (690 bar) 9/16 - O-Ring Fitting
C	System Pressure Gauge	10,000 psi gauge (690 bar) 9/16 - O-Ring Fitting
D	System Pressure Gauge	10,000 psi gauge (690 bar) 9/16 - O-Ring Fitting
E	Charge Pressure Inlet Port	500 psi Gauge (34.5 bar) 7/8 - 14 O-Ring fitting
F	Case Drain Port	500 psi Gauge (34.5 bar) 1 - 1/16 - 12 O-Ring Fitting

Tandem pump flow can also measure pump performance.

- 1 Connect a flow meter between the high pressure ports, one section at a time.
- 2 Start the engine and increase operating speed between 1775 ~ 1800 rpm.
- 3 Restrict the flow to show 2000 psi (137.8 bar) over charge pressure inlet.  
Example: Charge pressure = 220 psi (15.2 bar) Gauge pressure reading would need to be 2220 psi (153 bar).
- 4 Minimum flow reading should be 13.5 gal / min. (51 l / min).

LH Side And Top View

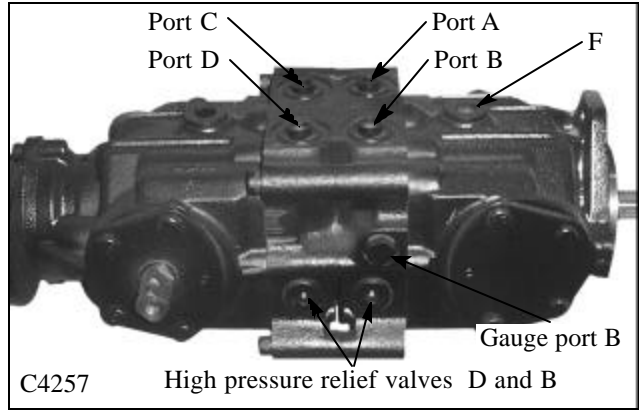

**NOTE:** Without Internal charge pump model shown

RH Side and Bottom View

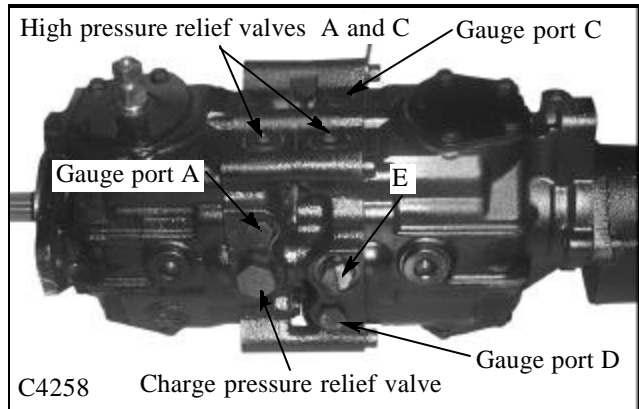

**WARNING**

**Raise the machine securely from the ground before performing system checks to prevent sudden movement.**

# TOWING 2.6

## Towing Procedure

In an event the loader has malfunctioned or failed, the loader may be moved a short distance by following the procedure below.



### WARNING

**Failure to follow the proper towing procedure may cause damage to the hydrostatic drive system.**

- 1 Remove the seat and hydrostatic shield.
- 2 Loosen the high pressure relief valve caps 4 complete turns. There are 4 high pressure relief valves, 2 on the left hand side, and 2 on the right hand side of the tandem pump. Be sure to loosen all 4. ( fig. C1882 ) Torque caps 30 to 50 ft lbs (41 to 68 N m) upon reassembly.
- 3 The loader parking brake system is released by hydrostatic pressure. To release the parking brake when the unit has failed you must pressurize the brake system manually. A service override for the brake valve has been incorporated for use by Thomas Dealers. The normal position of the plunger is down and turned into the locked position. To release the brake, turn the release plunger counter clockwise. (fig. C1884) Next, go to the rear of the loader and access the small quick connector located next to the hydraulic oil filter in the engine compartment. (fig. C1472) This could be located on the left or right hand reservoir. Use a port -a - power to pressurize this line to 200 psi (13.8 bar). The brakes are now released.



### WARNING

**Be sure to return the brake valve plunger to the normal position after servicing the loader.**



### CAUTION

**To prevent damage to the drive motors, do not exceed speed of 1 MPH.**

- 4 Use the front frame mounted tie downs to attach pulling devise. ( fig. C3447 ) Use the rear tie downs to pull the loader backwards. ( fig. C3446 )



### WARNING

**Use chains or cables rated a minimum of 1 and 1/2 times the gross vehicle weight.**

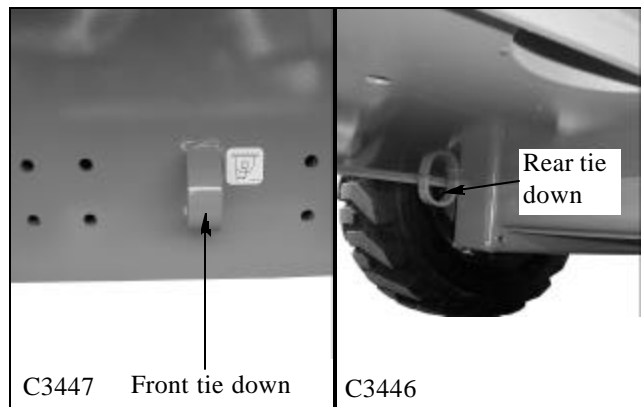
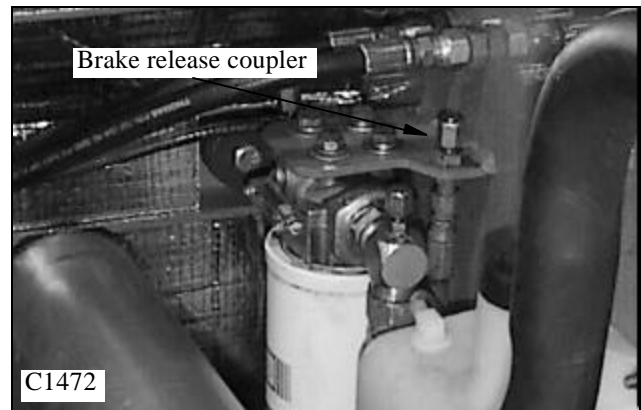
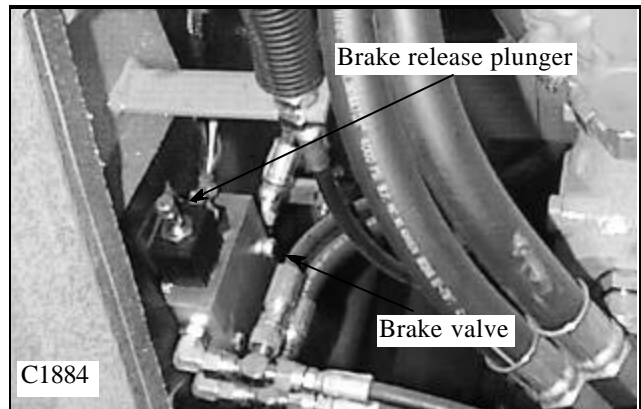
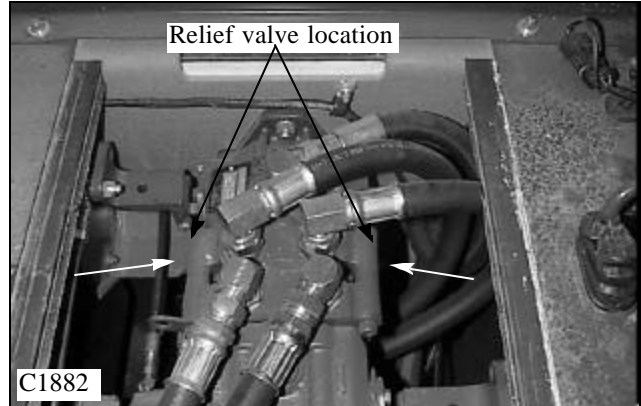

2



# FLUSHING THE HYDRAULIC SYSTEM 2.7

## 2

### General Information

Contamination in the hydraulic system is a major cause of component failure. Contamination can enter the hydraulic system in any of the following ways.

- 1 When draining the hydraulic system.
- 2 When disassembling components.
- 3 Making auxiliary connections with dirty couplers.
- 4 Normal component wear.
- 5 Component failure

The best way to remove contaminants from the hydrostatic drive system is to disassemble each component and flush and clean thoroughly.

The hydraulic control circuits may be cleaned by attaching a suitable hydraulic filter to the auxiliary couplings and circulating the fluid through it.

### Contamination Types

There are 2 types of contamination, microscopic, or non visible, and visible. Microscopic contamination is suspended in the fluid and moves freely through the hydraulic circuits. Examples of problems caused by microscopic contaminants include the following:

- 1 Cylinder rod seal leaks.
- 2 Control valve spools do not return to neutral.
- 3 Hydraulic system has a high operating temperature.
- 4 Components wear rapidly.

Visible contamination is foreign material that can be found by sight, touch or odor. Some examples of visible contamination include the following:

- 1 Particles of metal or dirt in the oil.
- 2 Air in the oil.
- 3 Odor of burned oil.
- 4 Water in the oil.

# FLUSHING THE HYDRAULIC SYSTEM 2.7

## Cleaning The System

The first step in cleaning the hydraulic system is to determine if you have visible or microscopic contamination.

If the contamination is visible, do the following steps:

- 1 Change the hydraulic oil by removing the drain plug in the bottom of the hydraulic oil reservoir. (fig. C4446) Be prepared to contain approximately 30 litres of fluid.
- 2 Check the extent of the contamination by disassembling 1 each of the hydraulic cylinders. Check the cylinders for damage. Repair or replace the cylinders as required. If you determine the damage was caused by severe contamination and is not the result of normal wear, it will be necessary to remove, clean and repair all valves, pumps, lines, cylinders, etc.

- 3 Replace all hydraulic filters.

If the contamination is determined to be microscopic, perform the following steps:

- 1 Change the hydraulic oil by removing the plug in the bottom of the oil reservoir. (fig. C1034) Be prepared to contain approximately 30 litres of fluid.
- 2 Connect an external 10 micron filtering system, capable of sustaining minimum of 2000 psi (138 bar) and has a back pressure gauge, to the auxiliary couplings. (fig. C1687, C1688)
- 3 Start the engine and let it idle at approximately half throttle.



### WARNING

**Be sure to use a filtering system capable of handling the pressure of the hydraulic system.**

- 4 Engage the auxiliary circuit. Check to make sure the filtering system is not over taxed by the loaders hydraulic system pressure. Adjust engine idle accordingly to match the filtering systems capacity. This may vary as the filter becomes dirty, you may need to decrease engine rpm. Circulate the oil through filter for 30 minutes.

- 5 As the oil is being circulated through the auxiliary circuit, raise the liftarms up and down in full stroke cycles. Repeat this exercise for 15 minutes.

- 6 Cycle the bucket tilt cylinders in the same manner as above. Repeat the exercise, in full extension and retraction, for 15 minutes.

- 7 Install new hydraulic oil filters. (fig. C1472)

- 8 Start the engine and check for leaks. Replenish the hydraulic oil reservoir as required. (fig. C1878)

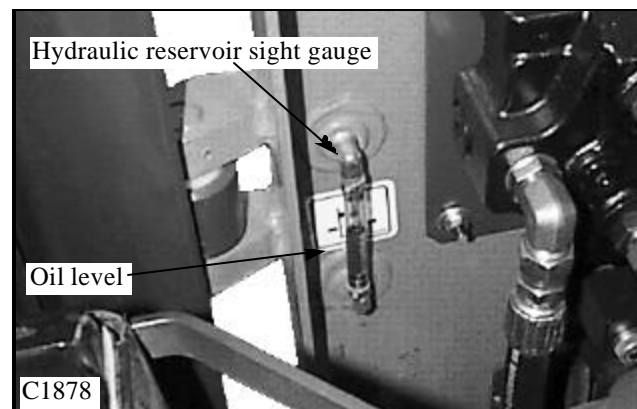
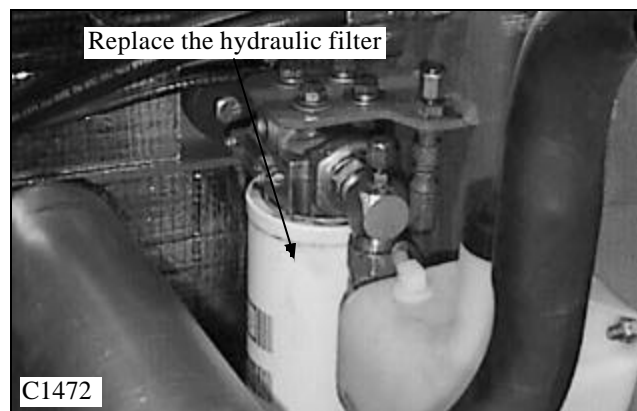
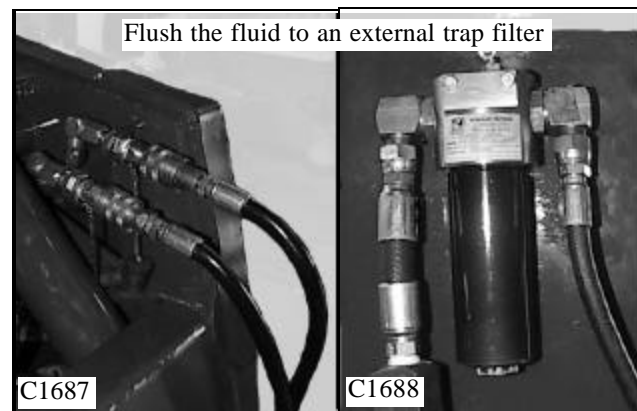
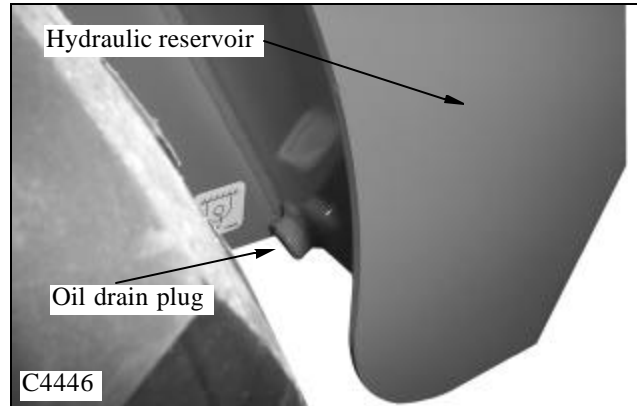

2

# FLUSHING THE HYDRAULIC SYSTEM 2.7

For flushing water from the hydraulic system, perform the following procedures:

## IMPORTANT

**Be sure attachments are removed and liftarm are in the lowered position.**

- 1 Remove any attachment.
- 2 Make sure all cylinders are fully retracted.
- 3 Change the hydraulic fluid. (fig. C4446)
- 4 Change the hydraulic filter. (fig. C1472)
- 5 Disconnect the hydraulic lines from one set of cylinders. (fig. C4251, C1336)
- 6 Start the engine and set to the lowest idle.



## WARNING

**Use caution when dealing with hydraulic fluid under pressure. Escaping fluid under pressure can penetrate the skin and cause serious injury.**

- 7 Have someone hold the open hydraulic lines into a container. Stroke the foot pedals, or hand operated, controls slowly. Continue to repeat this cycle until the oil comes out clear. Repeat for opposite set of cylinders.

## IMPORTANT

**Check the hydraulic oil frequently during this procedure. Replenish as required.**

- 8 Attach a hose and couplings to the auxiliary circuit. Engage the auxiliary hydraulics, forward and reverse, until the oil flows clear.
- 9 Connect 1 hose each, on each cylinder, to the fixed end of the cylinder barrel.
- 10 Move the foot pedal or control lever to extend the cylinder rods. This will flush the oil from inside the cylinder barrels. Be prepared to contain the waste oil.
- 11 Stop the engine.
- 12 Connect the hydraulic hoses to the rod end of the cylinder barrel.
- 13 Replenish the hydraulic oil as required.

## IMPORTANT

**Please contain and dispose of waste oil in an environmentally friendly manner.**

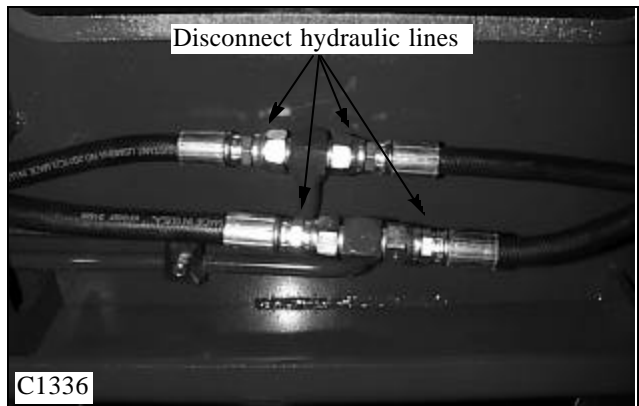
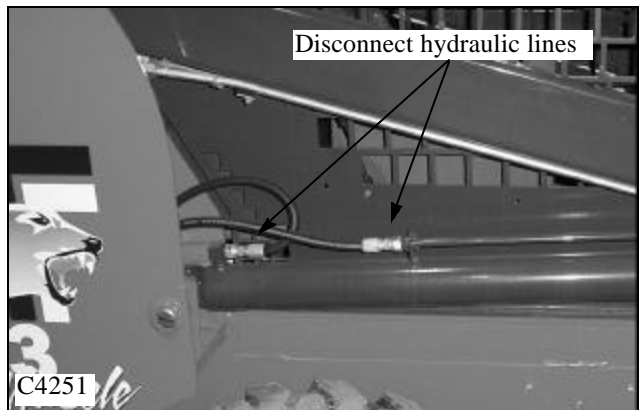
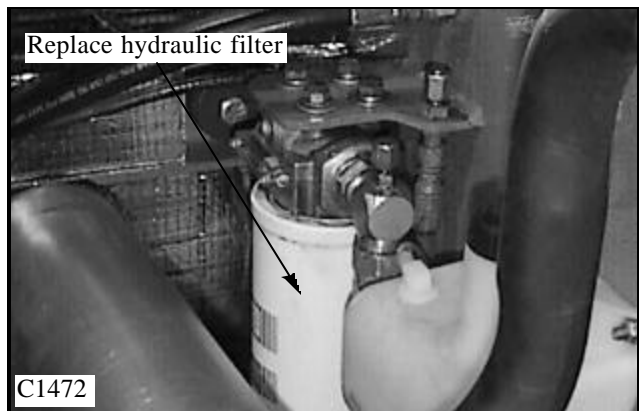
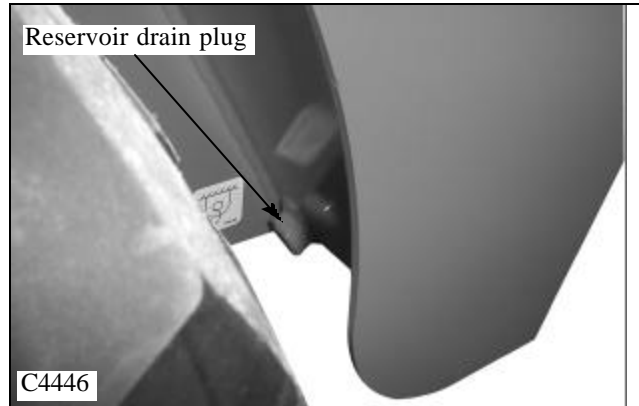

# START-UP PROCEDURE 2.8

The following start-up procedure should always be adhered to when starting up a new installation or when restarting after pump repairs have been made.

1 Fill the hydraulic oil reservoir to the proper level. ( fig. C1878 )



## WARNING

**This start-up procedure must be made with the loader securely raised off the ground.**

2 Check inlet and pressure hose fittings for proper tightness prior to starting.

4 The pump must be filled prior to start-up with filtered oil. Fill the pump by pouring oil into the case drain port. (fig. C4257 location "F" ) In the case of this loader, the case drain is filled by gravity from the tank. The fitting should loosen be double checked that there is oil present.

5 Disconnect the engine stop solenoid wiring, or remove the fuse connected to the red wire. (fig. C1887, C1692)

6 Turn the engine over by engaging the starter. Repeat this step, turning the engine over in 15 second interval, 5 or 6 times. This will fill the rest of the hydraulic hoses.

7 Reconnect the engine stop solenoid or replace the fuse.



## WARNING

**Use caution when dealing with hydraulic fluid under pressure. Escaping fluid under pressure can penetrate the skin and cause serious injury.**

8 Start the engine and let idle at lowest possible setting.

9 Check for leaks and make adjustments as required. Do not use your hands to check for leaks while the engine is operating.

10 Replenish the hydraulic oil reservoir as required. (fig C1690 fig C1878)

11 Start the engine and increase the rpm to half throttle. Bring the hydraulic fluid up to operating temperature and make control adjustments as outline in Section 4.

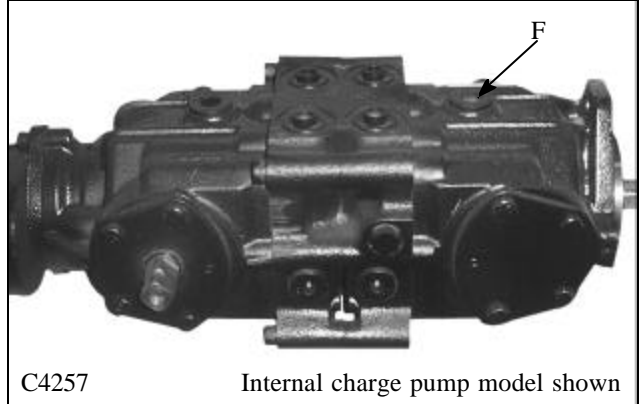

Solenoid wire connector



Fuse panel

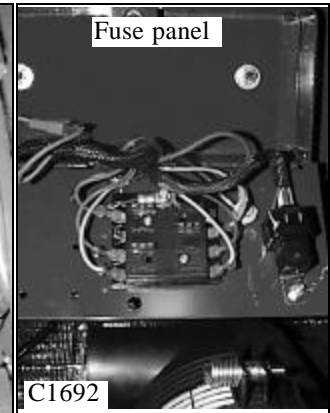

Reservoir sight gauge

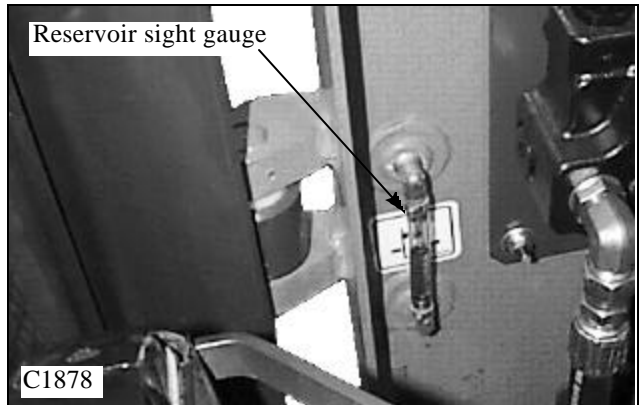

2

# GEAR PUMP REPLACEMENT 2.9

Start the gear pump removal procedure by removing any attachment, raising the boom arms and engaging the boom support pins. Shut off the engine.

1 Remove the seat and hydrostatic shield.



## WARNING

**To prevent personal injury do not work under the boom arms without the boom supports engaged.**

2 Attach a vacuum system to the hydraulic oil reservoir filler location. ( fig. C4227 ) Or drain the oil reservoir.

Seal the threads on the drain plug, if removed, with teflon tape or a liquid form of pipe sealant before re - installing.

3 Disconnect the hydraulic hoses from the gear pump. ( fig. C4259) Remove the pump fittings. Cap all open hoses to prevent contamination. After capping ends you may unhook vacuum system from oil reservoir.

4 Remove the 2 bolts holding the gear pump to the hydrostatic tandem section. ( fig. C4259a) Remove the gear pump.

5 Replace gear pump in reverse order.

## IMPORTANT

**If gear pump replacement is being done because of failure, the hydraulic system and oil should be checked for contamination.**

6 If the hydraulic system has been contaminated by pump or other failure you must follow the cleaning procedure outlined in section 2.7.

7 Start the engine and check for leaks. Do not use your hands to find leaks.



## WARNING

**Use caution when dealing with hydraulic fluid under pressure. Escaping fluid under pressure can penetrate the skin and cause serious injury.**

8 Check the fluid level in the hydraulic oil reservoir and replenish as required. (fig. C1878)

## IMPORTANT

**When making repairs to the hydraulic system, keep the work area and parts clean. Use caps and plugs on all open lines and ports.**

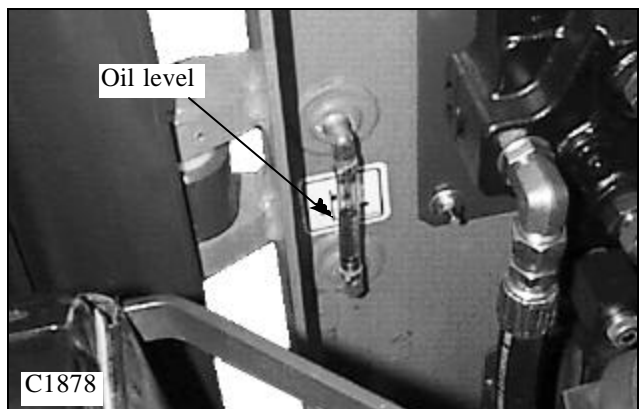
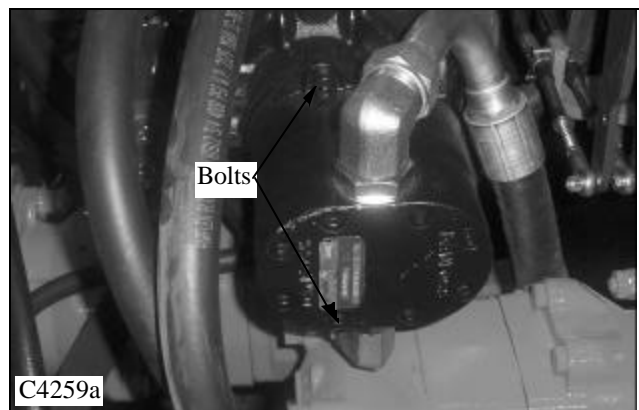
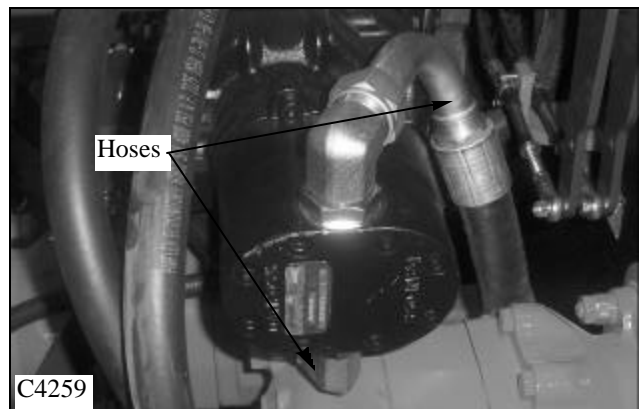
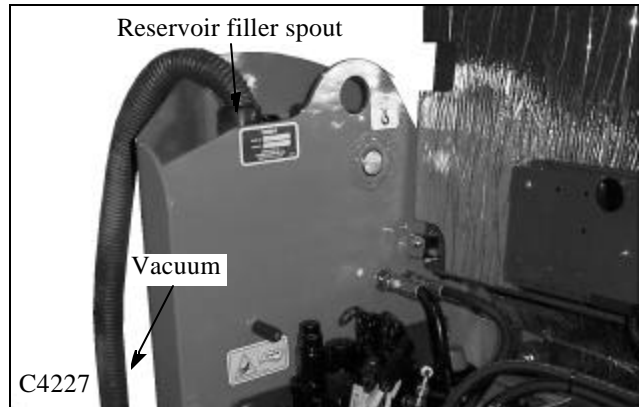

# TANDEM PUMP REPLACEMENT 2.10

Begin the pump removal by removing any attachment, raise the boom arms and engage the boom support pins. Shut off the engine.

- 1 Remove the seat and hydrostatic shield.



## WARNING

**To prevent personal injury do not work under the boom arms without the boom supports engaged.**

- 2 Remove the steering lever linkage. Refer to section 4 for removal and replacement information.
- 3 Remove the gear pump as outlined in section 2.9.
- 4 Disconnect all the hydraulic hoses. (fig. C1885)  
Mark hose and fitting location if necessary to ease re-assembly. Upon re-assembly, torque the hydraulic fittings and hoses as outlined in the Torque Chart in Section 2.13  
Cap all open lines and ports.
- 5 Remove fittings from the tandem pump to prevent damage while removing pump. Plug all open ports and keep the fittings in a clean area. Inspect fittings and o-rings for damage, replace as required.
- 6 Loosen the forward lower mounting bolt on the tandem pump mounting bracket. (fig. C2068)

## IMPORTANT

**When making repairs to the hydraulic system, keep the work area and parts clean. Use caps and plugs on all open lines and ports.**

- 7 Remove the 2 nuts on the u-joint access panel (fig. C4260) to gain access to the rear mounting bolts for the tandem pump. Tip the top of the panel rearward and pull the panel forward to remove.
- 8 Attach a lifting device to the tandem pump. The pump is fairly heavy, approximately 100 lbs. (45 Kg) It is highly recommended to use a mechanical lifting device to assist removal of the tandem pump.
- 9 Remove the 2 rear mounting bolts by access through the u-joint access panel and remove the front mounting bracket. Remove tandem pump from the loader.



## CAUTION

**To prevent possible personal injury, do not attempt to lift heavy objects without assistance.**

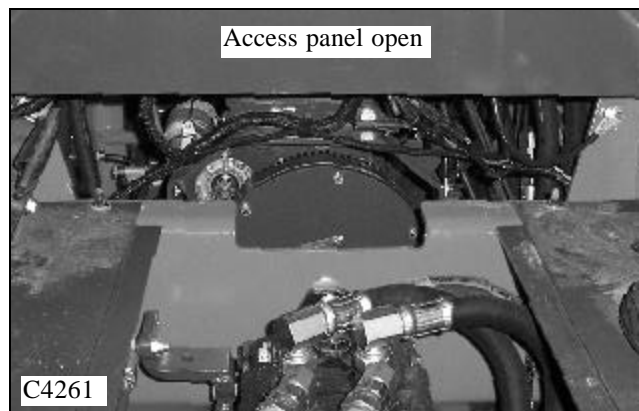
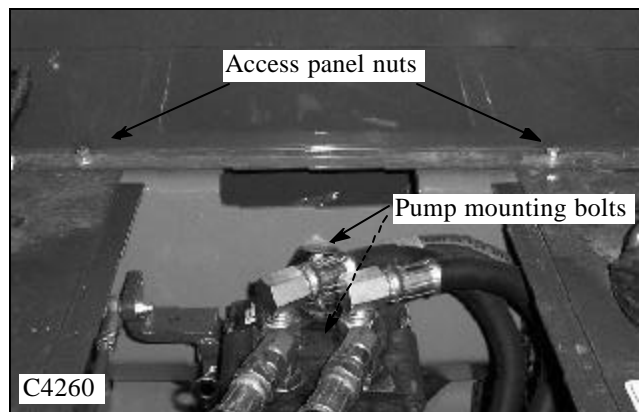
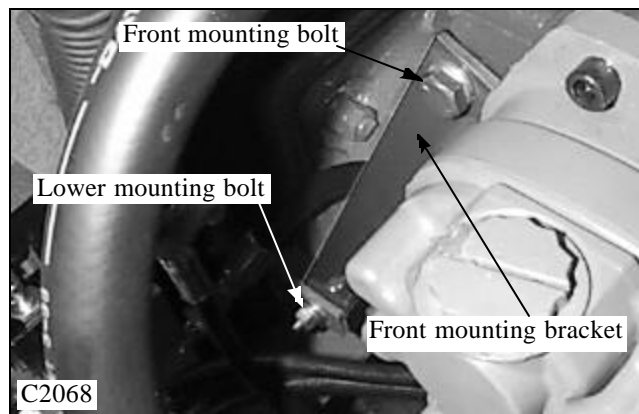
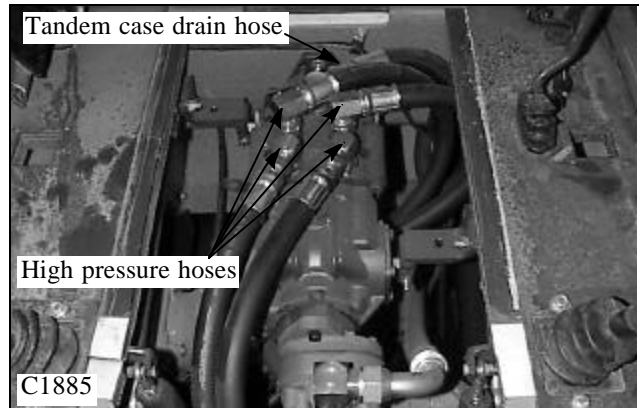

2

# TANDEM PUMP REPLACEMENT 2.10

Upon reassembly, inspect the outside area of the tandem pump housing for damage that may have occurred in transit or handling.

- 1 Attach a lifting device to the tandem pump.
- 2 Install the lower charge pressure inlet fitting to the tandem pump and attach the brake valve hose. (fig. C2069) Follow the torque chart on page 2 - 53.
- 3 Install the tandem pump to the loader.

## WARNING

**To prevent personal injury, do not attempt to lift heavy objects without assistance.**

- 4 Line up the u-joint to the tandem pump input splined shaft as you guide the pump into it's mounting location. (fig. C2070)
- 5 Install the 2 rear mounting bolts.
- 6 Line up the front mounting brace holes and install the bolt. (fig. C2068)
- 7 Torque the 2 rear mounting bolts to 60 ft lbs. (82 Nm) Torque the front pump bracket mounting bolt to 50ft lbs (68 Nm) Torque the front lower mounting bracket bolt at 20 to 25 ft lbs. (32 Nm) Remove the lifting device.

8 Connecting the 4 high pressure drive hoses and fittings to the tandem pump can only be accomplished in a certain sequence. (fig. C2071) Follow the Torque Chart in Section 2.13, page 2 - 53 when tightening fittings and hoses. If you have removed the hoses completely use the following pattern to reconnect:

- A Hose no. 1 connects to the bottom port of the left hand drive motor.
- B Hose no. 2 connects to the top port of the left hand drive motor.
- C Hose no. 3 connects to the top port of the right hand drive motor.
- D. Hose no. 4 connects to the bottom port of the right hand drive motor.

9 Connect the charge inlet hose from the oil filter to the tandem pump. Torque the fittings and hoses according to the Torque Chart in Section 2.13 page 2 - 53.

## IMPORTANT

**When making repairs to the hydraulic system, keep the work area and parts clean. Use caps and plugs on all open line and ports.**

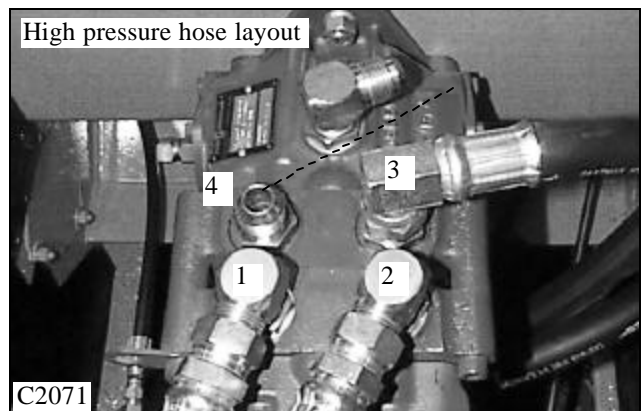
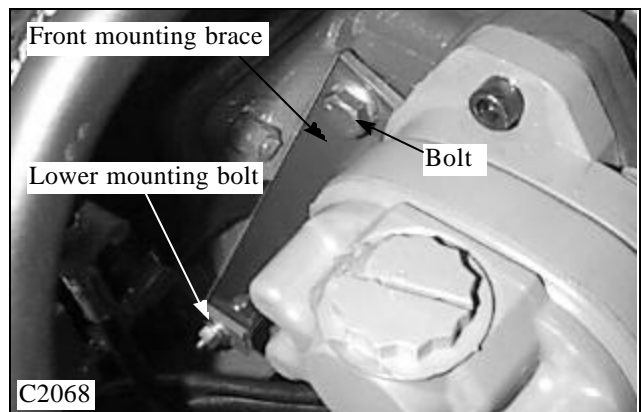
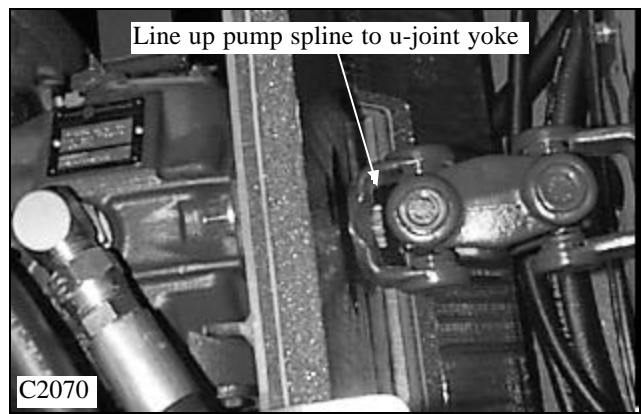
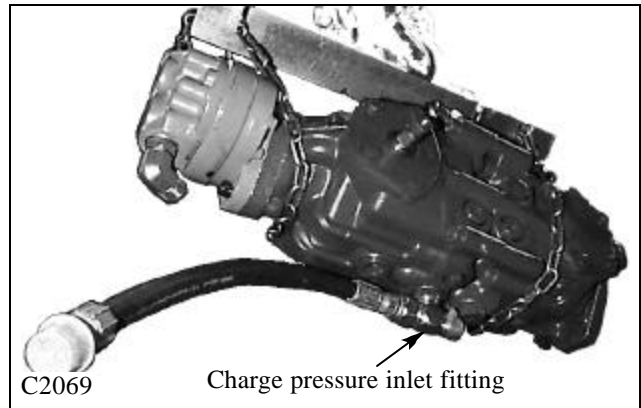

# TANDEM PUMP REPLACEMENT 2.10

10 Connect the tandem pump case drain fitting and hose. Torque the fittings and hoses to the specifications listed in the Torque Chart in Section 2.13 page 2 - 53.

## IMPORTANT

When making repairs to the hydraulic system, keep the work area and parts clean. Use caps and plugs on all open line and ports.

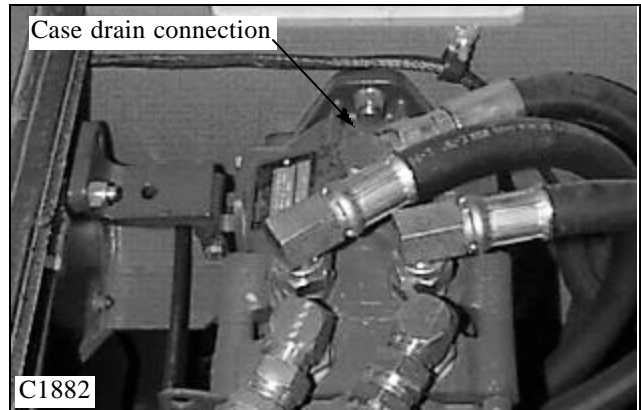

11 Connect the auxiliary gear pump outlet fittings and hoses to the gear pump. (fig. C4259) Follow the Torque Chart in Section 2.13 page 2 - 53 when tightening fittings and hoses.

## IMPORTANT

Inspect fitting o-rings and flares for marks or damage. Replace if necessary.

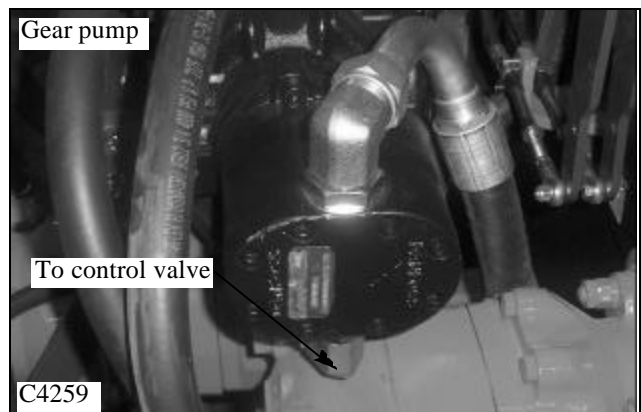

12 Connect the inlet fitting and hose to the auxiliary gear pump. (fig. C4259a) Torque the fittings and hoses to the specifications listed in the Torque Chart Section 2.13.

## IMPORTANT

Follow the Torque Chart In Section 2.13 when tightening fittings and hoses.

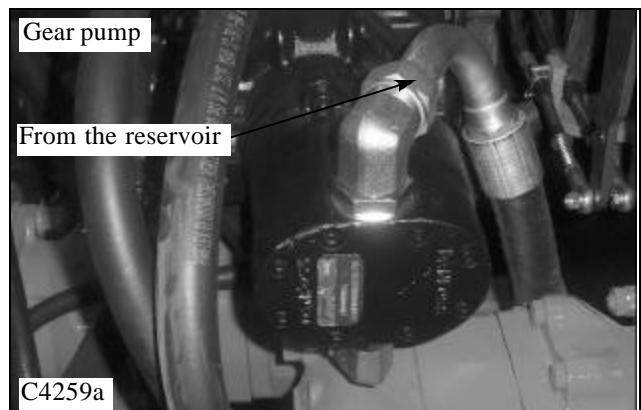

13 Connect the charge pressure outlet line from the tandem pump to the hydraulic brake valve. (fig. C2072)

## NOTE:

The 137 / 153 use a Sauer Danfoss M44Tandem Pump. The 1300 /135 use a M35 Tandem Pump.

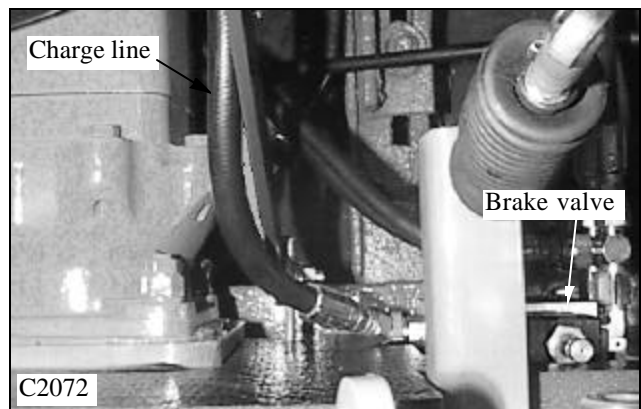

2



# TANDEM PUMP REPLACEMENT 2.10

14 Reinstall the steering control linkages and locks as outlined in Section 4. ( fig. C1857 )

15 Fill the hydraulic oil reservoir to the proper level.

## IMPORTANT

**Follow the start up procedure outlined in section 2.8 upon restarting after pump repairs or replacement.**

16 Follow the start up procedure outlined in section 2.8 before attempting to start the loader.

## WARNING

**This start-up procedure must be made with the loader securely raised off the ground.**

17 The start up must be made with the loader raised securely from the ground. Changing the pumps and the steering control linkages has affected the neutral adjustment. Failure to raise the loader clear of the ground may result in the loader engaging in motion and possibly causing serious injury.

## WARNING

**To prevent personal injury never make repairs to the hydraulic system while the engine is operating.**

18 Start the loader and check for leaks. Make repairs as necessary and replenish the hydraulic oil reservoir. Never use your hands to check for hydraulic leaks.

## WARNING

**Use caution when dealing with hydraulic fluid under pressure. Escaping fluid under pressure can penetrate the skin and cause serious injury.**

19 Make adjustments to the steering controls, steering locks, and restraint bar cables as required. Follow the procedures for control adjustments in Section 4

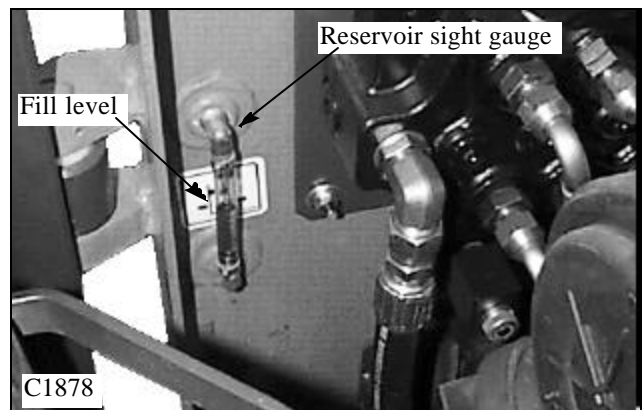
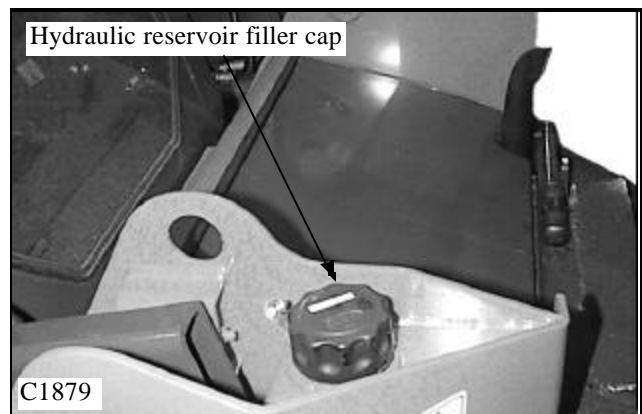
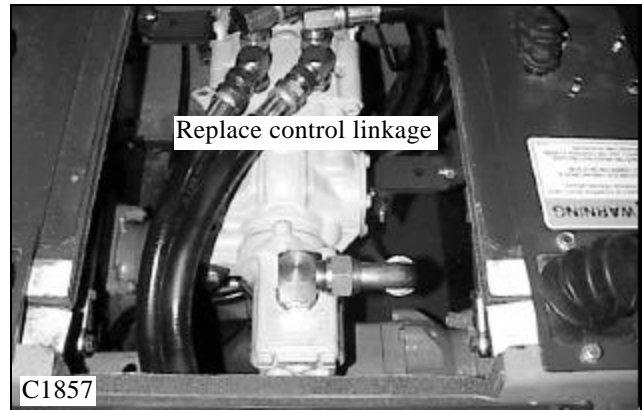

## NOTE:

**The 137/ 153 use a Sauer Danfoss M44 Tandem Pump. The 1300 /135 use a M35 Tandem Pump.**

# TANDEM PUMP PARTS DIAGRAM 2.11

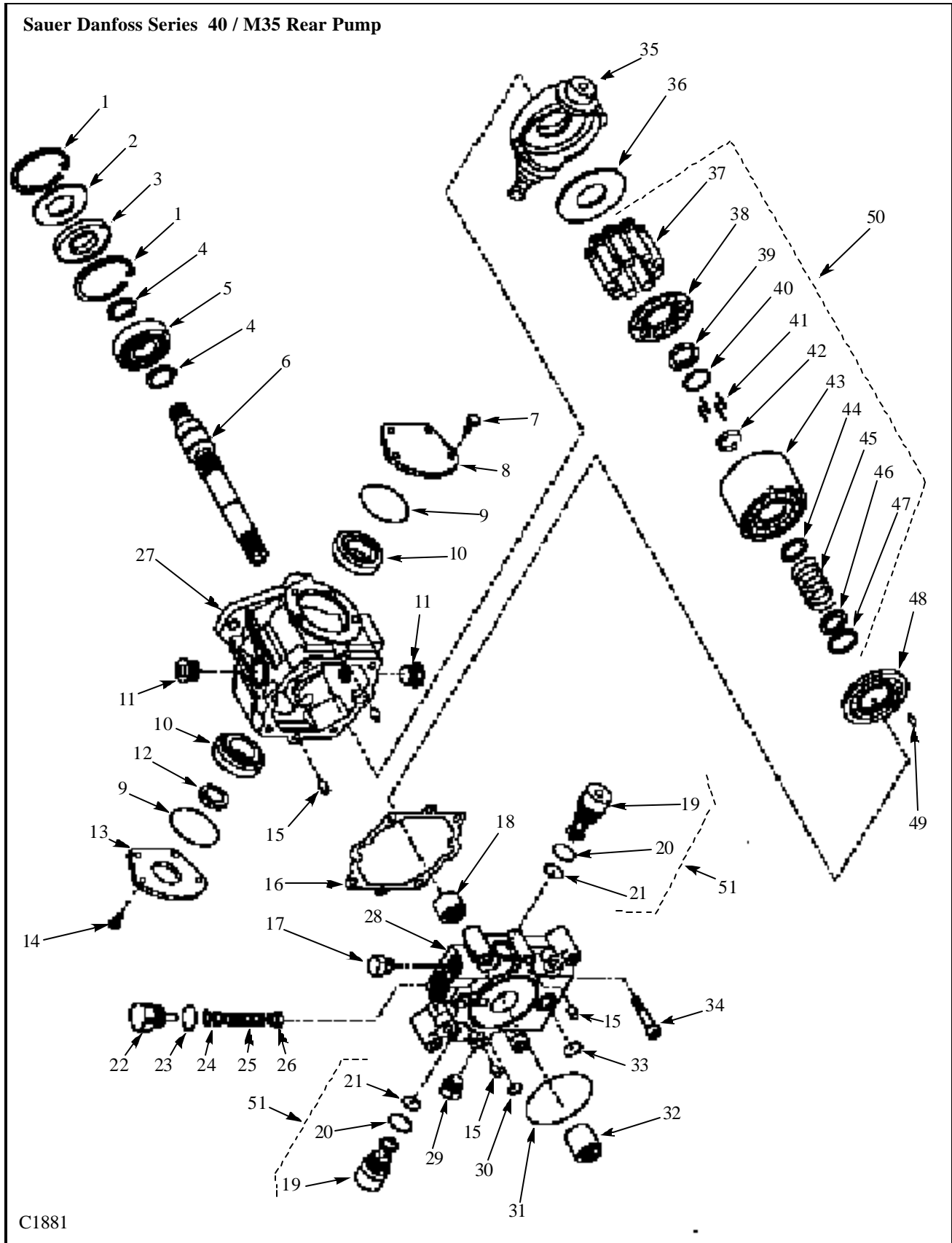

2

C1881

# — TANDEM PUMP PARTS DIAGRAM 2.11 —

## Rear Pump Diagram C1881 Index

2

1. Retaining ring
2. Seal support washer
3. Input seal
4. Retaining ring
5. Bearing
6. Drive shaft
7. Bolt
8. Cover
9. O-ring seal
10. Bearing
11. Plug
12. Swashplate seal
13. Swashplate cover
14. Bolt
15. Dowel pin
16. Gasket
17. Plug
18. Bearing
19. Relief valve
20. O-ring seal
21. O-ring seal
22. Charge relief plug
23. O-ring seal
24. Charge relief shims
25. Charge relief spring
26. Charge relief poppet
27. Pump housing
28. End cap
29. Plug
30. O-ring seal
31. O-ring seal
32. Coupler
33. O-ring seal
34. Screw
35. Swashplate
36. Thrust plate
37. Piston assembly
38. Slipper retainer
39. Slipper retainer guide
40. Special washer
41. Slipper hold down pins
42. Hold down pin retainer
43. Cylinder block
44. Washer
45. Spring
46. Washer
47. Retaining ring
48. Valve plate
49. Spring pin
50. Cylinder block kit
51. Relief valve kit

**For further service instructions refer to a Sauer Danfoss Dealer and request Service / Repair Manual Part Number BLN 9992, or order P / N 44232 from a local Thomas Dealer.**

# TANDEM PUMP PARTS DIAGRAM 2.11

Sauer Danfoss Series 40 / M35 Front Pump

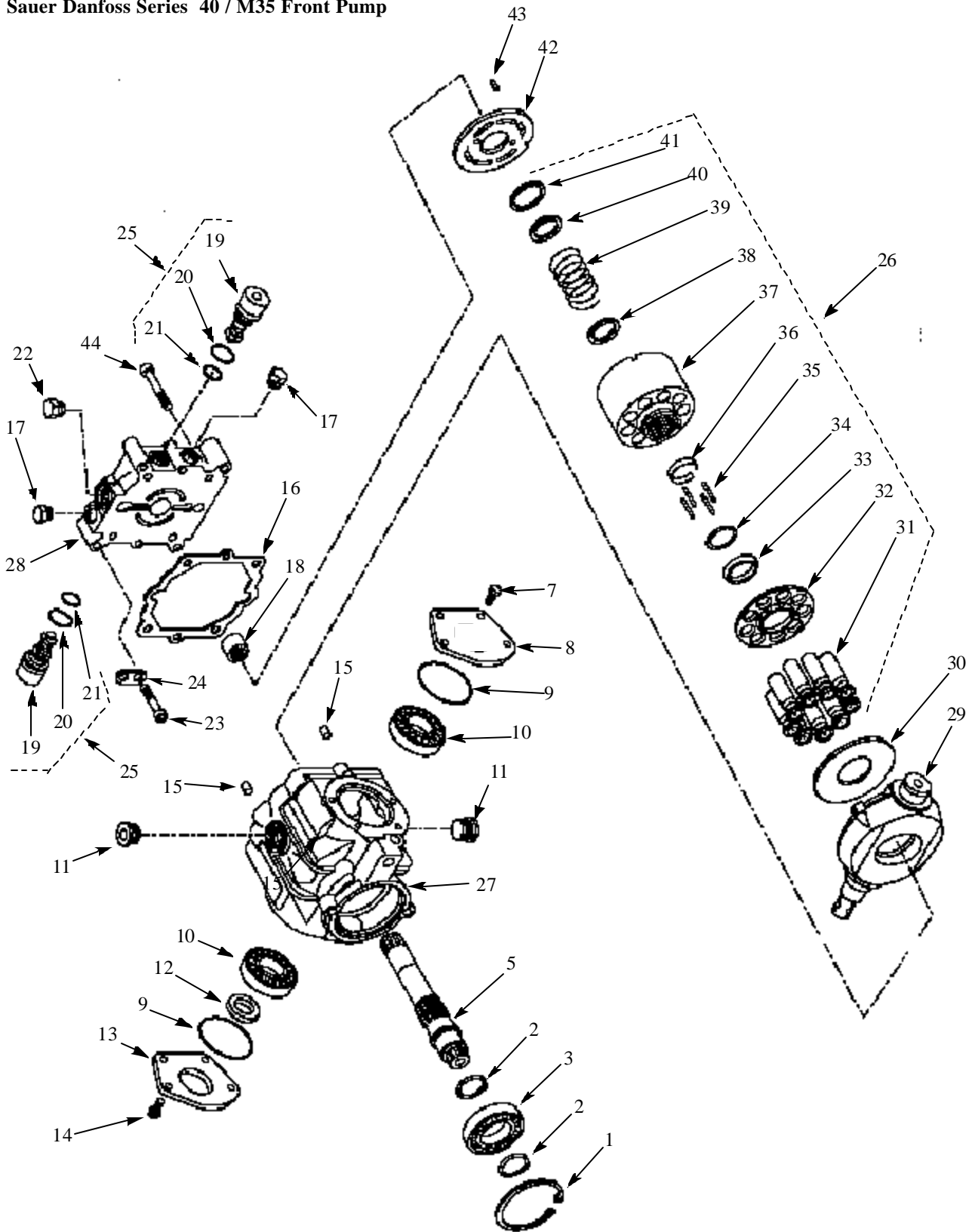

2

C2007

# TANDEM PUMP PARTS DIAGRAM 2.11

---

## Front Pump Diagram C2007 Index

2

1. Retaining ring
2. Seal support washer
3. Input seal
4. Retaining ring
5. Bearing
6. Drive shaft
7. Bolt
8. Cover
9. O-ring seal
10. Bearing
11. Plug
12. Swashplate seal
13. Swashplate cover
14. Bolt
15. Dowel pin
16. Gasket
17. Plug
18. Bearing
19. Relief valve
20. O-ring seal
21. O-ring seal
22. Plug
23. Screw
24. Bracket
25. Relief valve kit
26. Cylinder block kit
27. Pump housing
28. End cap
29. Swashplate
30. Thrust plate
31. Piston assembly
32. Slipper retainer
33. Slipper retainer guide
34. Special washer
35. Slipper hold down pins
36. Hold down pin retainer
37. Cylinder block
38. Washer
39. Spring
40. Washer
41. Retaining ring
42. Valve plate
43. Spring pin

**For further service instructions refer to a Sauer Danfoss Dealer and request Service / Repair Manual Part Number BLN 9992, or order P / N 44232 from a local Thomas Dealer.**

# TANDEM PUMP PARTS DIAGRAM 2.11

LN000500 onward shown

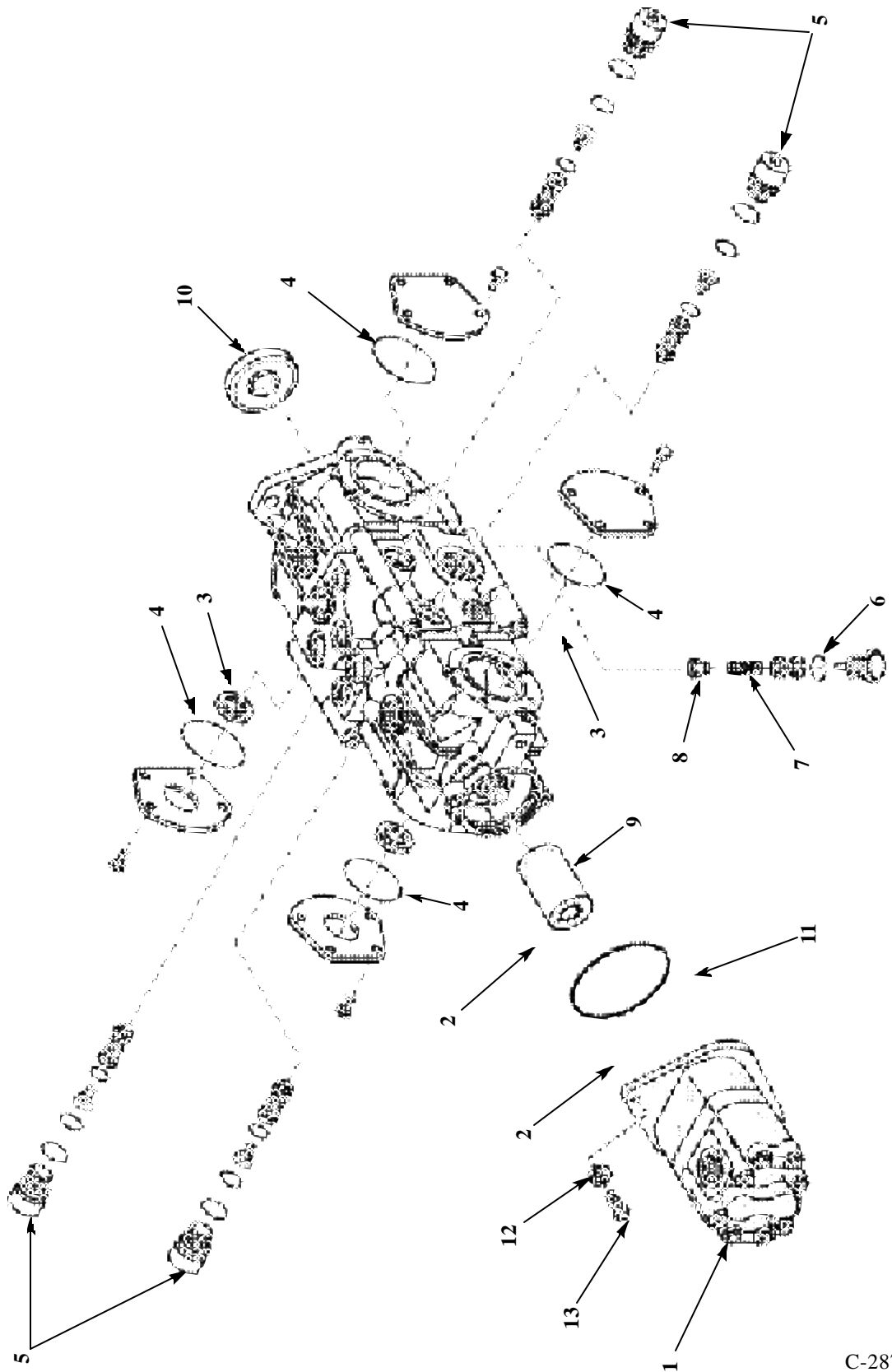

2

C-2875

# TANDEM PUMP PARTS DIAGRAM 2.11

---

## Pump Diagram C2875 Index

2

- Tandem Pump Assy, Complete
- Tandem Pump Assy, Complete (SN LN000500 onward)
- Tandem Pump Assy, No Gear Pump
- Tandem Pump Assy (345 Bar Relief Setting) (LE009196 onward), No Gear Pump (LN000101 onward)
- 1 Tandem Pump Assy (345 Bar Relief Setting) (LN000500 onward)
- 1 Gear Pump (Up to LE009195) Sunstrand
- 1 Gear Pump (LE009196 onward) (LN000101 onward) Eaton Brand
- 1 Gear Pump (LN000500 onward) Eaton Brand
- 2 O-ring
- 3 Seal, Swashplate housing
- 4 O- ring, Swashplate cover
- 5 Relief Valve (345 Bar Setting) (LE009073 onward) (LN000101 onward)
- 6 O-ring, Charge Relief Valve
- 7 Spring, Charge Relief Valve
- 8 Poppet Valve, Charge Relief Valve
- 9 Coupler, Gear pump
- 10 Seal, Input Drive
- 11 Spacer
- 12 Bolt
- 13 Washer, Flat

**For further service instructions refer to a Sauer Sundstrand Dealer and request Service / Repair Manual Part Number BLN 9992, or order P / N 44232 from a local Thomas Dealer.**

# DRIVE MOTOR 2.12

## General Information

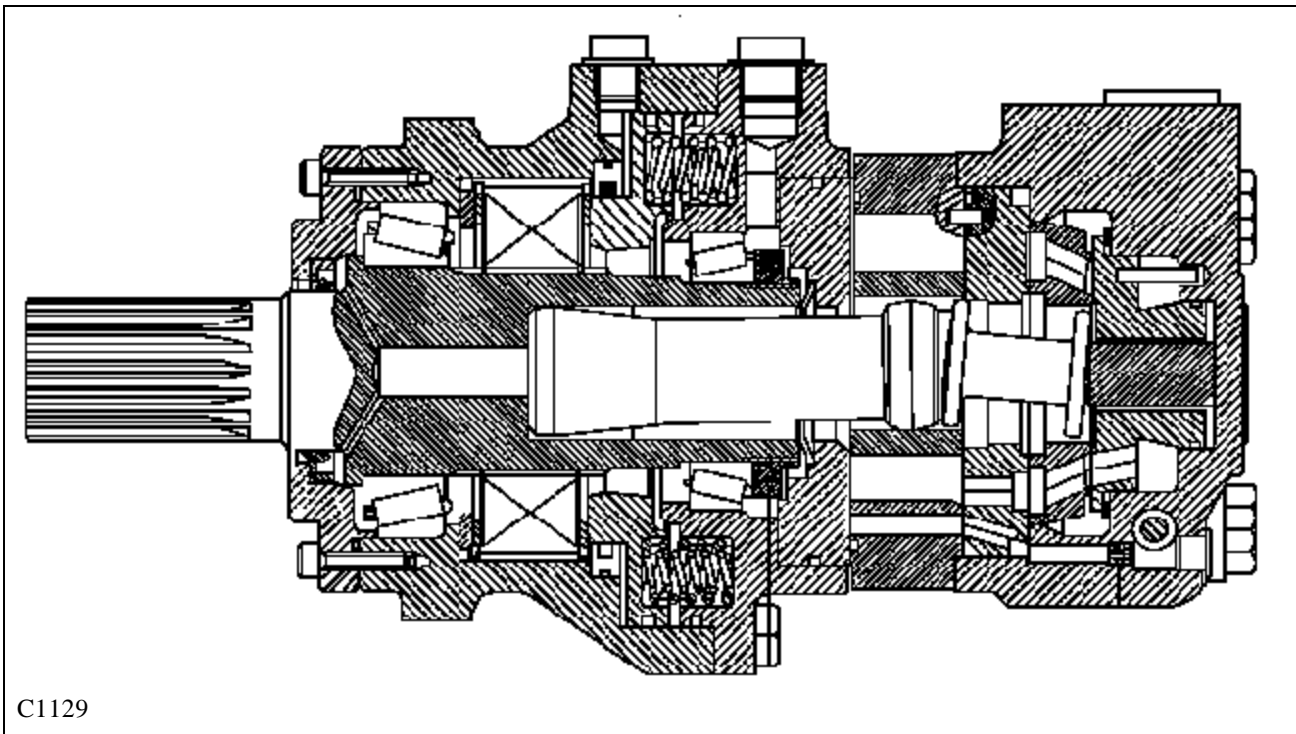

C1129

2

The basic gerotor design uses a combination of mechanical and hydraulic principles that are utilized in the high torque, low speed motors.

The outer ring ( fig. C153 ) of the gerotor assembly is similar to an internal gear that is held in a fixed position by securing it to the motor housing. The rotating inner gear, called a star, orbits inside the secured outer ring.

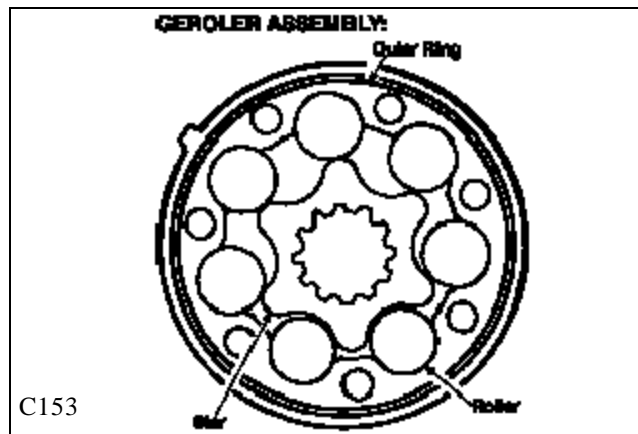

C153

Because of the different number of teeth on the star and outer ring, the star rotates in an eccentric circular orbiting motion from the housing center line. ( fig. C154 )

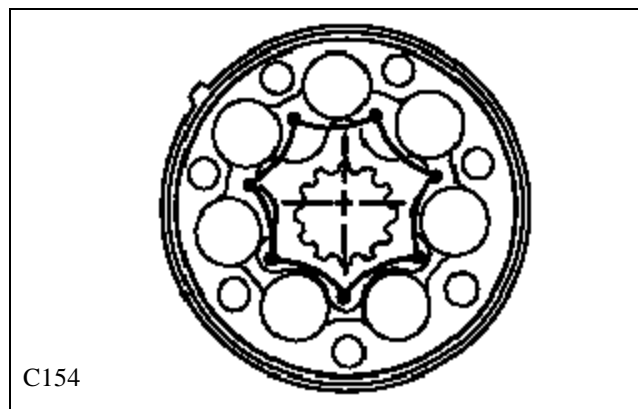

C154



## DRIVE MOTOR 2.12

A drive shaft is used to transmit the rotation of the star to the output shaft. The drive shaft has crowned external splines to match the internal splines in the star and output shaft. This type of drive is used because the star center line continuously changes during rotation.

2

As the star orbits, it causes a continuous opening and closing of the outer ring fluid pockets. Half of these fluid pockets are subject to fluid pressure, causing star rotation, and the opposing half are connected to the return line.

When pressure is introduced into the fluid pockets on the right side of the star ( fig. C156 ) the output rotation will be counterclockwise. When the fluid pockets on the left side of the star are pressurized the output shaft rotation will be clockwise.

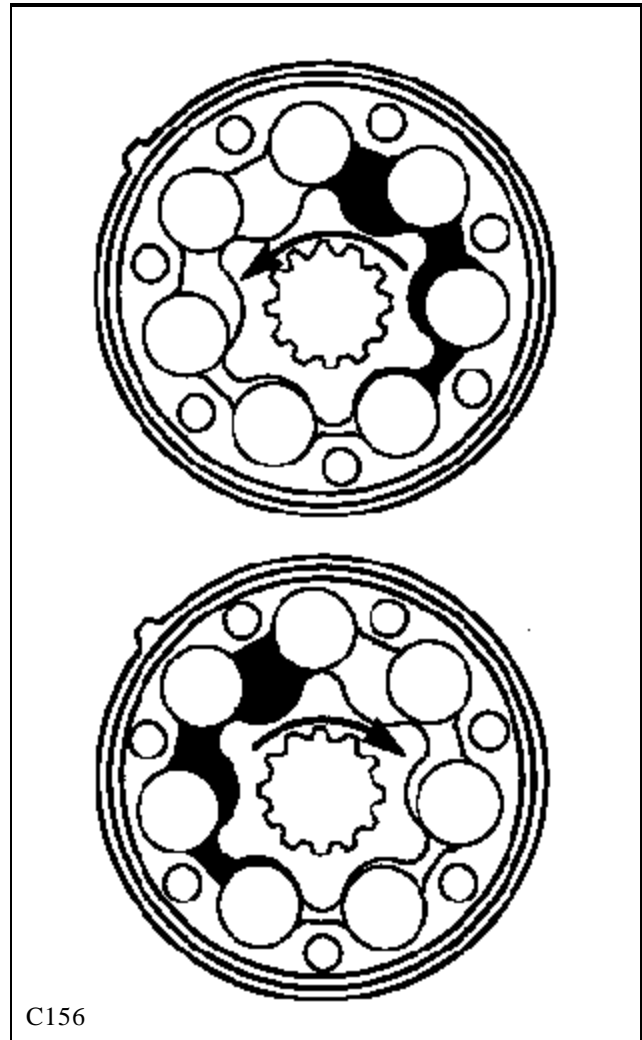

To seal the fluid pockets the torque motor incorporates a rotating roller type seal. ( fig. C157 ) This type of a rolling seal reduces friction at the star points providing increased efficiency and reduced component wear.

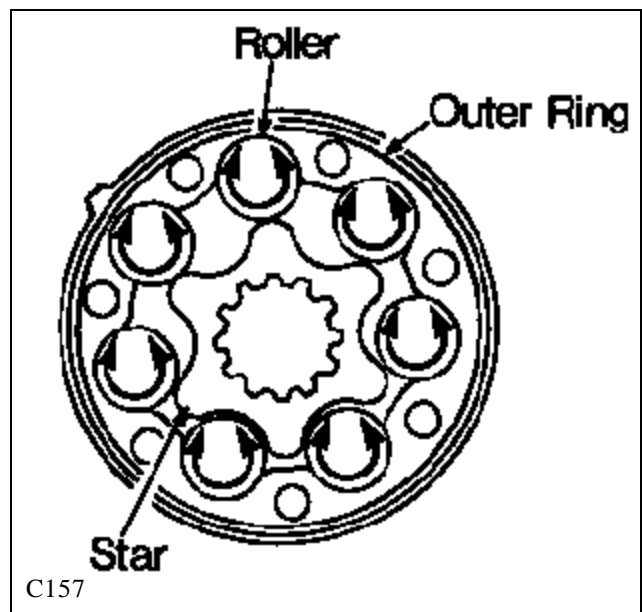

## DRIVE MOTOR 2.12

The geroler (fig. C2299), is both a fluid displacement motor and a gear reducer. It provides 8 times (the number of star points) greater power per revolution than a gear, vane or piston type motor. This means that 8 times the greater torque can be developed at one eighth the speed without further gear reduction.

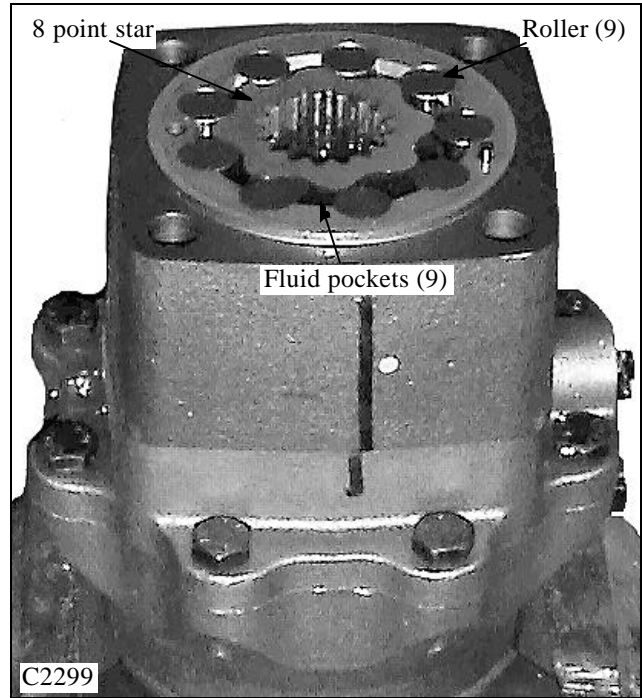

Example shown in fig. C166 is one complete star orbit, or one sixth of the output shaft rotation. The star must travel through 6 complete orbits for each single rotation of the output shaft creating a speed reduction of 6 to 1. The use of 7 fluid power pockets with the 6 to 1 ratio provides 42 fluid power cycles per each complete shaft revolution. **NOTE: Actual star point count is 8. This is only an example.**

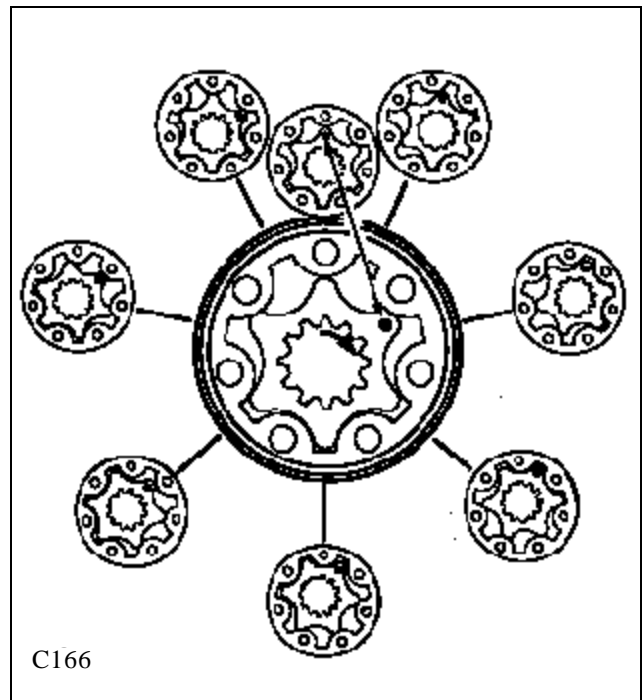

## DRIVE MOTOR 2.12

For smooth and continuous motor output rotation, the torque motor utilizes a disc valve which operates in synchronization with the geroler star. The disc valve arrangement consist of a stationary balance plate, rotating disc valve and a stationary valve plate.

The disc valve contains an inlet fluid passage port for each star valley and a return fluid passage point.

A separate crowned driveshaft is used to synchronize the disc valve and the geroler star so that they turn as one. To accept fluid from the disc valve, the valve plate also contains internal porting passages to each outer ring pocket area.

2

C1891

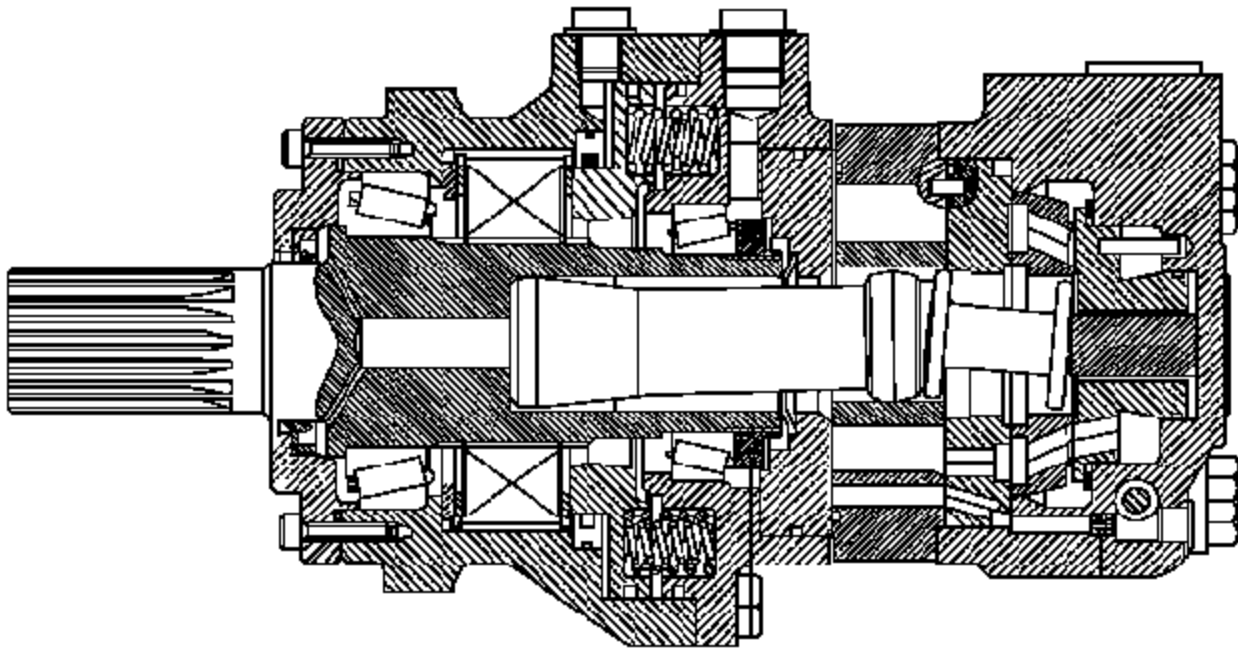
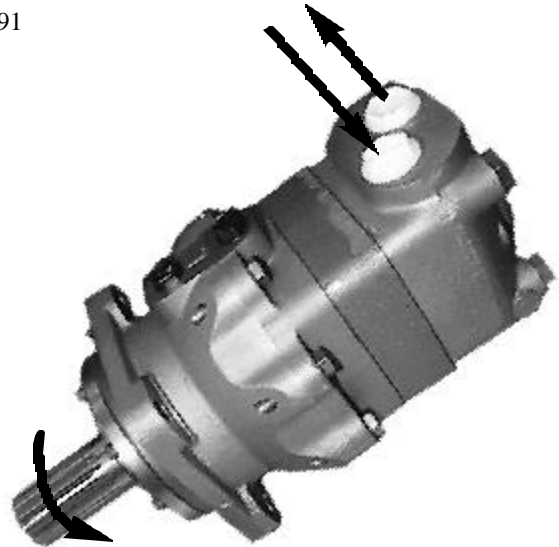

C1129

Fluid enters the housing through the inlet port and is directed to the balance plate. The balance ring contains an inner and outer seal to separate the high and low pressure fluid passages. Fluid passes through the stationary balance plate to the rotating disc valve. The rotating disc valve ports the fluid to the stationary valve plate and the proper side of the geroler pockets causing the rotor star to turn.

As the rotor star rotates, and each fluid pocket reaches its full open position, the return porting in the rotating disc

valve opens to allow the fluid in the pocket are to pass back through the valve plate, disc valve, balance plate and out through the housing return port, as the pocket closes.

The disc valve is timed to the geroler rotor star to govern the the inlet fluid flow to the output shaft rotation. If the timing of the disc valve to the geroler star is off one tooth, the relationship of input fluid flow to output motor shaft rotation will be reversed.

# DRIVE MOTOR 2.12

## Removal

1 Remove any attachment, raise the boom arms and engage the boom support pins.



### WARNING

To prevent personal injury do not work under the boom arms without the boom supports engaged.

- 2 Raise the loader securely off the ground.
- 3 Remove the wheels on the side to be repaired.
- 4 Drain the oil from the final drive housing. Be prepared to contain approximately 1.9 gal (7 l) of fluid. (fig. C1888)
- 5 Remove the seat and hydrostatic shield.
- 6 Remove the final drive inspection cover located between the axles of the final drive housing.(fig. C2073)
- 7 Disconnect the chain as outlined in Section 3.

8 Remove the 2 high pressure hoses from the drive motor. ( fig. C2074 ) Cap the open hose ends and fittings to prevent contamination.

### IMPORTANT

When making repairs to the hydraulic system, keep the work area and parts clean. Use caps and plugs on all open line and ports.

9 Disconnect the brake line hose and the case drain hose from the drive motor. Cap the hoses and adapter fittings in the drive motor. (fig. C2082)

10 Remove the adapter fittings from the drive motor. Plug the open ports in the drive motor to prevent contamination.

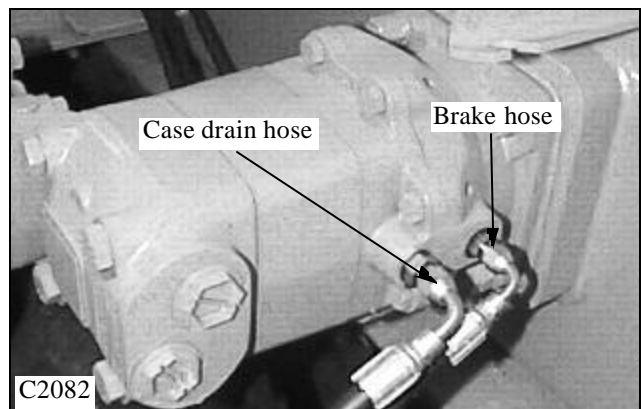
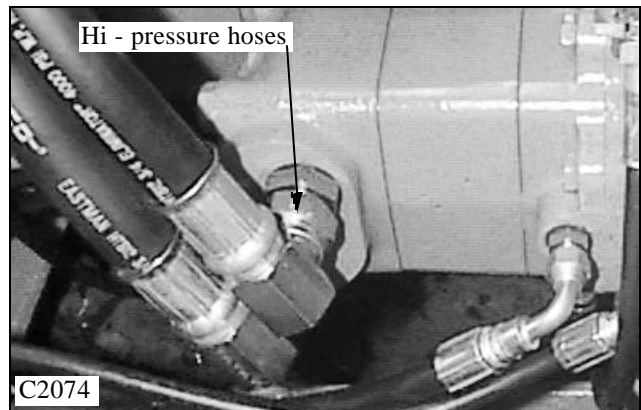
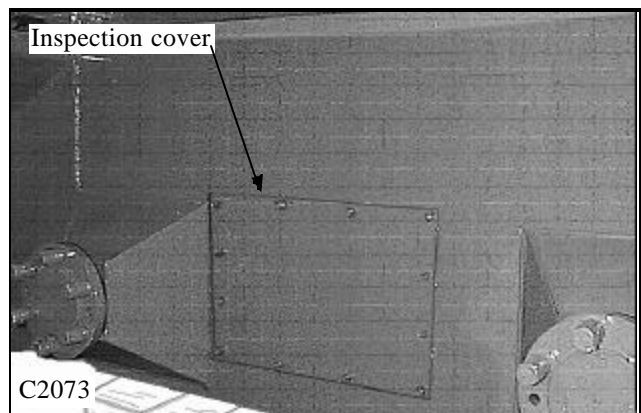
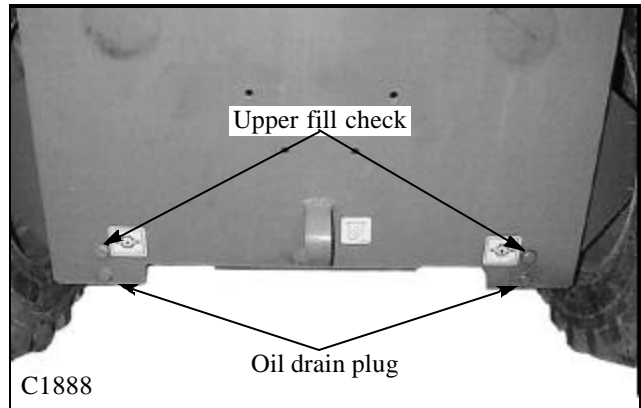

# 2

## DRIVE MOTOR 2.12

### Removal

2

12 Remove the jam nuts, mounting nuts and lock washers from the 4 mounting bolts retaining the drive motor to the final drive housing. (fig. C2081) Hold the head of the bolts from inside the final drive housing. (fig. C2077)

13 Remove the drive motor. Seal the drive motor with silicone upon reassembly.

14 Upon reassembly torque the 4 mounting nuts to 80 ft lbs (110.4 N m).

15 If the drive motor replacement is being performed because of major parts failure, such as geroler damage, the hydraulic system must be checked for contamination and flushed if necessary as outlined in Section 2.7.

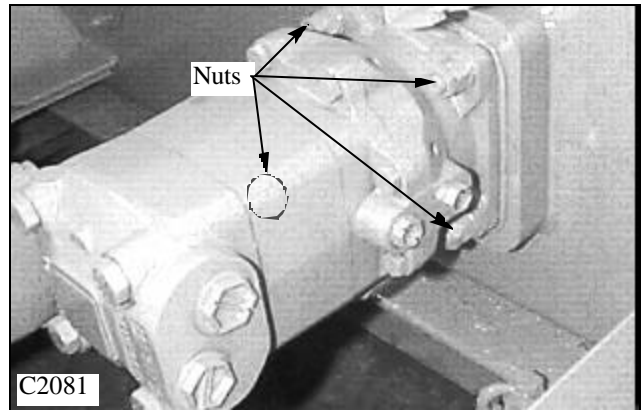

16 Remove the drive motor sprocket and bolt. Visually inspect the drive motor sprocket. Check for worn or damaged teeth on both the outside of the sprocket, and the inside spline (fig. C2079).

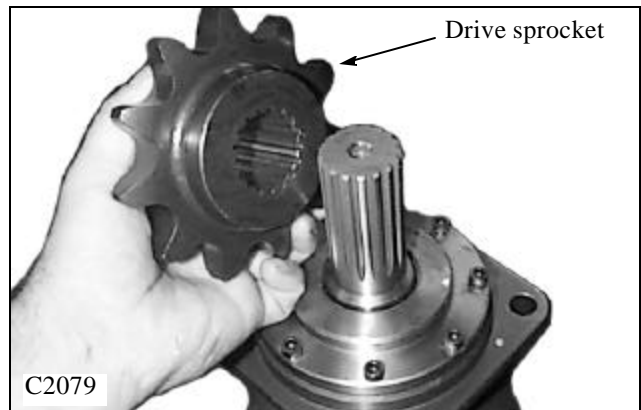

17 Install the sprocket, machined washer, lock washer and bolt. Apply Loctite 242 (blue) to the threads of the bolt before torquing (fig. C2080) and torque the bolt to 25 ft lbs. (34 Nm).



# DRIVE MOTOR 2.12

## Replacement

1 Clean the mounting areas thoroughly that need to be sealed with silicone. (fig. C2078, C2076)

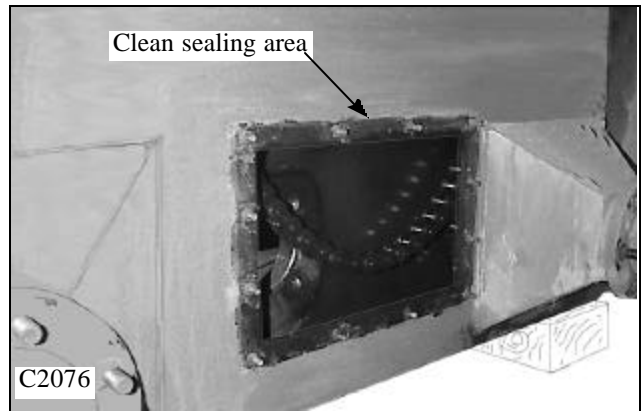
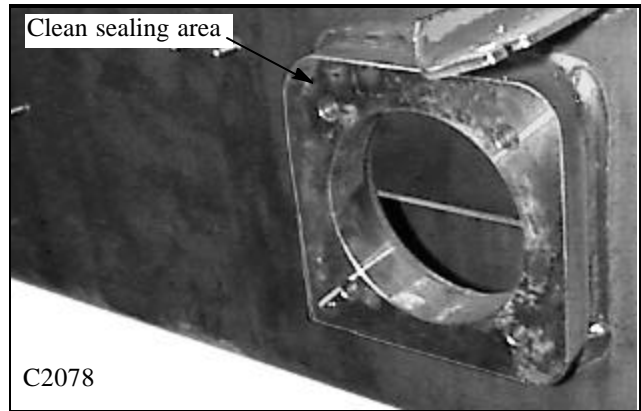

2 Apply a bead 1 / 4 of an inch thick around the drive motor bearing retainer and around each mounting hole. (fig. C2079)

3 Install the drive motor and sprocket assembly to the final drive housing.

4 Install the 4 bolts, lockwashers and mounting nuts and torque to 80 ft lbs (115 Nm.)

5 Install the 4 jam nuts. Torque the jam nuts to 40 ~ 60 ft lbs (54 ~ 81 Nm.)

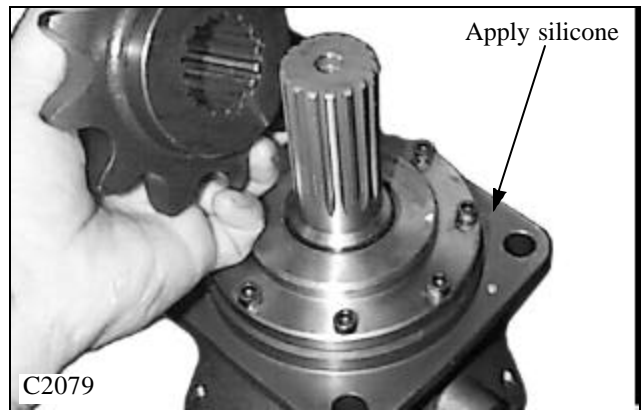

6 Replace the master link in the dive chain. Section 3. shows chain replacement procedure.

7 Add oil to the final drive housing unit it trickles out the upper check plug hole. This will require approximately 1.9 gal (7 litres) of 10w30 API SJ oil. (fig. C1888)

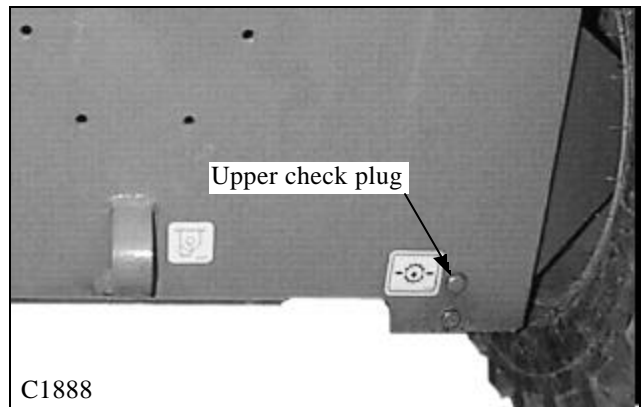

2

# DRIVE MOTOR 2.12

## IMPORTANT

When making repairs to the hydraulic system, keep the work area and parts clean. Use caps and plugs on all open line and ports.

## IMPORTANT

Inspect fitting o-rings and flares for marks or damage. Replace if necessary.

- 8 Install the adapter fittings to the drive motor.
- 9 Install the brake lines to the drive motor. (fig. C2082)



## WARNING

Use caution when dealing with hydraulic fluid under pressure. Escaping fluid under pressure can penetrate the skin and cause serious injury.

- 10 Install the high pressure drive hoses. (fig. C2074)
- 11 Clean the final drive housing and inspection cover thoroughly before sealing the transmission. Apply the gasket Seal to the transmission. (fig. C2076)



## WARNING

To prevent personal injury never make repairs to the hydraulic system while the engine is operating.

- 12 Install the inspection cover. When installing the nuts, do not over tighten. The mounting torque should not exceed 15 lbs ft. (15 Nm)
- 14 Start the engine and check for hydraulic leaks. Do not use your hands to trace hydraulic leaks. Shut off the engine and inspect each fitting for proper torque.
- 15 Install the wheels and torque the nuts at 100 to 110 lbs. (136 to 149 Nm.)
- 16 Install shields and seat, let loader down to ground and test drive to check performance.

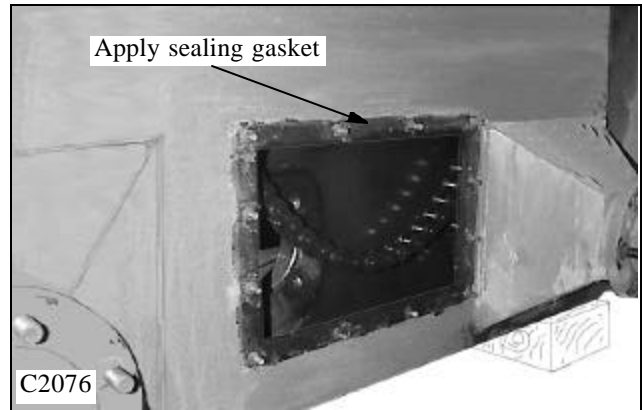

C2076

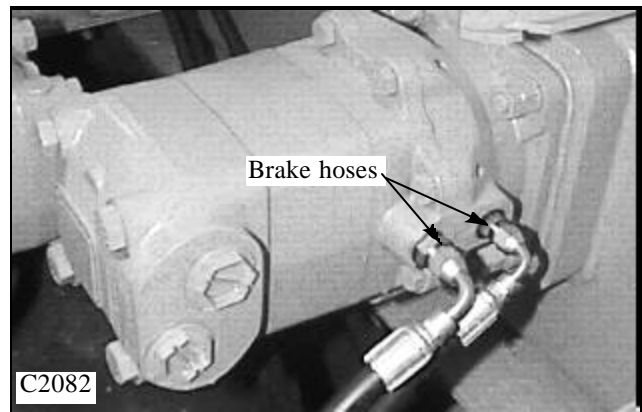

C2082

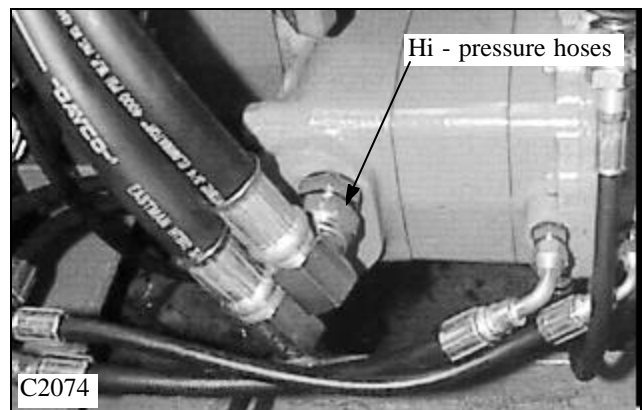

C2074



C1658

# DRIVE MOTOR 2.12

## Parts Illustration

### Danfoss OMT FL Diagram C1892 Index

C1892

1. Name plate
2. Bolts
3. Valve housing
4. Spring washer
5. Spacer
6. O-ring seal
7. O-ring seal
8. Valve drive shaft
9. Channel plate
10. Disc valve
11. Balance plate
12. Guide pin
13. O-ring seal
14. Guide pin
15. Gearwheel set
16. Intermediate plate
17. O-ring seal
18. Conical seal ring
19. Cardan shaft

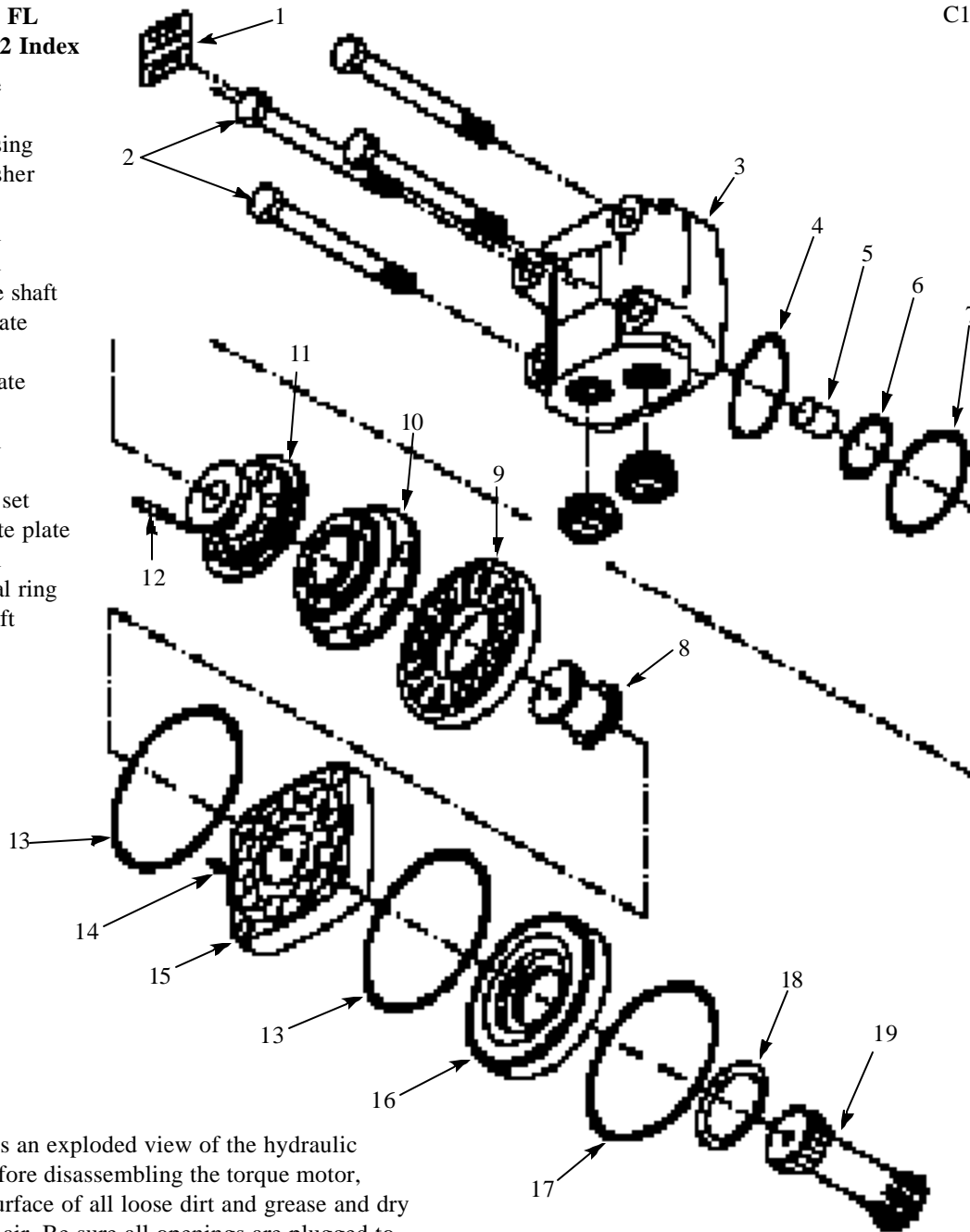

Fig. C1892 shows an exploded view of the hydraulic torque motor. Before disassembling the torque motor, clean the outer surface of all loose dirt and grease and dry with compressed air. Be sure all openings are plugged to prevent solvent or soap entering the torque motor.



### WARNING

To avoid eye injury, use safety goggles when cleaning with compressed air.

### IMPORTANT

When making repairs to the hydraulic system, keep the work area and parts clean. Use caps and plugs on all open line and ports.



# DRIVE MOTOR 2.12

## Parts Illustration

2

### Danfoss OMT FL Brake Diagram C1893 Index

1. Bearing nut
2. Bearing, small
3. Screw
4. Bearing housing
5. O-ring seal
6. Spring
7. Spring
8. Piston
9. O-ring seal
10. Ring
11. O-ring seal
12. O-ring seal
13. Inner brake disc
14. Outer brake disc
15. Spacer disc
16. Bearing housing
17. Bearing
18. Splined shaft
19. O-ring seal
20. Shaft seal
21. Front cover
22. Dust seal ring
23. Screws

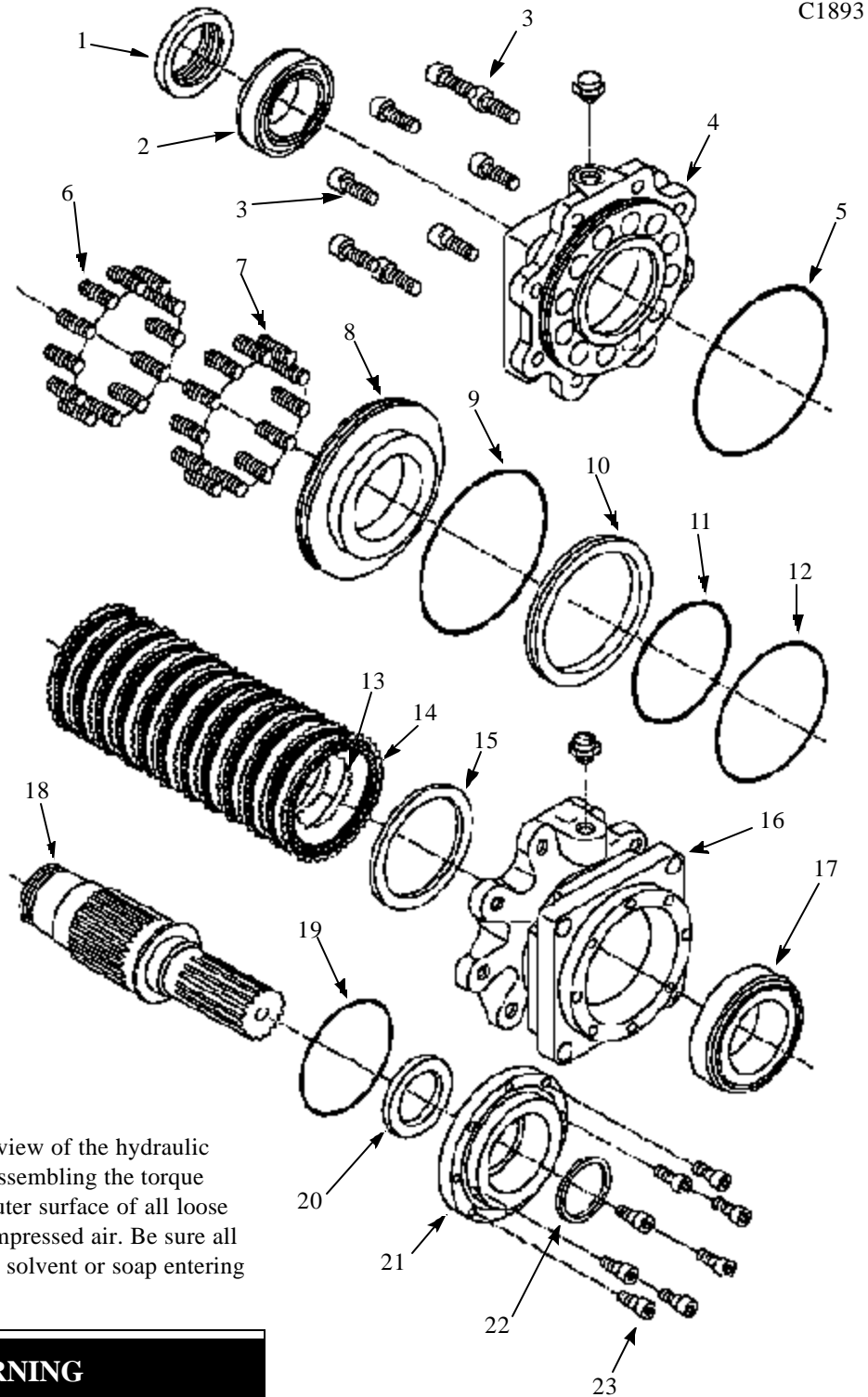

Fig. C1893 shows an exploded view of the hydraulic torque motor brake. Before disassembling the torque motor and or brake, clean the outer surface of all loose dirt and grease and dry with compressed air. Be sure all openings are plugged to prevent solvent or soap entering the torque motor.



### WARNING

To avoid eye injury, use safety goggles when cleaning with compressed air.

# DRIVE MOTOR 2.12

## Disassembly

- 1 Place the drive motor in a vise with the output shaft facing down. Clamp the motor to the vise, holding it by the mounting flange area. Do not clamp the motor on the housing as excessive pressure will cause distortion.
- 2 Mark a line across the various sections of the drive motor to assist in reassembly. (fig. C2287)

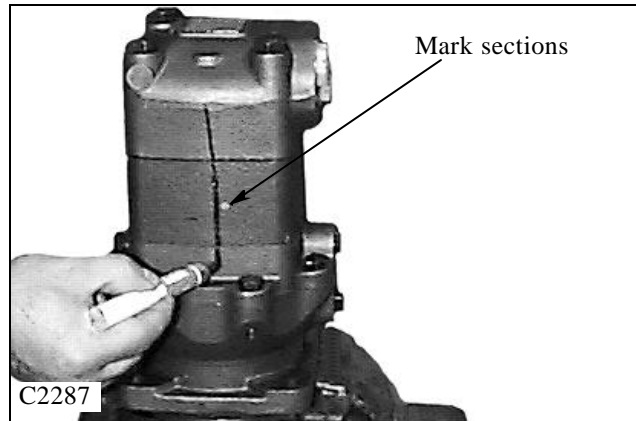

- 3 Remove the small allen head socket plug located between two of the section bolts. (fig. C2288)

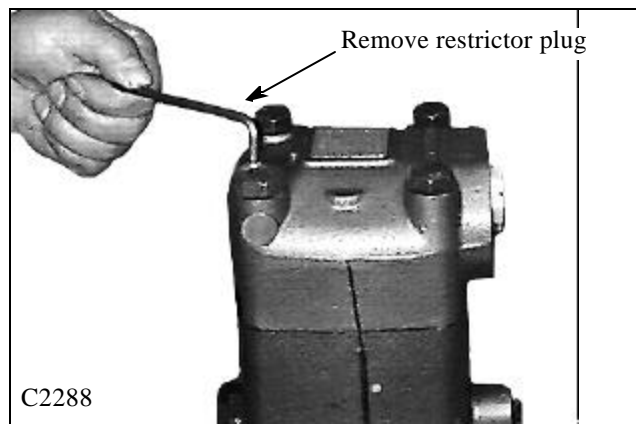

- 4 Insert an allen wrench into the open hole and remove the set screw restrictor. (fig. C2289)

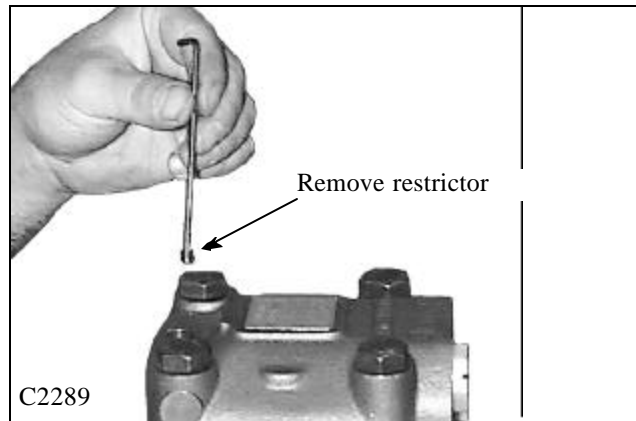

- 5 Remove the 4 bolts from the drive motor valve housing. (fig. C2290) Upon reassembly, torque the bolts in a criss cross pattern at 130 ~ 135 ft lbs. (177 ~ 183.5 Nm)

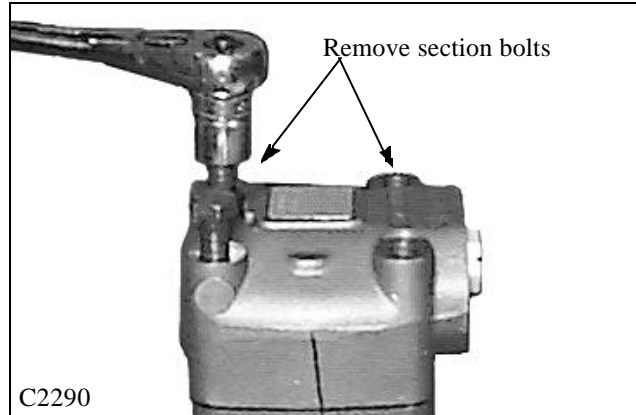

2

## DRIVE MOTOR 2.12

### Disassembly (cont'd)

6 Insert a small screwdriver into the mounting holes of the valve housing assembly and remove the 2 shuttle valve plugs, one each side. (fig. C2291, 2293)

2

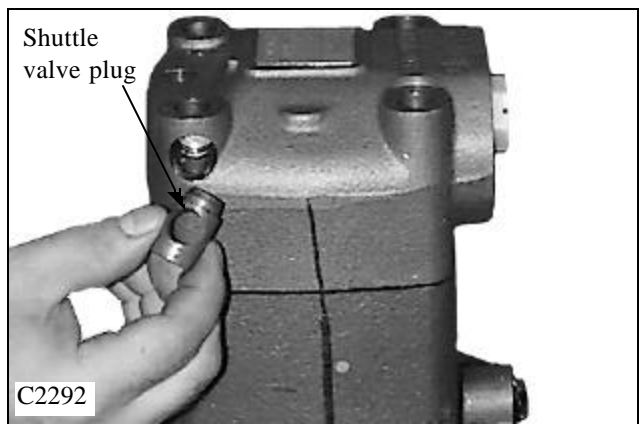
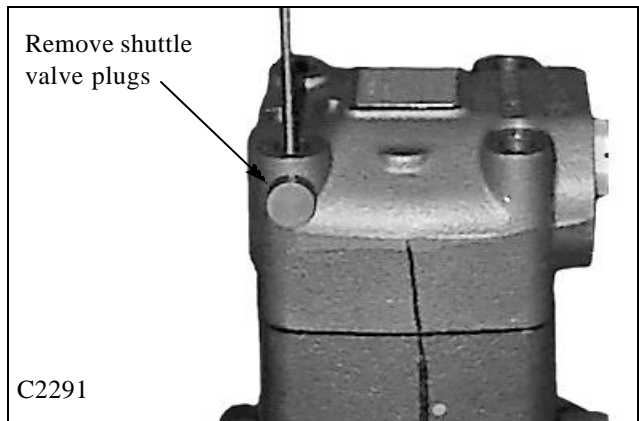

7 Insert a small screwdriver into the shuttle valve plug hole and retrieve the springs. (fig. C2293) There is one on either side.

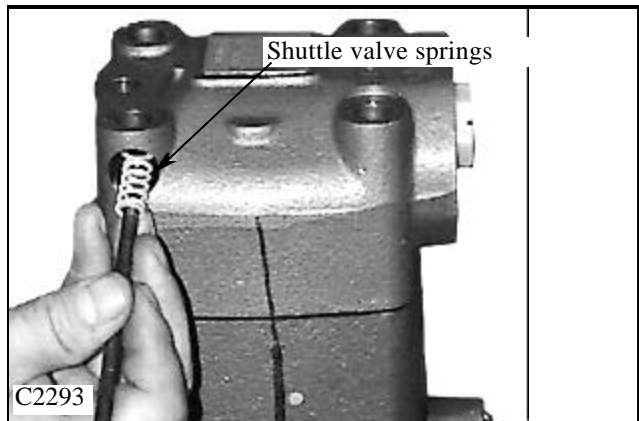

8 Push out the shuttle valve poppet using the screwdriver. (fig. C2294)

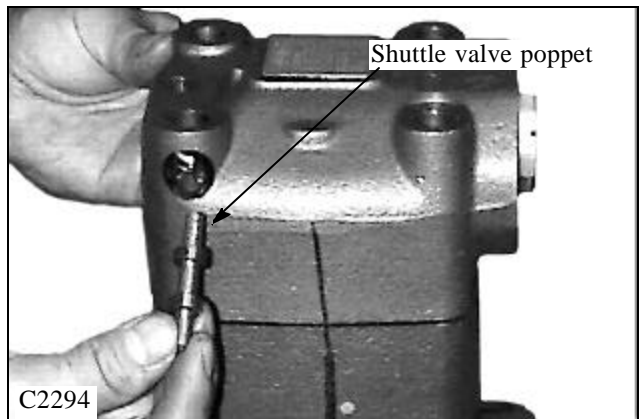

# DRIVE MOTOR 2.12

## Disassembly (cont'd)

9 Carefully lift the valve housing straight up. (fig. C2295) Place your fingers under the valve housing to hold the channel plate in place.

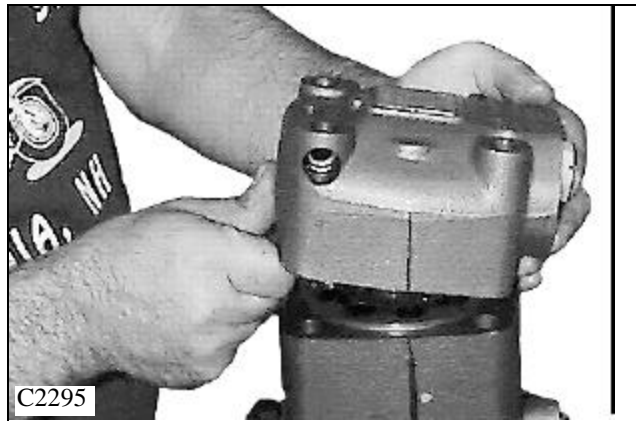

10 Remove the channel plate. (fig. C2296)

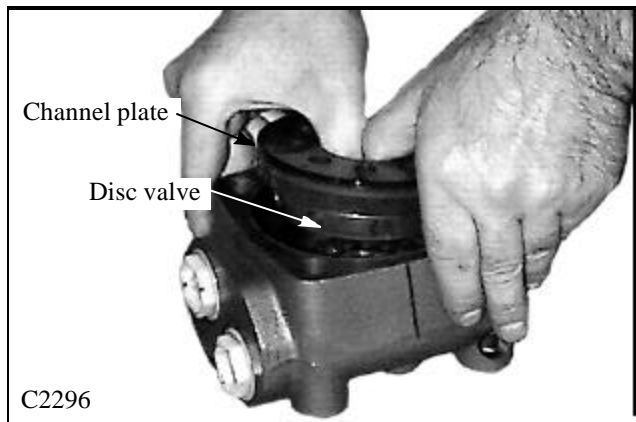

11 Remove the disc valve and balance plate from the valve housing section. (fig. C2297, C2298)

12 Inspect the parts for wear and replace as required. Replace all seals with new when assembling the drive motor.

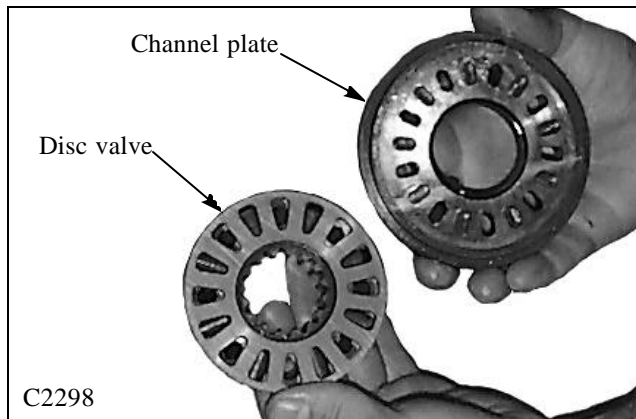
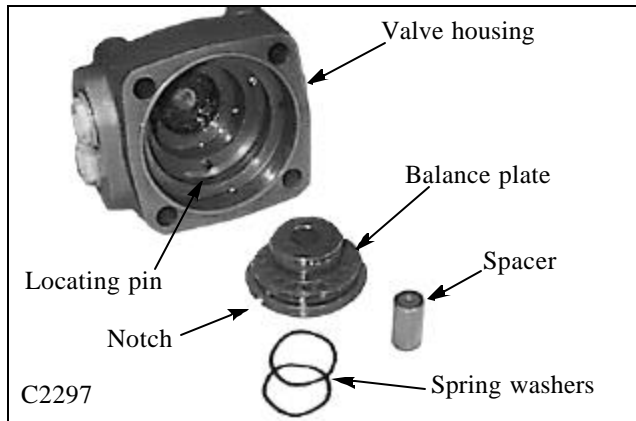

2

## DRIVE MOTOR 2.12

### Disassembly (cont'd)

13 Separate the geroler section from the rest of the motor. (fig. C2300, C2303) Place your fingers between the sections as you lift the geroler section to prevent the rollers and gear from spilling out.

2

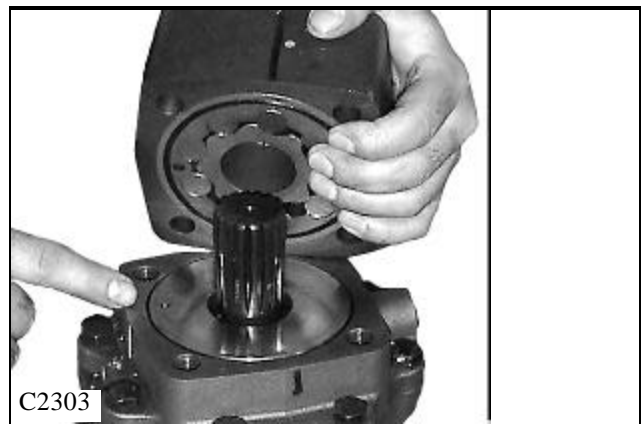
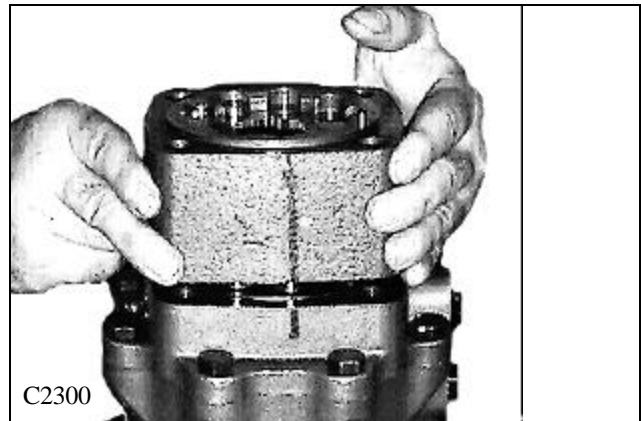

14 Inspect the gears and rollers for wear such as scratches and pitting. (fig. C2301, C2302) Replace worn parts as required. Do not mix the position of the rollers in the geroler section housing.



# DRIVE MOTOR 2.12

## Disassembly (cont'd)

- 15 Remove the cardan (drive) shaft (fig. C2304).
- 16 Remove the intermediate spacer (fig. C2305).
- Replace the seal with new item at time of assembly.

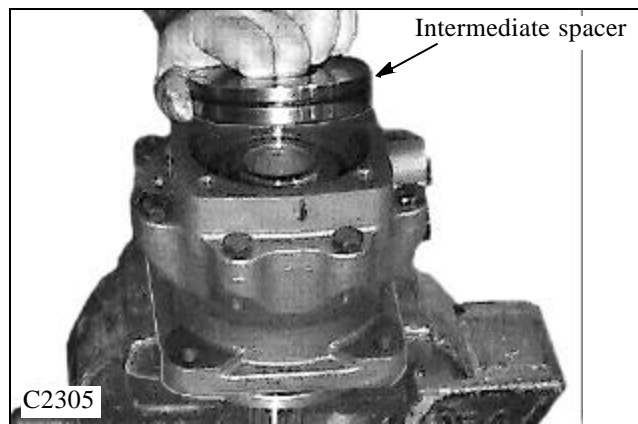
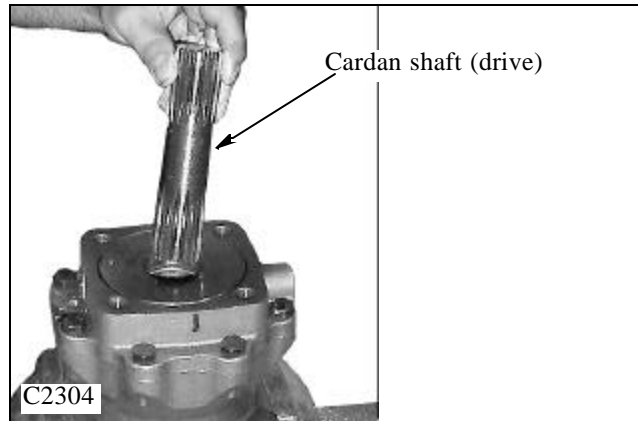

- 17 A special tool will be required as shown in fig. C2306 to remove the bearing nut (fig. C2307). Tool shown was made using 1/2 in. X 1 in. X 3 in. long (12mm x 25mm x 76mm L) material. Two holes were drilled and tap 60mm apart, to accept 6mm X 30mm machine screws.

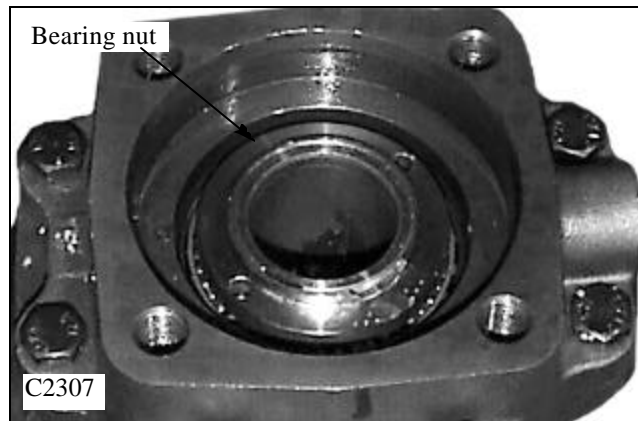
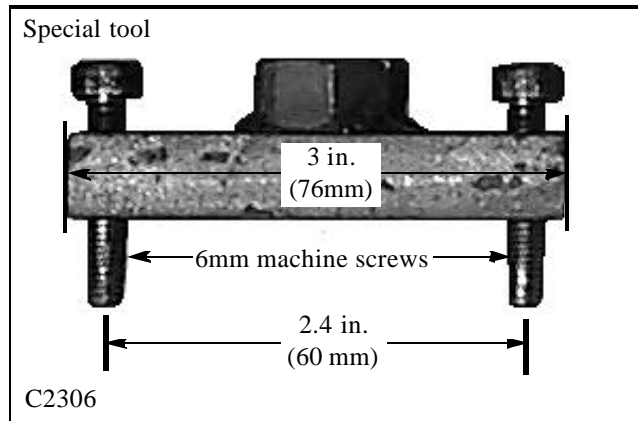

2

# DRIVE MOTOR 2.12

## Disassembly (cont'd)

18 Place the special tool on the bearing nut and remove the bearing nut. (fig. C2308, C2309).

2

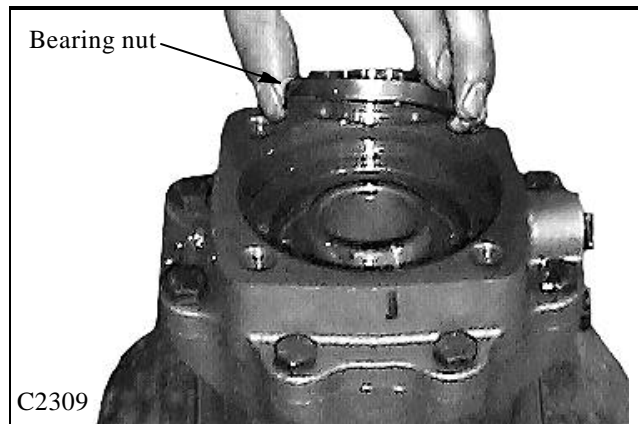
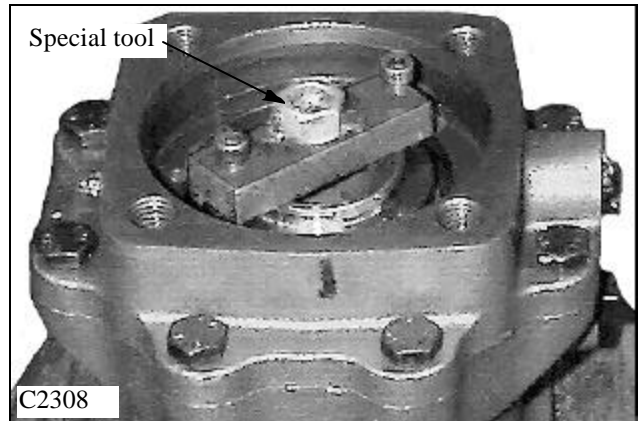

19 Remove the drive motor from the vise and remove the screws retaining the front cover to the bearing housing. (fig. C2310, C2311). Replace the seals with new at time of assembly.

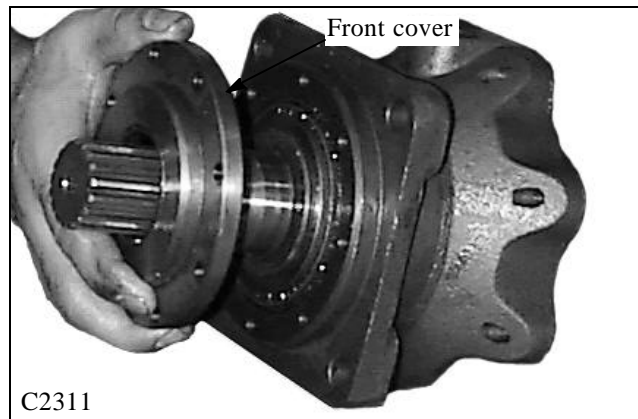
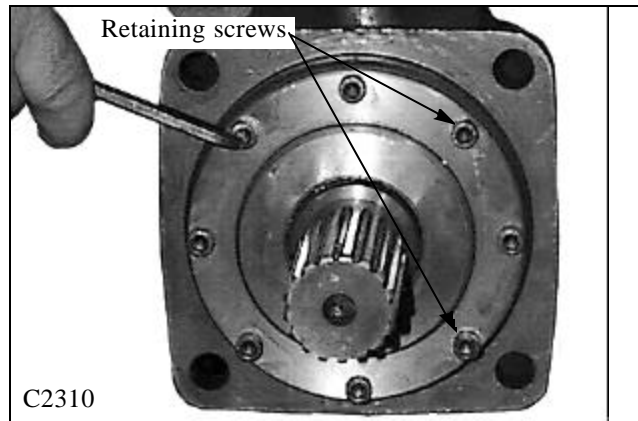

# DRIVE MOTOR 2.12

## Disassembly (cont'd)

20 Use a press and appropriate sized arbor to push the output shaft from the bearings. (fig. C2312).

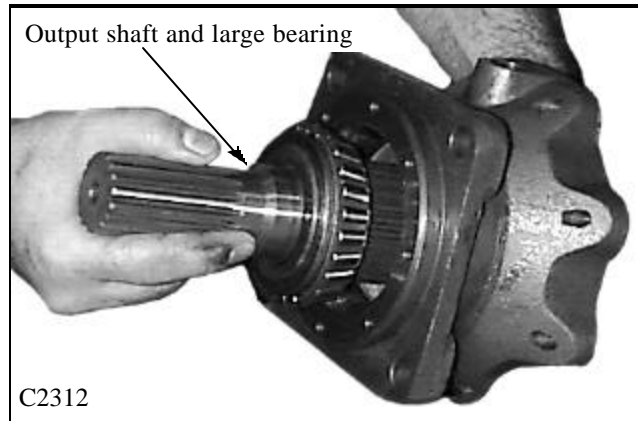

21 Remove the small bearing from the housing. (fig. C2313). Inspect both bearings and races. Replace as required.

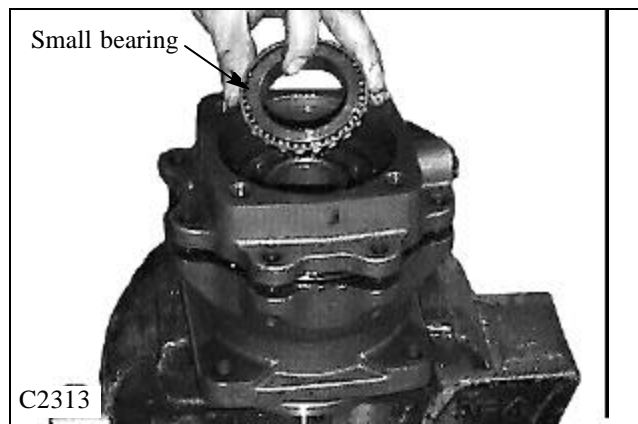

22 Remove the bolts from the around the bearing housing. (fig. C2314).

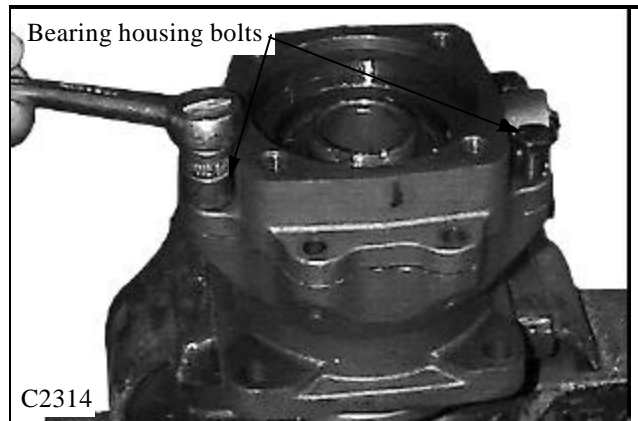

23 Separate the bearing housing sections. (fig. C2315) A mallet may be required to assist removal.

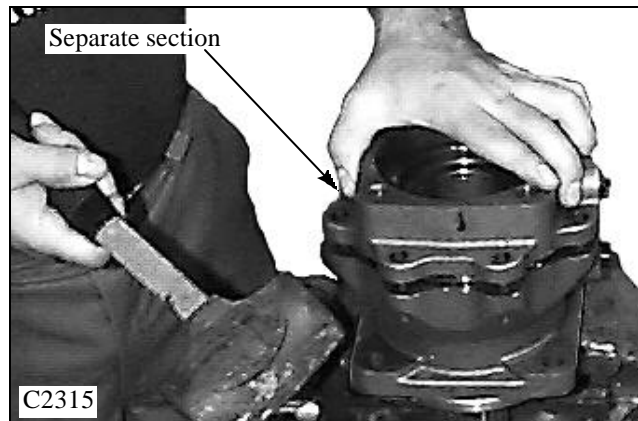

2



# DRIVE MOTOR 2.12

## Disassembly (cont'd)

24 Remove the bearing housing (fig. C2316).

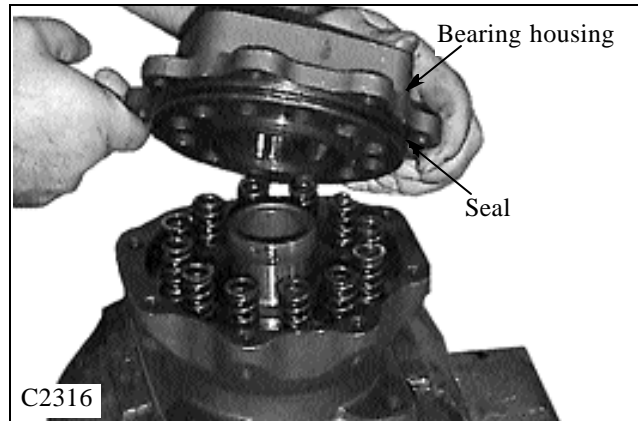

25 Remove the brake springs from the brake piston. (fig. C2317) There are inner and outer springs.

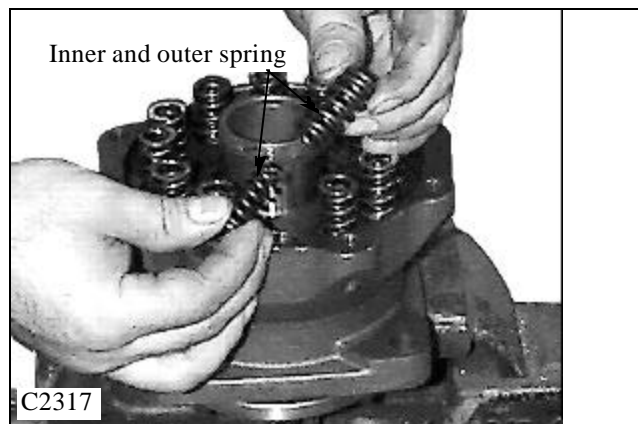

26 Remove the piston from the housing by pushing through from the output shaft side. (fig. C2318)

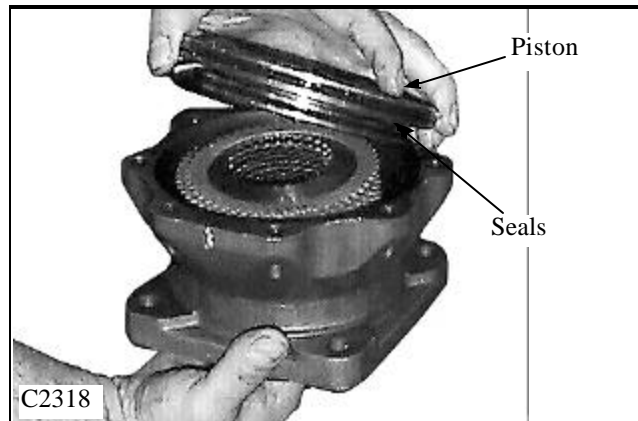

27 Remove the brake disc assemblies. Note the positions of the steel and fibre plates. (fig. C2319). Check the plates for wear and replace as required.

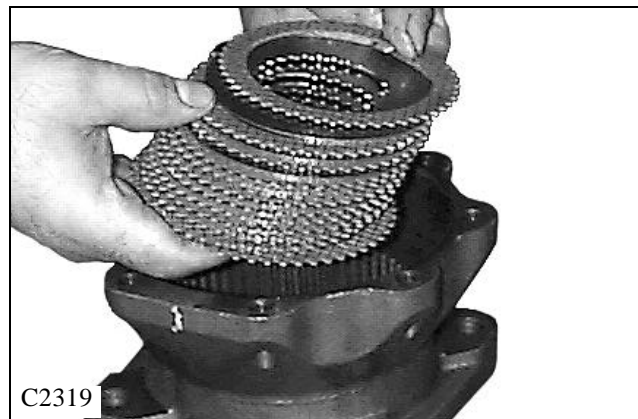

2

# DRIVE MOTOR 2.12

## Assembly

1 Install the output shaft to the housing. (fig. C2321)

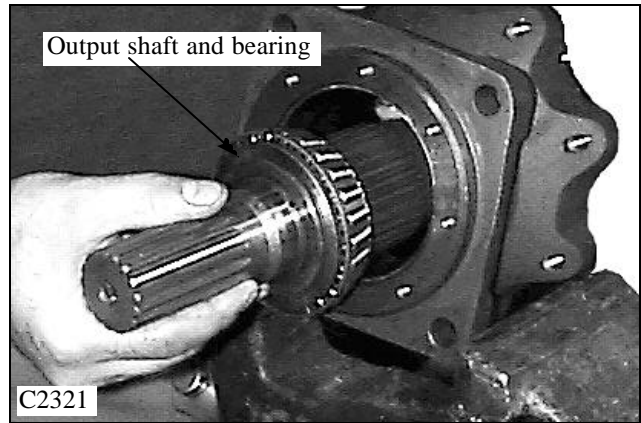

2 Install the front cover to the housing and torque the screws to 8.9 ft lbs (12 Nm). (fig. C2322). Use new seals when assembling the motor.

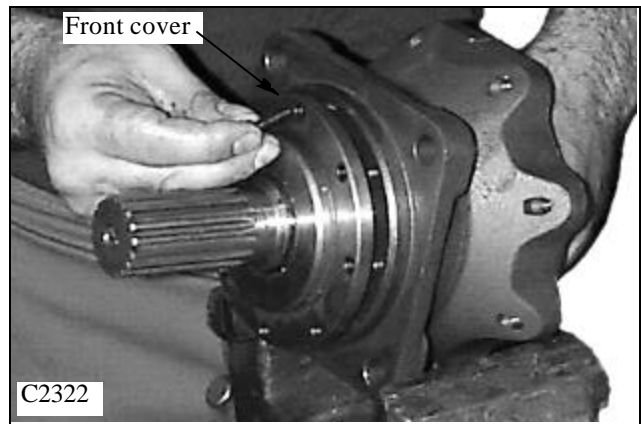

3 Install the brake disc spacer ring to the housing. (fig. C2320)

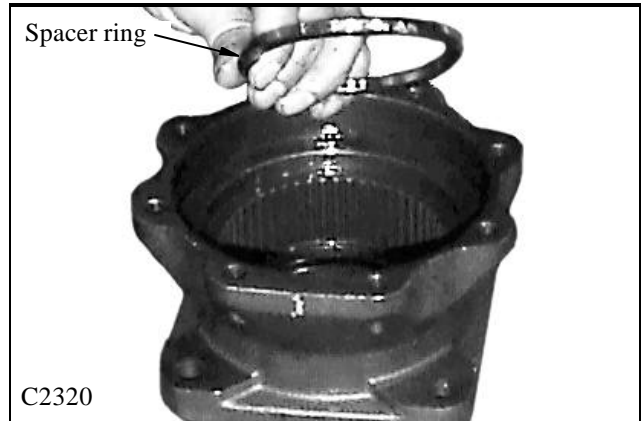

4 Install the brake disc plates. (fig. C2323, C2324, C2319) Start with a fibre plate, add a steel plate, then fibre and so on until the last plate to be installed is a fibre plate.

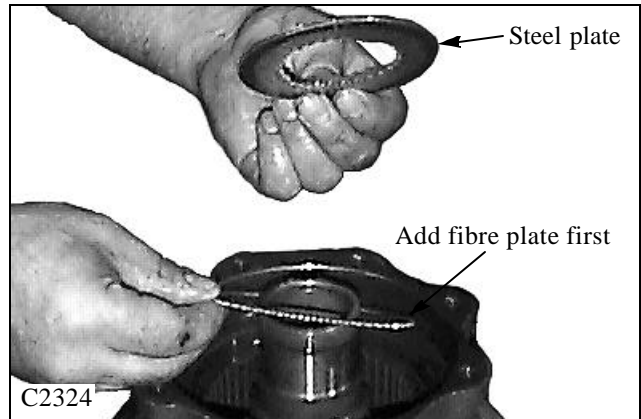

### IMPORTANT

**NOTE:** The fibre plates are also called outer plates due to the “teeth” outside of the plate.

# DRIVE MOTOR 2.12

## Assembly (cont'd)

5 Continue adding plates, 12 fibre, 11 steel plates, to the housing. (fig. C2323, C2319)

2

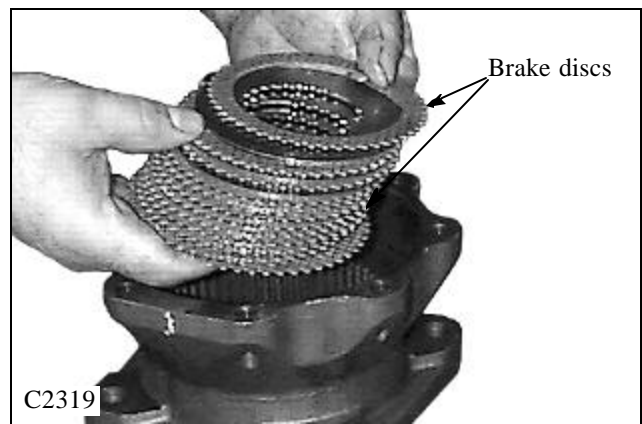
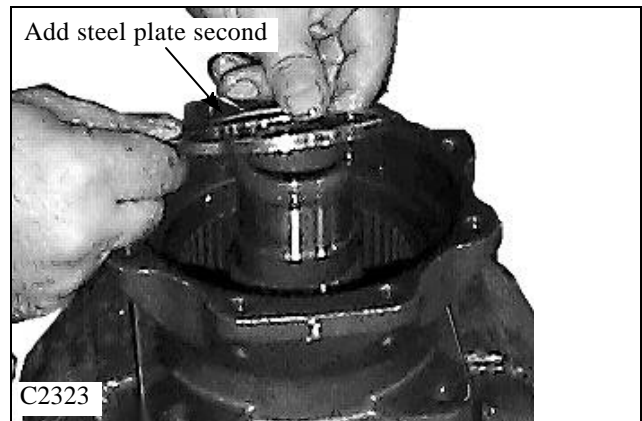

6 Install the piston to the housing, over the brake discs. (fig. C2318) Use new seals when assembling the motor. Align one of the piston spring pockets with the hydraulic inlet port opening in the housing. (fig. C2316)

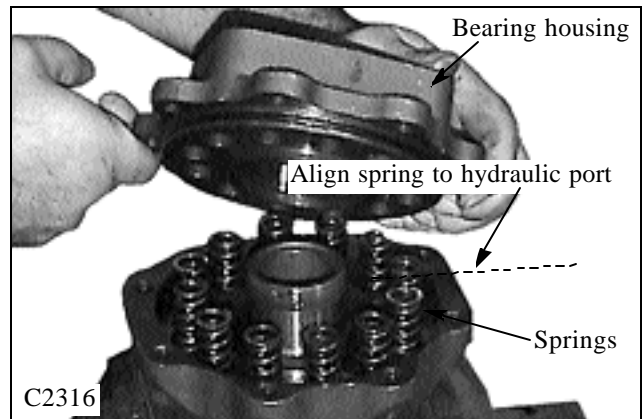
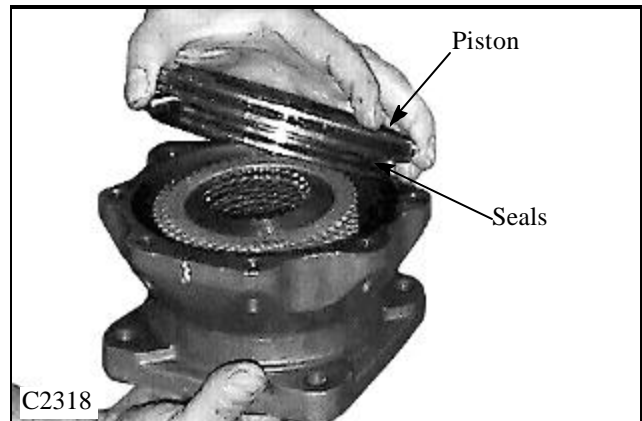

# DRIVE MOTOR 2.12

## Assembly (cont'd)

7 Install the bearing housing bolts and torque to 46.5 ft lbs. +/- 2 ft lbs. (63 Nm +/- 3 Nm) (fig. C2314)

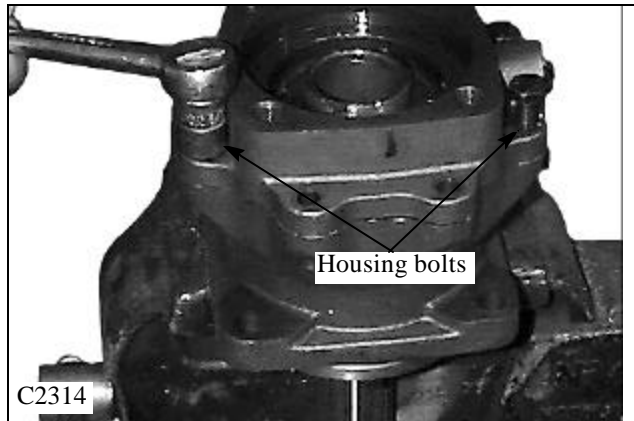

8 Install the small bearing to the output shaft (fig. C2313) in the following sequence:

a. Apply pressure, 175 psi (12 bar), to the brake ports to release the brakes.

b. Press the bearing onto the output shaft with a force of 780 pounds of force (350daN), while rotating the housing back and forth. Be sure to press only on the inner race of the bearing.

c. Remove the brake release pressure before removing the force acting on the bearing.

d. Install the bearing nut and torque to 45 ft lbs. (60 Nm) Strike the nut with blows from a mandrel and hammer to prevent the nut from loosening.

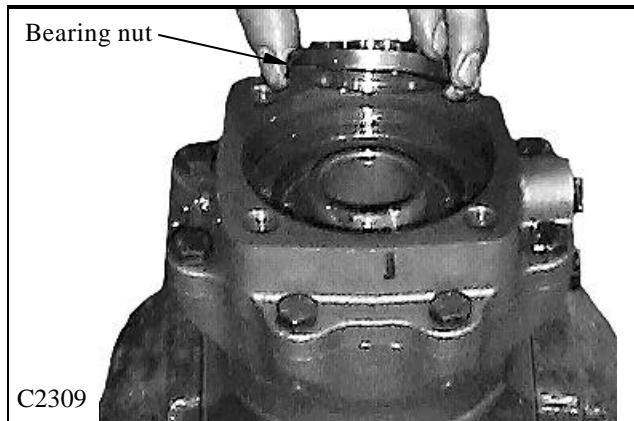
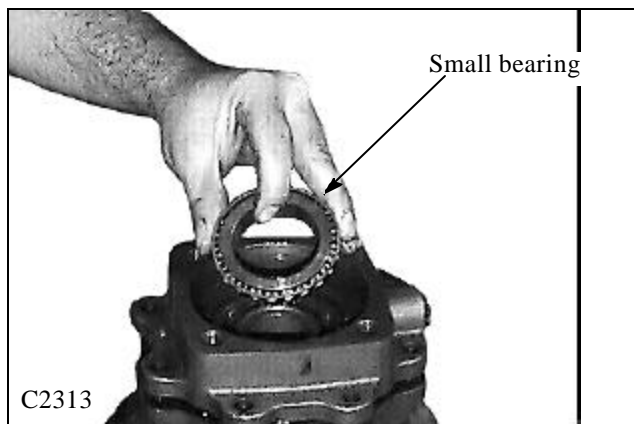

9 Install a new seals to the intermediate plate. (fig. C2325). Apply petroleum jelly to the cup seal to retain in position.



2

# DRIVE MOTOR 2.12

## Assembly (cont'd)

2

10 Install the intermediate plate to the housing. (fig. C2326). Note the alignment pin used to locate the plate to the notch in the housing.

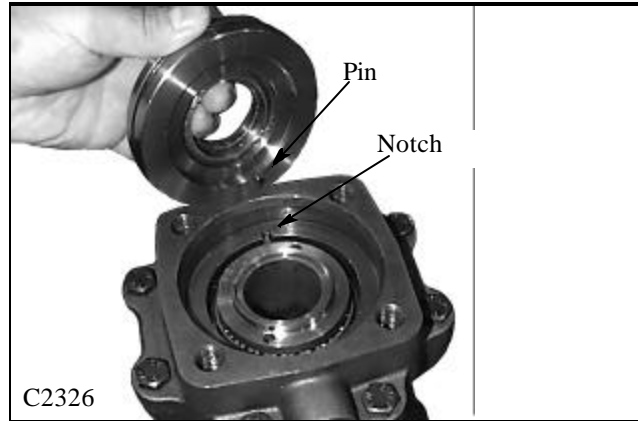

11 Install two studs if available to assist assembly. (fig. C2327).

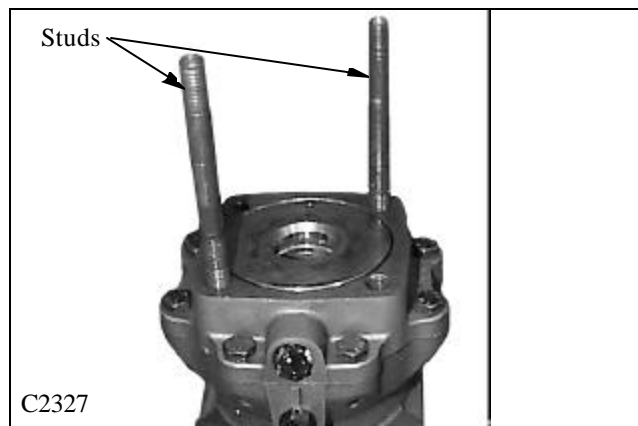

12 Install the cardan (drive) shaft to the output shaft. (fig. C2328).

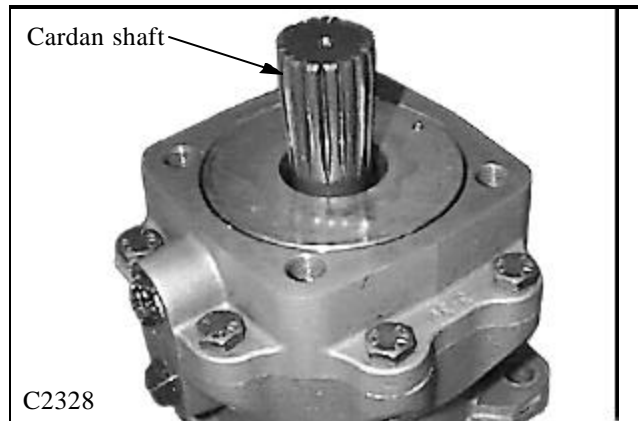

13 Note the holes in the intermediate spacer and the geroler section housing. (fig. C2329). Align these holes when installing the geroler section to the housing.

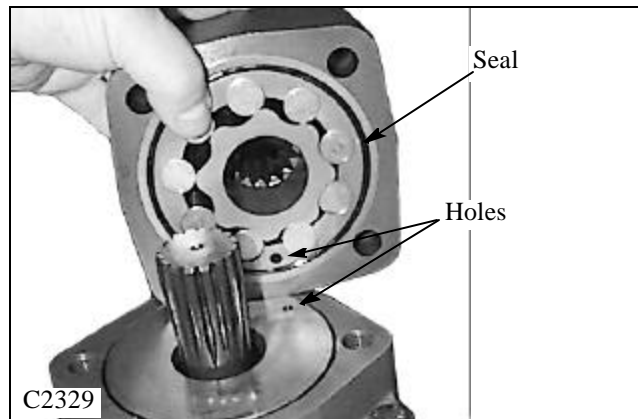

# DRIVE MOTOR 2.12

## Assembly (cont'd)

14 Install the geroler section the housing. (fig. C2330)  
Place a hand under the geroler to prevent the pieces from falling out.

**The following procedures must be followed closely for proper motor rotation.**

15 Mark the gearwheel set rotor at the point where the top of a spline tooth is opposite the bottom of a tooth in the external rotor teeth. (fig. C2331).

16 Mark the bottom of a spline tooth on the valve drive. (fig. C2332).

17 Install the valve drive lining up the marks on the valve drive to the gearwheel set. (fig. C2333).

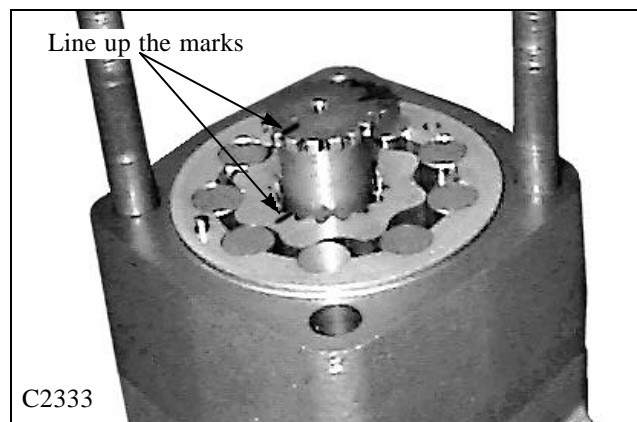
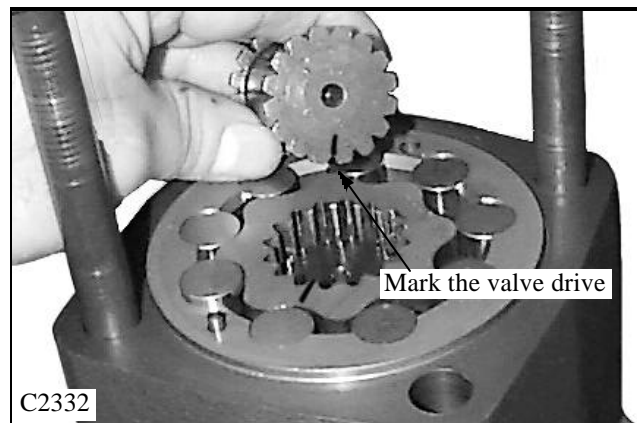
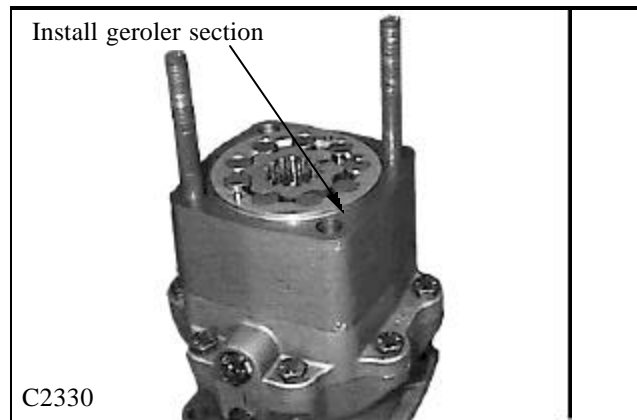

2

# DRIVE MOTOR 2.12

## Assembly (cont'd)

18 Install the channel plate to the geroler section. Install new seals when assembling the motor. (fig.C2334) Note the alignment dowel pin and oil passage hole.

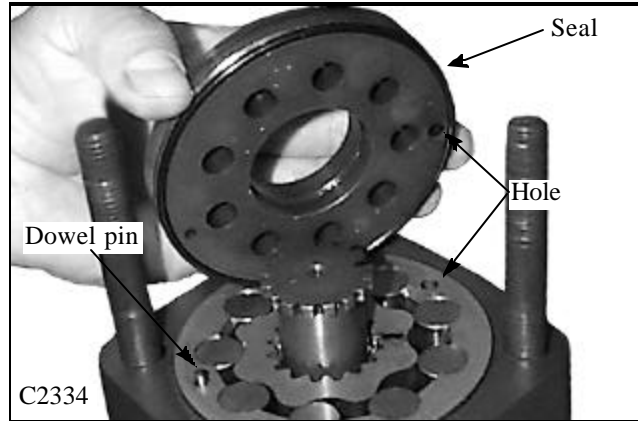

19 Install the disc valve to the valve drive. (fig. C2335) Align the mark on the valve drive with a hole in the outer rim.

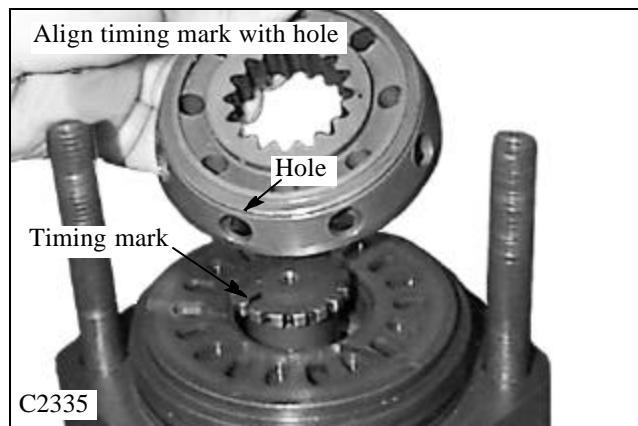

20 Turn the disc valve counter clockwise until the two parts engage. (fig. C2336).

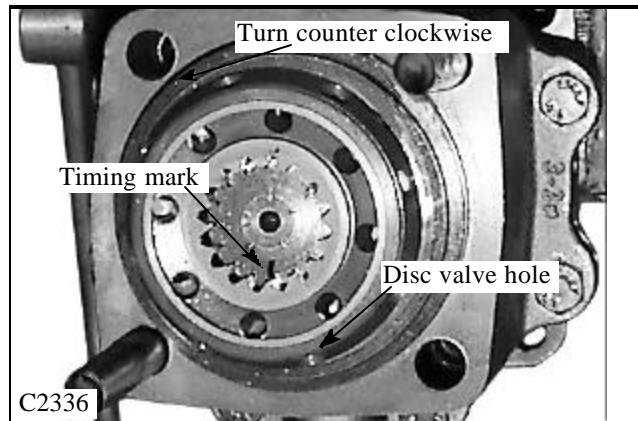

21 Install new seals to the balance plate, install the springs and install the balance plate to valve housing. (fig. C2297). Note the locating pin in the valve housing and the notch in the balance plate.

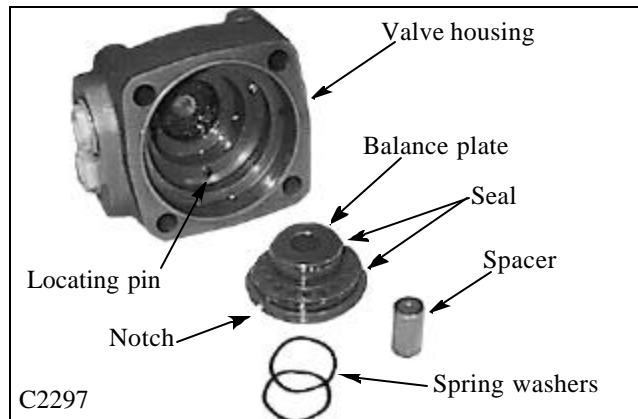

# DRIVE MOTOR 2.12

## Assembly (cont'd)

- 22 Apply petroleum jelly to the spacer. (fig. C2337)  
Install the spacer to the valve housing. (fig. C2338)

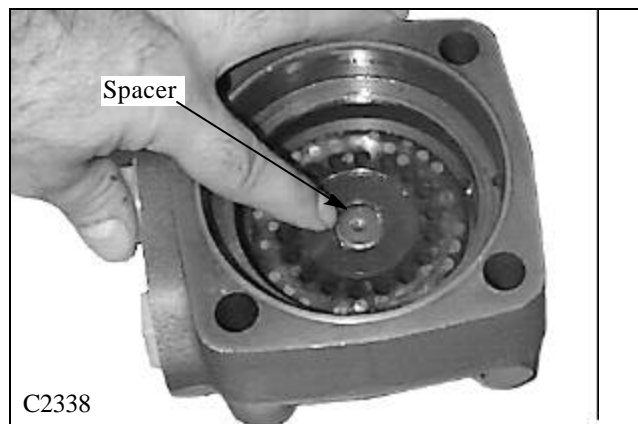
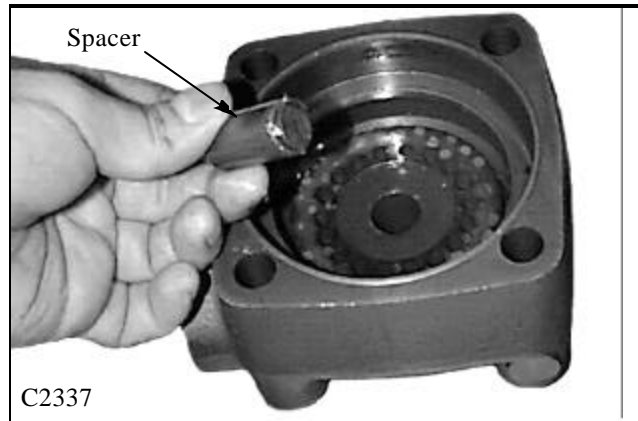

- 23 Install the valve housing to the drive motor. (fig. C2339).

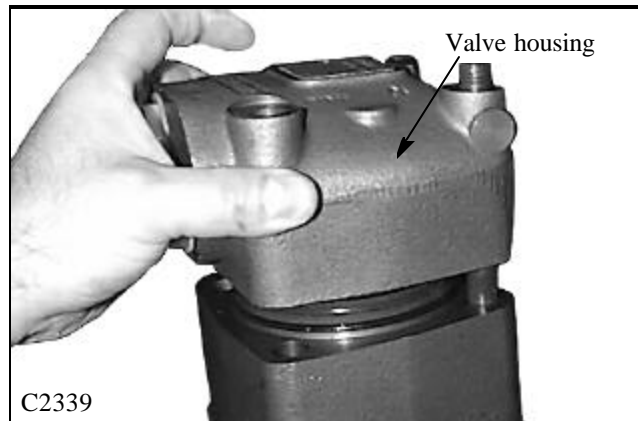

- 24 Install the shuttle valve piston. (fig. C2294).

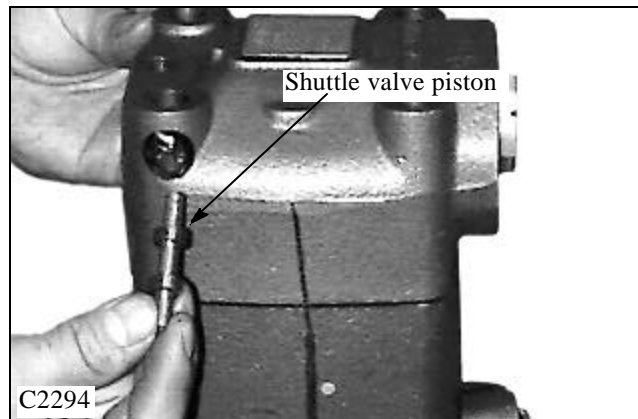

2



## DRIVE MOTOR 2.12

### Assembly (cont'd)

25 Install the shuttle valve springs to either side of the piston. (fig. C2293).

2

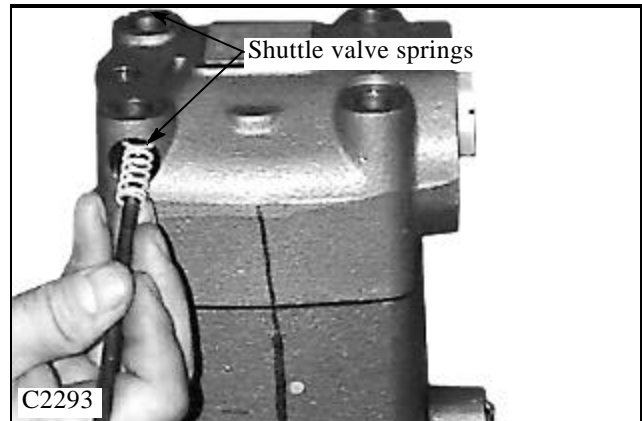

26 Install the shuttle valve plugs. (fig. C2292) Be sure to use new seals when assembling the motor.

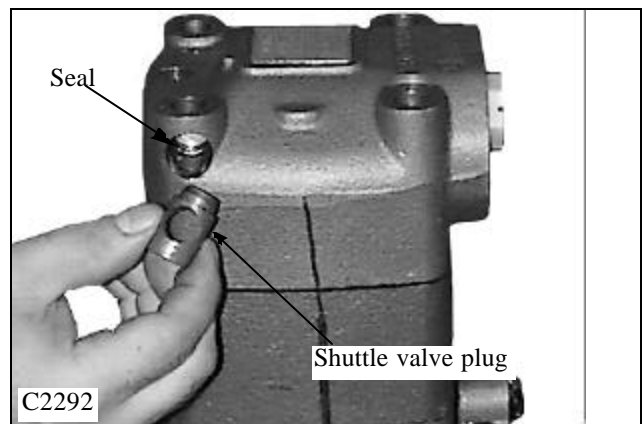

27 Install the bolts to the drive motor and torque in a crisscross pattern to 135 ft lbs. (183 Nm).( fig. C2290).

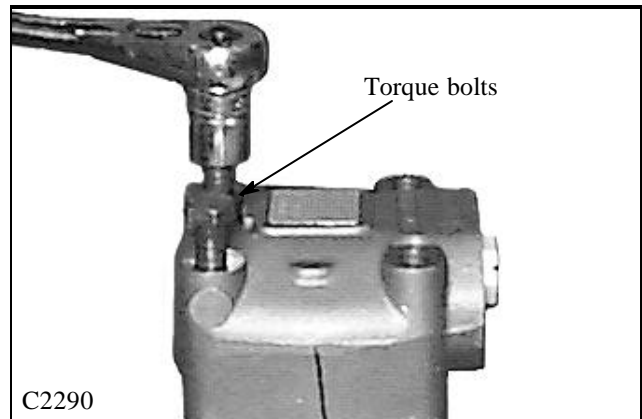

28 Install the restrictor and replace the plug. (fig. C2289).

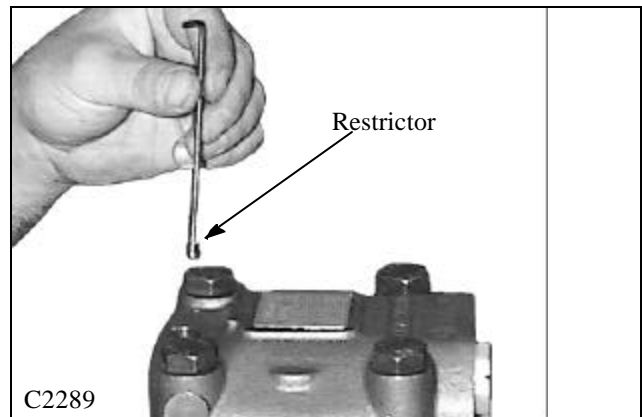

# TORQUE CHART 2.13

**NOTE: all torque specifications are in ft lbs. (Multiply by 1.36 = Nm)**

## Hydraulic Fittings

HOSE SIZE	37° JIC FITTINGS	HOSE SIZE	ORB FITTINGS
1/4	9 to 10	1/4	14 to 16
5/16	15 to 16	5/16	18 to 20
3/8	20 to 22	3/8	24 to 26
1/2	30 to 33	1/2	50 to 60
5/8	40 to 44	5/8	72 to 80
3/4	70 to 77	3/4	125 to 135
7/8	82 to 90	7/8	160 to 180
1	55 to 60	1	200 to 220
1 1/4	120 to 132	1 1/4	210 to 280
1 1/2	131 to 144	1 1/2	270 to 360
2	300 to 330		

**The following torque specifications are for steel ORB fittings into aluminum.**

HOSE SIZE	ORB FITTINGS	HOSE SIZE	ORB FITTINGS
1/4	5 to 7	3/4	40 to 45
5/16	8 to 10	7/8	50 to 55
3/8	10 to 12	1	90 to 99
1/2	21 to 24	1 1/4	80to 90
5/8	27 to 30		

## Tandem Pump

Description	Qty.	Specification
Front Support	1	50 (+/- 2)
Rear Mounting	2	60 (+/- 2)
Trunion Seal Carrier	4	20 (+/- 2)
Trunion Seal Cover	4	20 (+/- 2)
Relief Valve	4	40 (+/- 10)
Charge Relief Cap	1	40 ~ 100
Tandem Section	4	40 (+/- 5)
Gear Pump	2	25 (+/- 2)

## Torque Motor

Description	Qty.	Specification
Valve Housing	4	130
Bearing Housing	8	46.5
Front Cover	8	10.7
Bearing Nut	1	45
Mounting	4	80



# SECTION 3 FINAL DRIVE

Specifications & Maintenance	3.1
Chart .....	pg. 3-2
Lubrication	3.2
Checking the Oil .....	pg. 3-3
Adding Oil .....	pg. 3-3
Changing the Oil .....	pg. 3-3
Drive Chain	3.3
Checking .....	pg. 3-4
Adjusting .....	pg. 3-5
Removal .....	pg. 3-6
Installation .....	pg. 3-7
Chain Tightener	3.4
Removal .....	pg. 3-8
Inspection .....	pg. 3-8
Installation .....	pg. 3-9
Drive Motor Sprocket	3.5
Replacement .....	pg. 3-10
Axle Assembly	3.6
Removal .....	pg. 3-12
Inspection .....	pg. 3-13
Installation .....	pg. 3-14
Stud Replacement .....	pg. 3-17
Trouble Shooting	3.7
Chart .....	pg. 3-18



# SPECIFICATIONS & MAINTENANCE 3.1

## Specifications

Chain Size ..... ANSI 100  
 Approved Chain Manufacturer ..... Tsubaki  
 Lubricating Oil ..... 10W30 API Classification SE/CD  
 Oil Capacity (each)..... 7 Liters. (1.9 gal)  
 Torque Specifications:  
 Chain Tightener Clamp Nuts ..... 150 lbs / ft (203 nm)  
 Motor Sprocket Bolt..... 25 lbs /ft (34 nm)  
 Wheel Nuts ..... 100 - 110 lbs /ft (135 - 149 nm)  
 Tire Pressure ..... 50 psi (345 Kpa)



<b>Maintenance</b>	<b>Initial Check (hrs)</b>	<b>Check Every (hrs)</b>
Tire Pressure.....	8.....	8
Wheel Nut Torque.....	8.....	8
Lubrication Oil.....	50.....	150 (*)
Chain Tension.....	50.....	150
Motor Mounting Nuts .....	50.....	150
Axle Bearing Pre-load.....	50.....	150

(\*) Change every 1000 hours.

# LUBRICATION 3.2

## Checking The Oil Level

The loader has 2 independent final drive housings. When checking the oil level ensure the loader is on a level surface.

- 1 Remove any attachment, raise the boom arms and engage the boom support pins. Shut off the engine.
- 2 Remove the top (upper) check plug located between the 2 tires at the very front of the loader. (fig. C597)  
The oil level should be at the top of the check hole with a little to trickle out.



**Never work under a raised boom arm without the boom supports engaged and the engine shut off.**

## Adding Oil

Oil should be added with the loader on a level surface.

- 1 Remove any attachment, raise the boom arms and engage the boom support pins. Shut off the engine.
- 2 Remove the small inspection cover located to the rear of the steering lever. (fig. C2024)
- 3 Remove the oil level check plug as outlined above. (fig. C597)
- 4 Remove the vented filler plug. (fig. C2038)
- 5 Add 10W30 API classification SE/CD oil until it begins to flow out the upper check hole. Total final drive housing capacity per side is 7 liters (1.9 gal).
- 6 Replace all plugs.



**Check the final drives closely for damaged seals or other leaks if the oil level is excessively low.**

## Changing The Oil

Ensure the loader is on a level surface before changing the oil.

- 1 Remove any attachment, raise the boom arms and engage the boom support pins. Shut off the engine.
- 2 Slide a drain pan under one of the lower drain plugs located at the front of the loader, between the 2 front wheels. (fig. C597) Be prepared to contain 7 liters (1.9 gal) of oil.
- 3 Remove the drain plug. Allow the oil to drip completely out of the final drive housing. Replace the drain plug. Dispose of the waste oil in an environmentally friendly manner. If the oil is contaminated, remove the side inspection cover to flush the housing. (fig. C2073)
- 4 Replenish the oil as outlined above in Adding Oil with 10W30 API classification SE/CD oil.

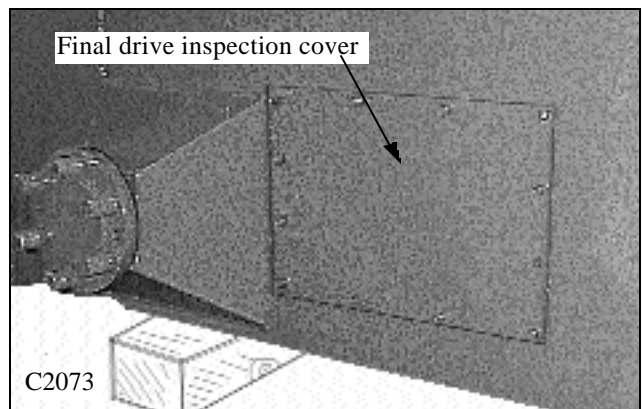
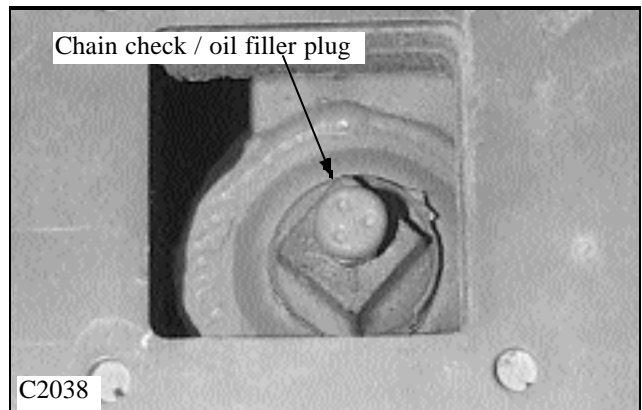
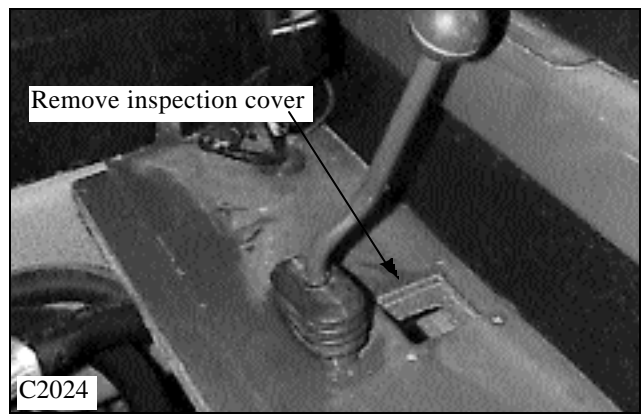
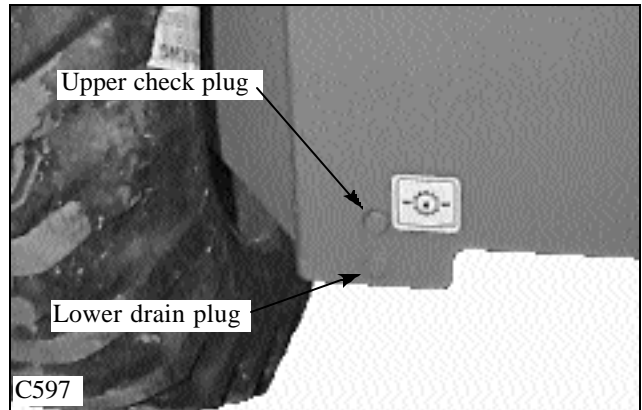

# DRIVE CHAIN 3.3

## Checking The Drive Chain

The drive chain must be checked for adjustment after the first 50 hours of service and every 150 hours thereafter. Correct chain tension must be set to 1/4 to 3/8 inches (6 to 9mm) free play.

- 1 Remove any attachment, raise the boom arms and engage the boom support pins. Shut off the engine.
- 2 Remove the small inspection cover located to the rear of the steering lever. (fig. C2024)



3

- 3 Remove the vented filler / check plug. (fig. C2038)

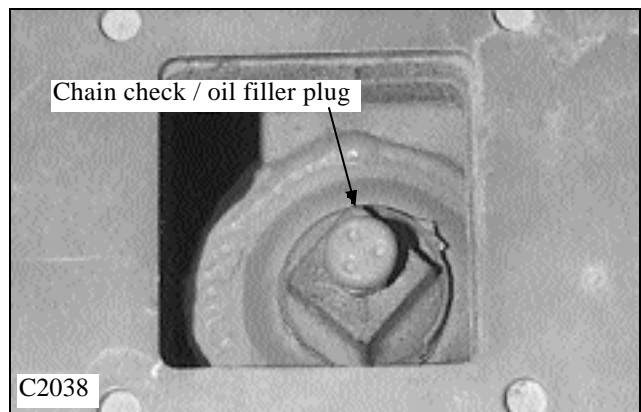

- 4 Check the chain tension using the special tension tool P/ N 960997. Slide the special tool into the filler hole and use the hooked end to grab under the chain. (fig. C372) Pull upward on the tool using a force equal to approximately 30 lbs (13.6 kg) pull. The special tool is calibrated in 1/4 inch increments. (6mm) Correct adjustment is calculated by the number of marks the special tool moves. The special tool should only move 1/4 to 3/8 inches (6 to 9mm) at a 30 lbs (13.6kg) pull. Replace the plug if no further adjustment is required.

- 5 Apply a thread sealant to the inspection / fill plug before replacing. (fig. C2279)

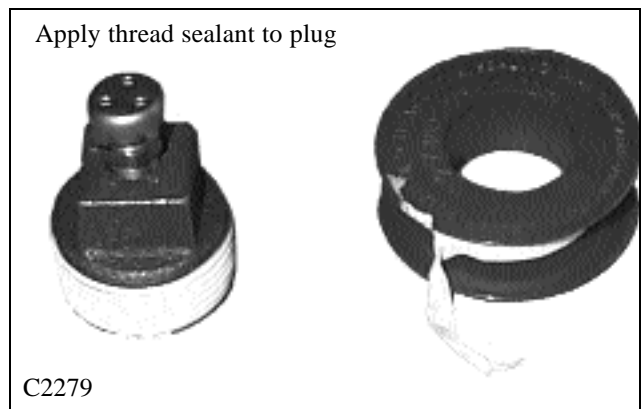

# DRIVE CHAIN 3.3

## Adjusting The Drive Chain

After checking the chain for proper free play, you may need to make an adjustment.

1 Access the chain tightener located at the front of the operators compartment, just above the foot rests, by removing the cover shield. (fig. C2008)

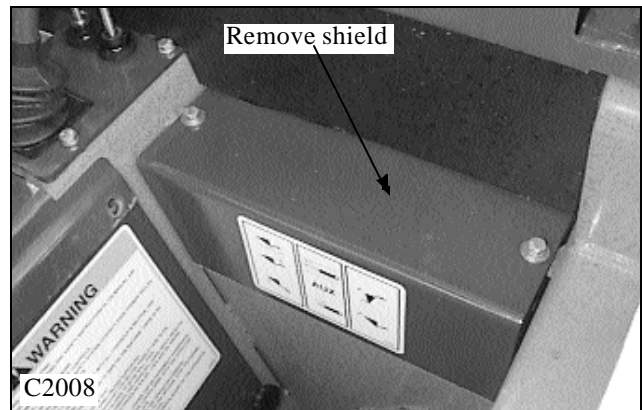

2 Loosen the 3 tightener nuts approximately 1/4 turn. (fig. C2009) Do not loosen too much. This would allow the chain tightener to drop too low and give a false reading when the chain is checked for tension.

3 Loosen the rear adjuster nut. (fig. C2009) Turn the forward nut in to tighten, or out to loosen, the chain.

4 Inspect the chain adjustment again. It must be 1/4 to 3/8 inches (6 to 9mm) at 30 lbs pull (13.6kg).

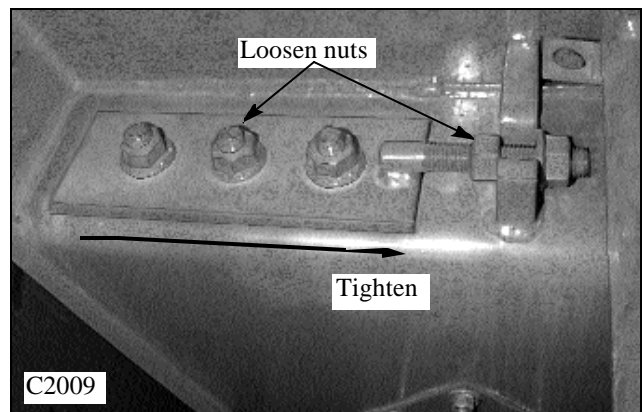

5 Torque the 3 chain tightener nuts to 150 lbs/ft (203nm) And recheck the chain tension. (fig. C2270)

6 Tighten the adjuster nut against the plate. Re-seal the plugs and replace the inspection covers.

If proper chain tension adjustment can not be reached using the adjuster plate the chain will need to be replaced. Do not remove extra links from the chain. It has reached it's normal service life and must be replaced.

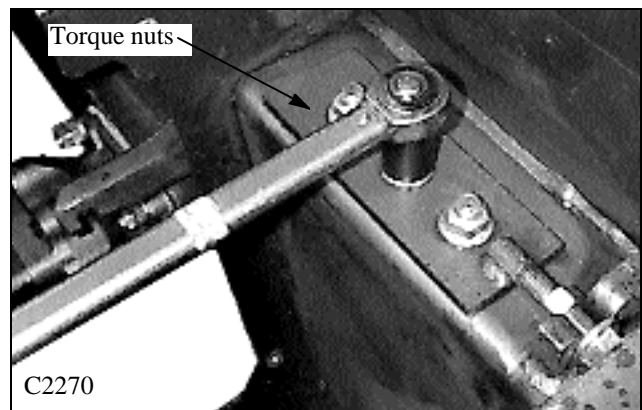

### IMPORTANT

**Adjusting the chain tension too loose will allow the chain to "WHIP" and possibly cause part failure.**

7 Replenish the final drive housing with 7 liters 1.9 gal) of API classification SE / CD oil.

8 Install the wheels and torque the wheel nuts to specs on page 3-2. (fig. C1658)



# DRIVE CHAIN 3.3

## Chain Removal

- 1 Remove any attachment, raise the boom arms and engage the boom support pins. Shut off the engine.
- 2 Block the loader securely with all 4 wheels clear of the ground.
- 3 Remove the wheels from the side of the loader the chain is to be removed.
- 4 Clean the excess dirt from the final drive housing drain plug area and the inspection cover area located between the 2 axle towers. (fig. C168)
- 5 Remove the lower drain plug and drain the oil. Refer to Section 3.2 page 3-3.
- 6 Remove the final drive inspection cover. (fig. C168)
- 7 Rotate the chain, if necessary, to locate the master connecting link by starting the engine and engaging the steering control. Be sure the loader is securely raised clear of the ground.
- 7 Loosen the 3 chain tightener nuts. Refer to Adjusting the drive Chain page 3-5.
- 8 Loosen the adjuster nuts and allow the tightener to fully release the tension on the chain. (All the way back in the adjustment slots).

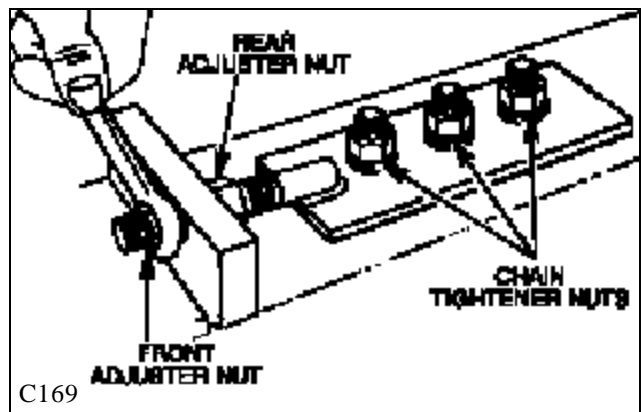
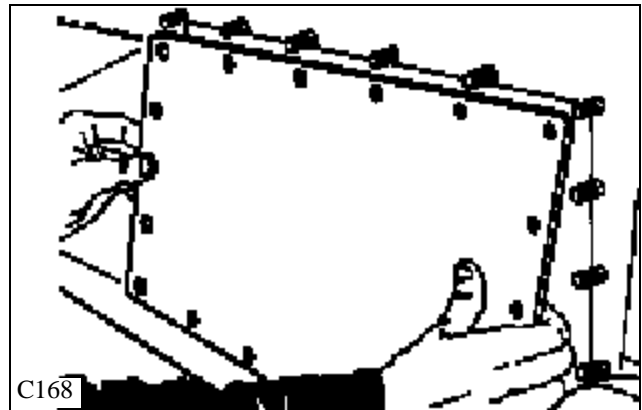

- 9 Remove the cotter pins from the master connecting link and remove the connecting link. (fig. C2271) The connecting link is a press fit type and will need to be supported as you drive the link pins through the link plate.

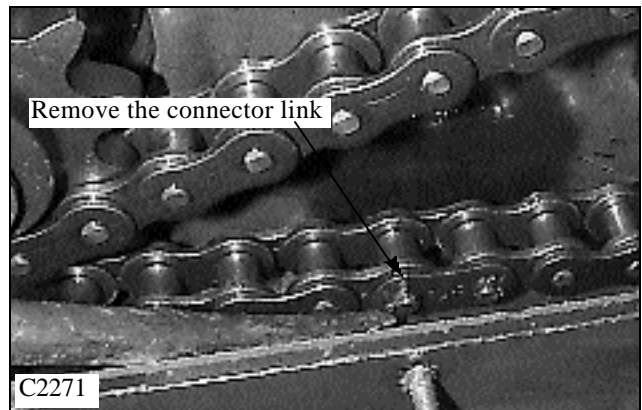

- 10 Remove the chain from the housing by turning the axles by hand and pulling the slack chain out the inspection cover area. (fig. C2273) Hold the chain up off the drive sprocket to allow the chain to rotate freely.

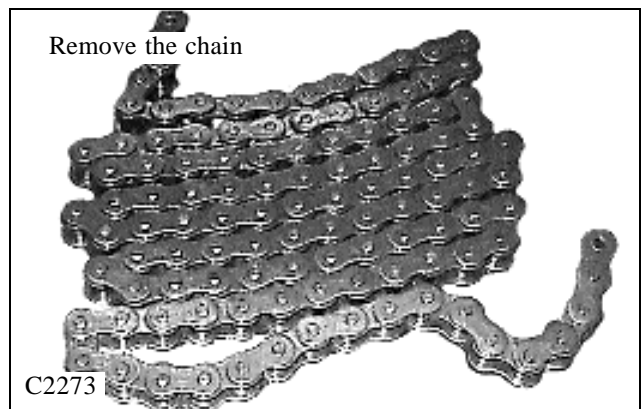



# DRIVE CHAIN 3.3

## Chain Installation

- 1 Make sure the chain tightener and adjuster are clear rearward in the adjustment slots.
- 2 Wrap the chain in a “Z” pattern as shown in fig. C2273.
- 3 Install the wrapped chain into the final drive housing.

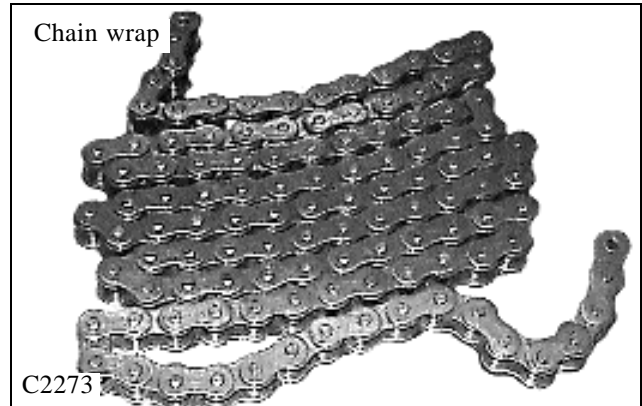

- 4 Place one end of the chain over the top of the rear axle sprocket. Rotate the axle and bring the chain along the bottom of the final drive housing to approximately the center. (fig. C243)

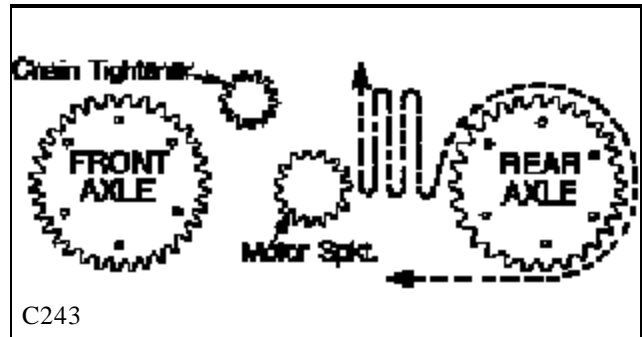

- 5 Place the other end of the chain over the top of the chain tightener sprocket and bring it back around the drive motor sprocket. (fig. C239)
- 6 Wrap the chain over the front axle sprocket. Rotate the axle and chain around the bottom of the final drive housing until the ends of the chain meet together.

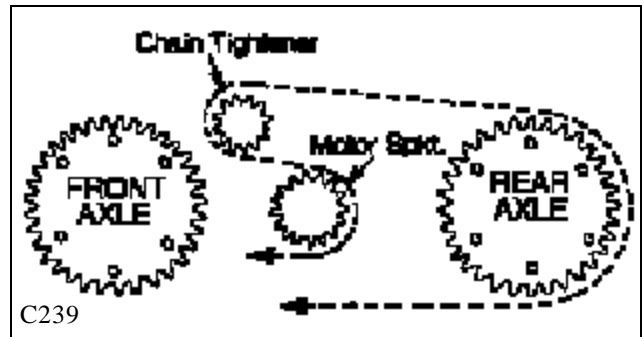

- 7 Install a new connecting link. (fig. C2271) Place the connecting link into the chain so the cotter pins face the inspection cover hole. Bend the ends of the cotter pins at least 90 ° apart.
- 8 Adjust the chain tension as outlined on page 3-5.
- 9 Replace the inspection cover using silicone. Do not over tighten the inspection cover nuts. 18 lbs / ft maximum. (24.5 nm)
- 10 Replace the wheels and torque the wheel nuts to 100 to 110 lbs/ft. (136 to 149 nm).

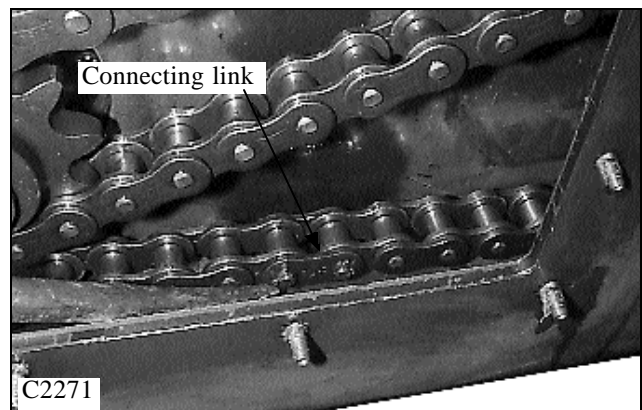

3

# CHAIN TIGHTENER 3.4

## Chain Tightener Removal

- 1 Remove any attachment, raise the boom arms and engage the boom support pins. Shut off the engine.
- 2 Block the loader securely with all four wheels clear of the ground.
- 3 Remove the wheels from the side of the loader to be repaired.
- 4 Drain the lubricating oil from the final drive housing. Refer to Section 3.2 page 3-3.
- 5 Remove the final drive inspection cover located between the 2 axles.
- 6 Loosen the chain tightener and adjuster and disconnect the chain. Refer to Section 3.3 page 3-5.
- 7 Rotate the front axle and pull the excess chain rearward through the chain tightener sprocket. Leave the chain in the housing.
- 8 Remove the 3 chain tightener nuts. You may require some help to hold the tightener assembly as you release the nuts. The tightener is now free to be removed.

3

## Inspection

Follow fig. C1173 to disassemble the chain tightener assembly. Note the finely machined thrust washers used on either side of the sprocket. The 2 spacer washers are used to align the sprocket with the axle sprocket and chain. The spacer washers are always used next to the head of the bolt, away from the threaded side of the tightener bracket.

Inspect the thrust washers, sprocket, sprocket bearing surface, bearing and idler shaft for scaring or excessive wear. Replace worn parts as required.

When assembling the new components, use Loctite type 609 (red) to the threaded area of the tightener bracket assembly. Torque the bolt to 180 lbs/ft (245 nm).

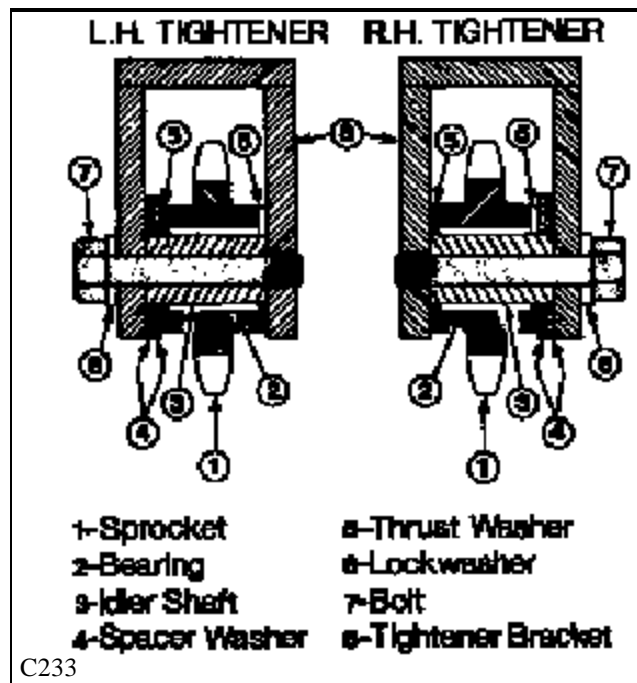
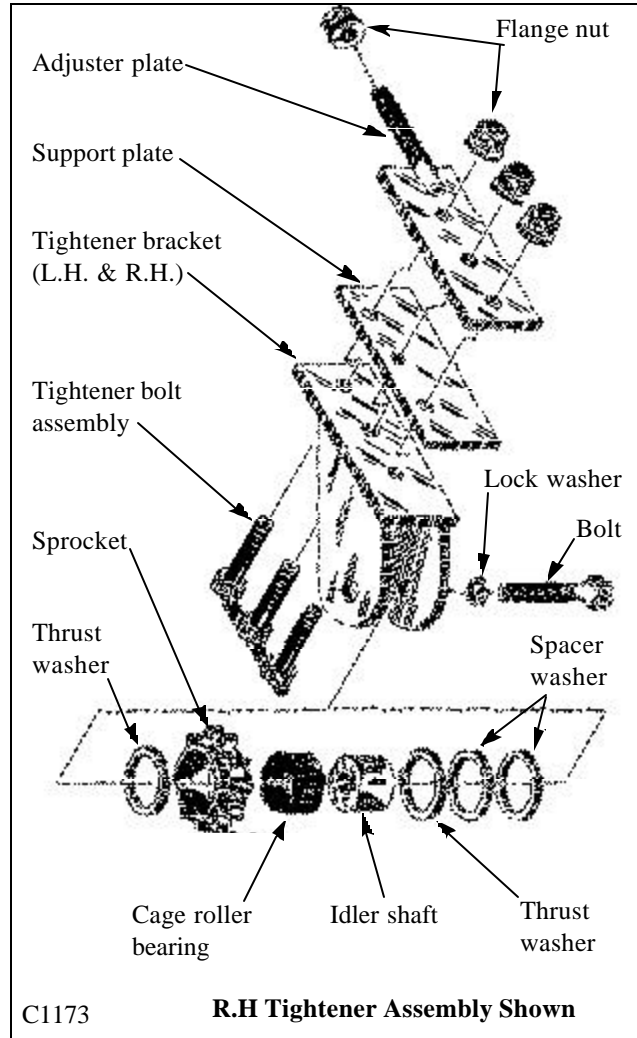

# CHAIN TIGHTENER 3.4

## Chain Tightener Installation

1 Assemble the left and right chain tightener assemblies as shown in fig. C233 on the previous page. Make sure to place both spacer washers next to the side of the tightener where the bolt screws in. (Always toward the outside of the loader). Use Loctite type 609 (red) on the threaded area of the tightener bracket to help secure the bolt. Torque the bolt to 180 lbs/ft. (245 nm) The chain tighteners are offset differently for the left and right hand side. Be sure to place the tightener assemblies into the correct housing. The head of the bolt always faces toward the outside of the loader. (Toward you as you install into the loader).

2 Install the bolt assembly into the tightener bracket. (fig. C234)

3 Install the support plate onto the chain tightener. The support plate holes are drilled off center. Install the support plate so that it extends beyond the chain tightener bracket on the bolt head side. (fig. C235)

4 Apply elastomer sealant around the bolt threads and support plate. (fig. C2267)

5 Apply elastomer sealant to the adjustment slots located on the loader housing. (fig. C2268)

6 Install the adjuster plate to the frame and apply elastomer sealant around each bolt assembly hole.

7 Install the tightener assembly to the frame. You may need an extra pair of hands to hold the tightener in place, while someone installs the 3 flanged locking nuts. Only hand tighten the nuts.

8 Place the drive chain around the chain tightener idler sprocket. Loop it around the drive motor sprocket, and then install the connecting link to the chain.

9 Tighten the 3 chain tightener bolts and loosen 1/4 turn. Adjust the drive chain tension as outlined on page 1-5.

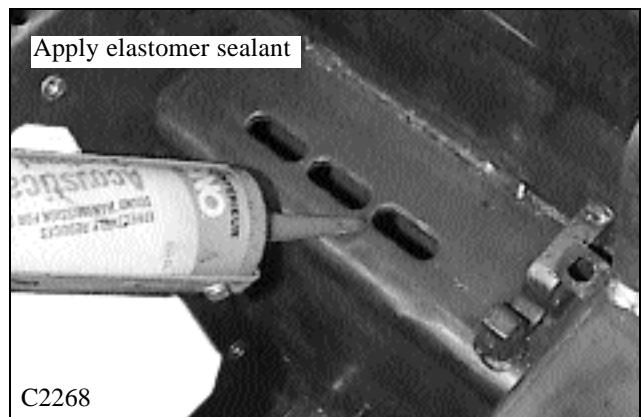
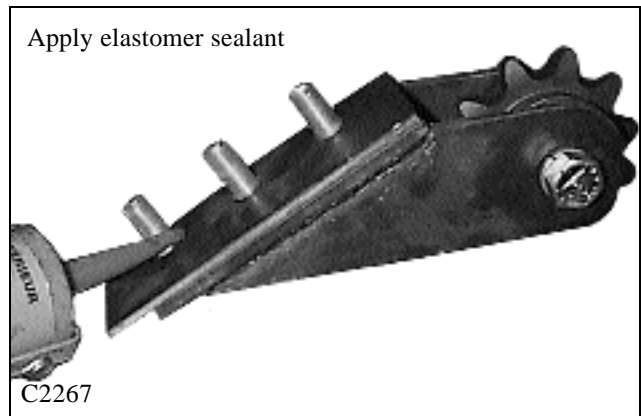
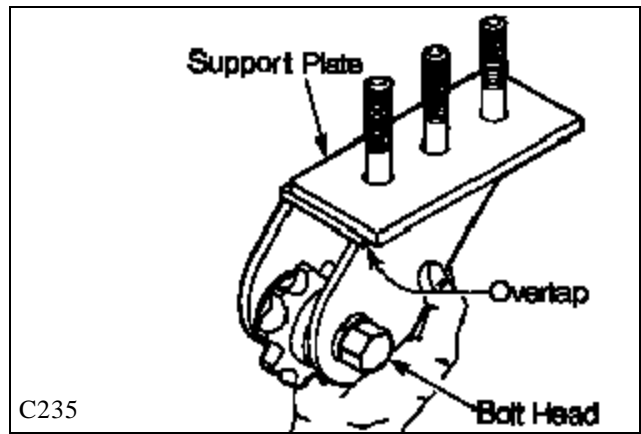
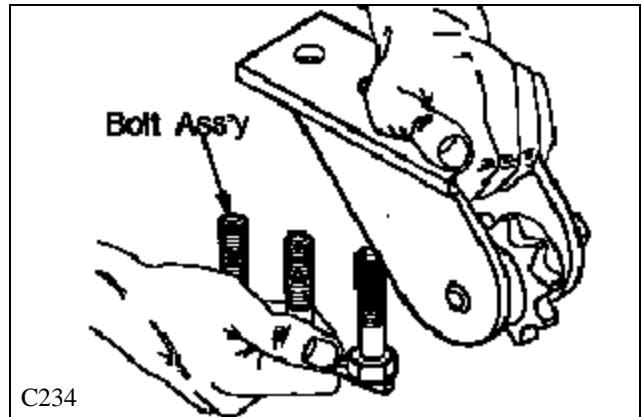

# DRIVE MOTOR SPROCKET 3.5

## Replacement

The torque motor drive sprocket can be removed from the loader without removing the drive motor from the final drive housing.

- 1 Place the loader on a level surface, engage the parking brake and shut off the engine.
- 2 Raise the loader securely from the ground and remove the wheels on the side to be worked on.
- 3 Remove the inspection cover located between the axle assemblies. (fig. C2073)

3

- 4 Loosen the drive chain to its' slackest position. (fig. C2009) See page 1-6 for assistance.

- 5 Remove the bolt retaining the drive sprocket to the drive motor. (fig. C2272)
- 6 Pull the chain away from the sprocket and slide the sprocket off the drive motor shaft. (fig. C2232)
- 7 Replace the drive sprocket in the reverse order above. Apply Loctite 242 (blue) to the drive sprocket bolt and torque the bolt to 28 lbs / ft (38 Nm)

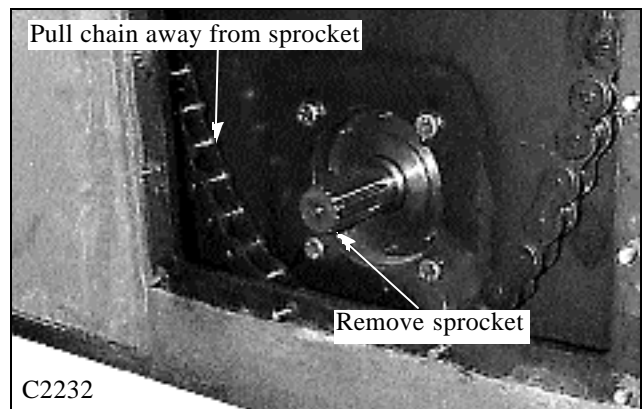
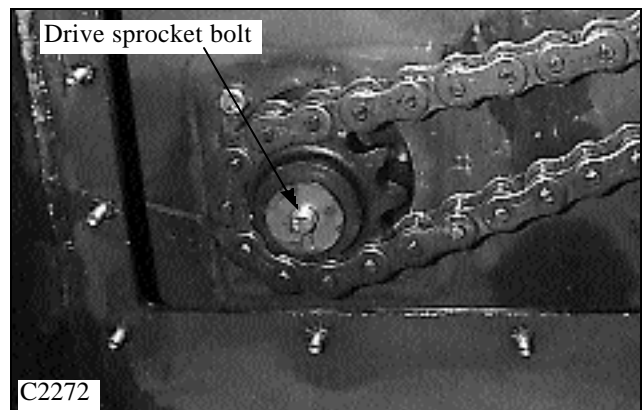
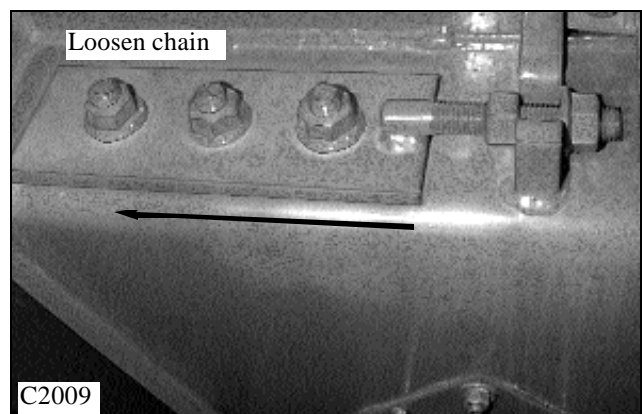
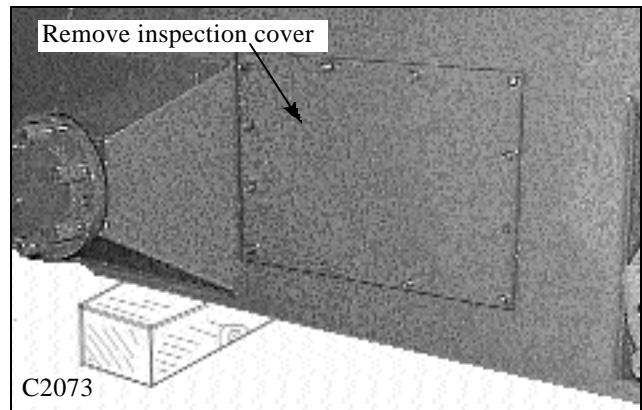

# AXLE ASSEMBLY 3.6

Axle Assembly T - 135 S

C1172

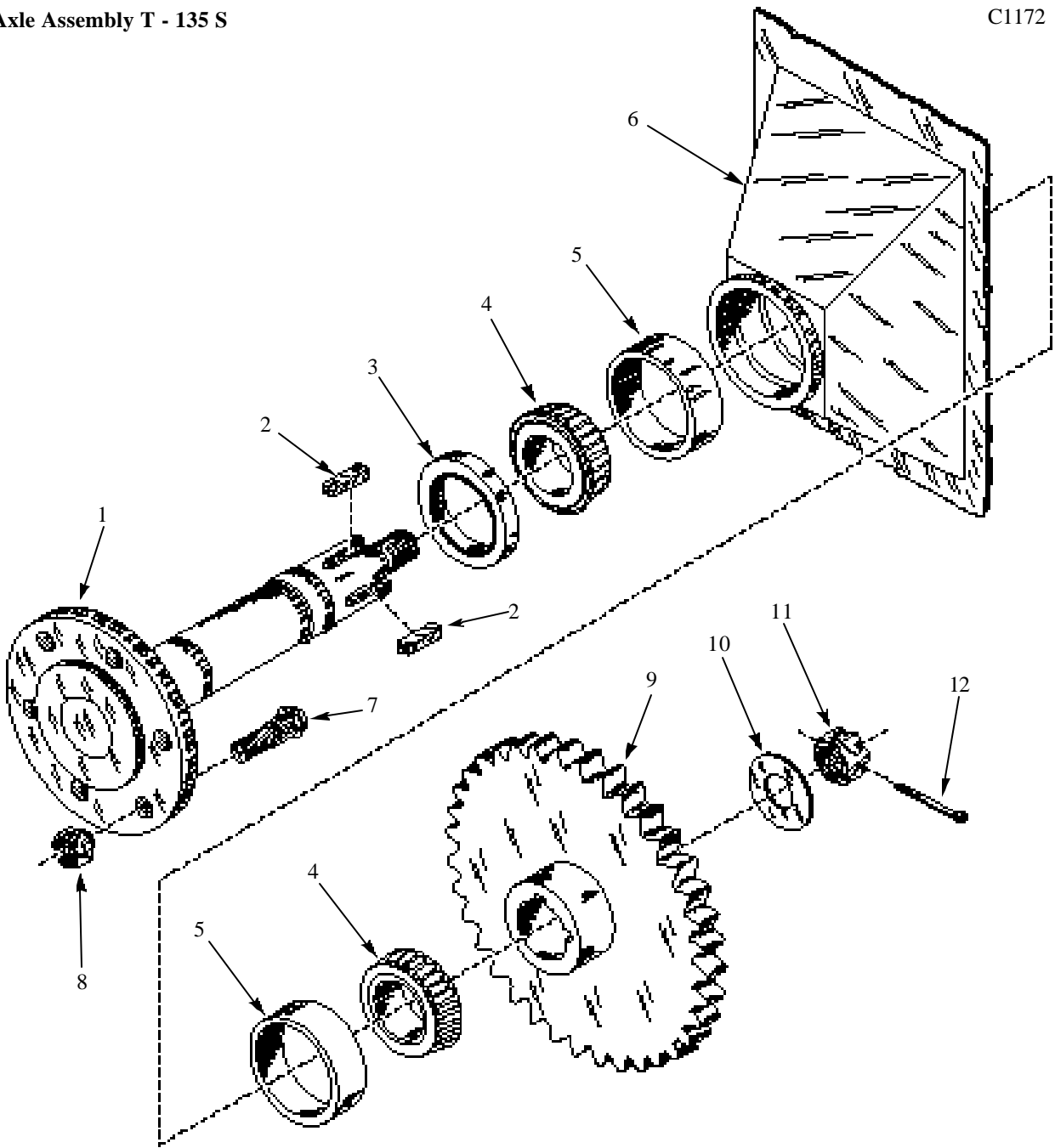

- |   |              |    |               |
|---|--------------|----|---------------|
| 1 | Axle         | 7  | Wheel Stud    |
| 2 | Key          | 8  | Wheel Nut     |
| 3 | Seal         | 9  | Axle Sprocket |
| 4 | Bearing      | 10 | Washer        |
| 5 | Race         | 11 | Castle Nut    |
| 6 | Axle "Tower" | 12 | Cotter Pin    |



# AXLE ASSEMBLY 3.6

## Axle Removal

- 1 Remove any attachment, raise the boom arms and engage the boom support pins. Shut off the engine.
- 2 Block the loader securely with all 4 wheels clear of the ground.
- 3 Remove the wheels from the side of the loader the chain is to be removed.
- 4 Clean the excess dirt from the final drive housing drain plug area and the inspection cover area located between the 2 axle towers. (fig. C)
- 5 Drain the lubricating oil from the final drive housing. Refer to Section 3.2 page 3-3.
- 6 Remove the final drive inspection cover located between the 2 axles.
- 7 Remove the drive chain from the final drive housing. Refer to Section 3.3 page 3-6.
- 8 **FRONT AXLE:** Remove the foot pedal assembly if so equipped. Refer to Section 4.
- 9 Remove the inner axle cover plate from the final drive housing. (fig. C219)
- 10 **REAR AXLE:** Remove the inner axle cover plate from the final drive housing.
- 11 Remove the split pin from the castle nut on the end of the axle. (fig. C227)

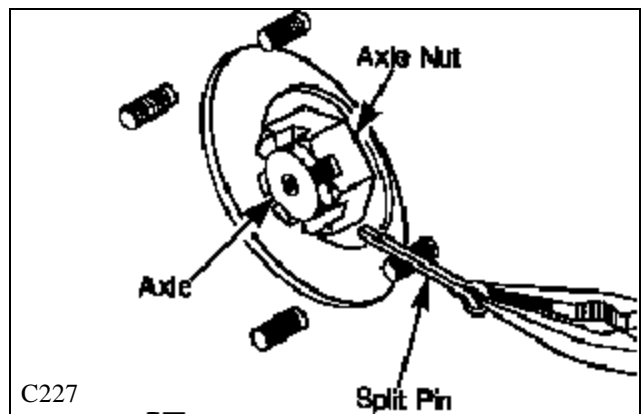
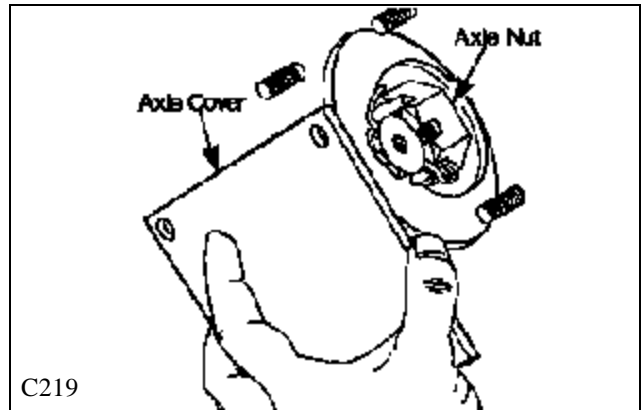

- 12 Install a bolt, 1/2 UNC approximately 3'' long, through the axle flange and into the final drive housing to prevent the axle from turning as the castle nut is removed. (fig. C206)

**Note:** Later model machines may not be equipped with the nut welded to the axle tower. The axle may be held stationary by inserting a bar between the wheel studs.

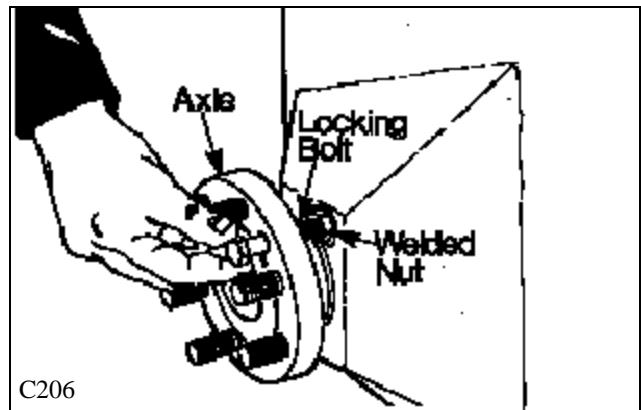

- 13 Remove the rear castle nut and axle washer. (fig. C217)
- 14 Remove the bolt from the axle flange that was installed to keep the axle from turning.

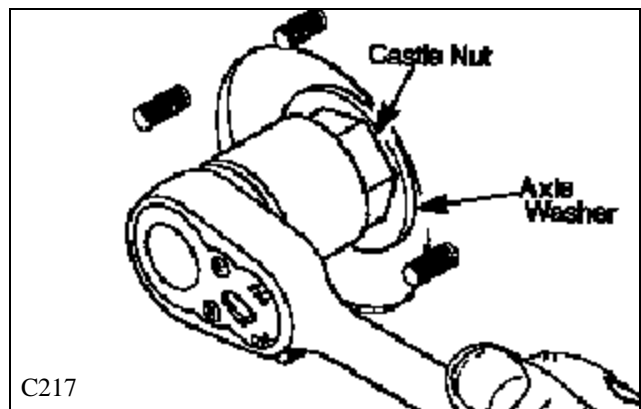

3

# AXLE ASSEMBLY 3.6

- 15 Attach a special axle puller tool, Thomas P/N 955283, to the axle flange wheel studs using the wheel nuts that are on the loader. (fig. C228)
- 16 Using the slide hammer action of the special puller, remove the axle. The rear bearing and axle sprocket will remain in the final drive housing.
- 17 Remove the axle sprocket and bearing from the final drive housing through the inspection cover area.

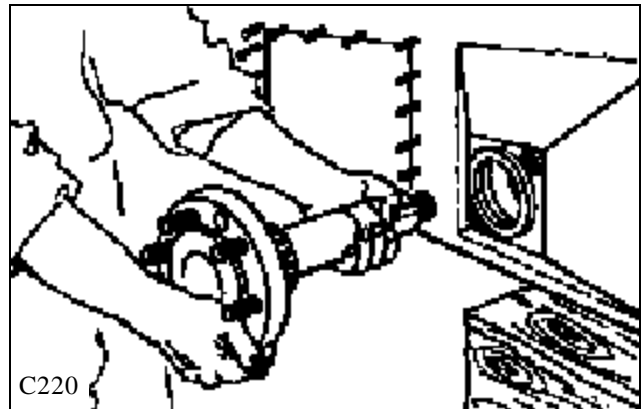
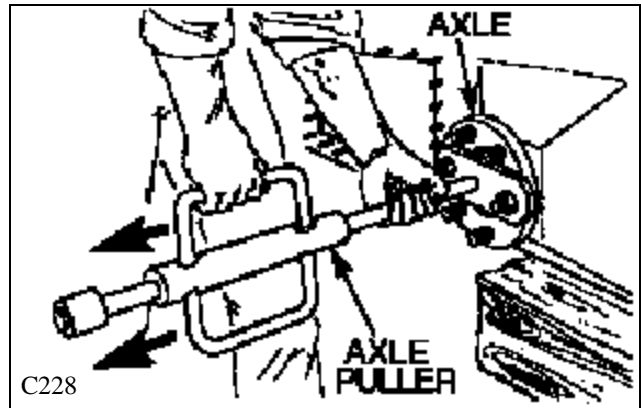

- 18 Using a bearing puller, remove the bearing still pressed in place on the axle. (fig. C221)
- 19 Remove and discard the axle oil seal.

## Inspection

- 1 Inspect the seal surface area for scaring, pitting or nicks. Minor scratches may be removed using fine emery cloth. Replace the axle if worn excessively.
- 2 Inspect the axle threads for damage. Replace axle if the threads are non serviceable.
- 3 Inspect the axle keys for wear. Replace as required.
- 4 Inspect the key way slots for wear. Replace the axle and keys if the keys do not fit tightly into the key ways.
- 5 Replace any axle studs as required.
- 6 Inspect the axle sprocket for abnormal tooth wear and the fit of the axle key in the sprocket key ways. Replace the sprocket if necessary.
- 7 Inspect the bearing races in the final drive housing. Replace them if necessary using a brass drift punch and hammer. Cooling the races in a freezer will aid in easing this procedure.
- 8 Replace the bearings if new races are installed or if they are pitted or damaged.

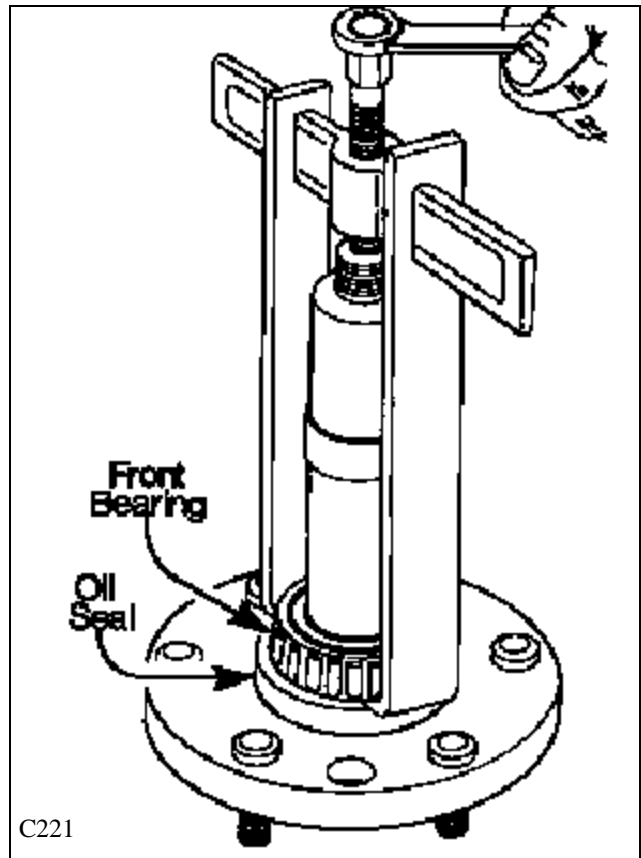

# AXLE ASSEMBLY 3.6

## Axle Installation

- 1 Check the axle seal surface area for damage. Minor scratches may be repaired using fine emery cloth.
- 2 Inspect the axle threads for damage. Replace axle if the threads are non serviceable.
- 3 Inspect the key way slots for wear. Replace the axle and keys if the keys do not fit tightly into the key ways.
- 4 Replace any axle studs as required.
- 5 Lubricate the axle oil seal with light grease.
- 6 Install the seal onto the axle. The seal part number stamping must face the flange side of the axle. (fig. C222)
- 7 Using a press, install the front, or outer, bearing onto the axle. Be sure to support the axle up off the wheel studs to prevent damaging the wheel studs. (fig. C223)

3

- 8 Place 3 seal installation tools, Thomas P/N 955281, Equally spaced around the axle flange, behind the seal as shown in fig. C224. (approximately 120° increments). These special tools must be used to properly locate the seal into the final drive housing.

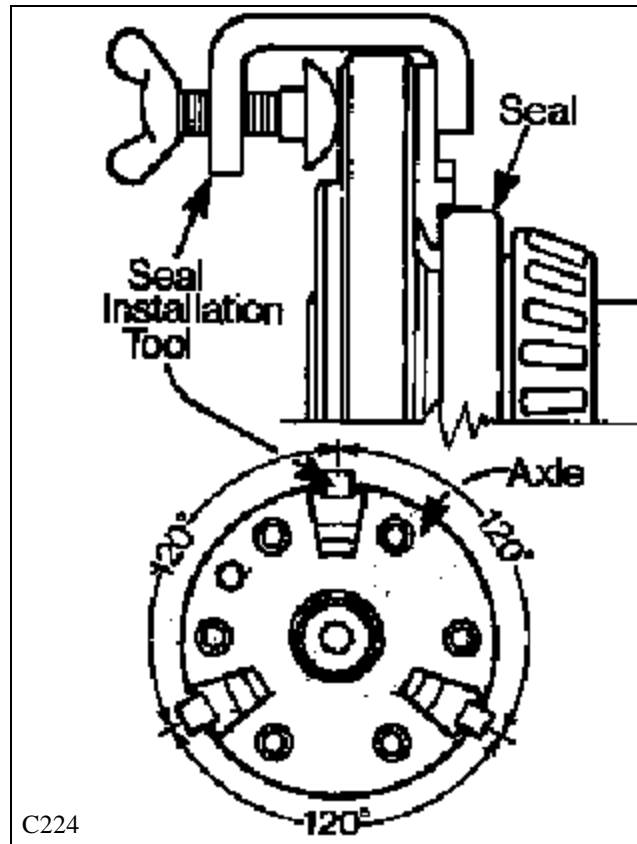
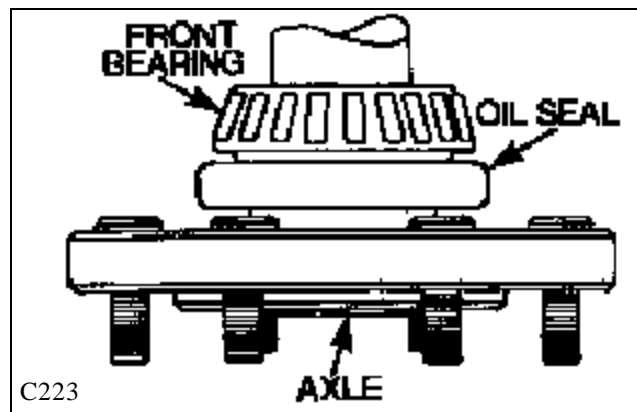
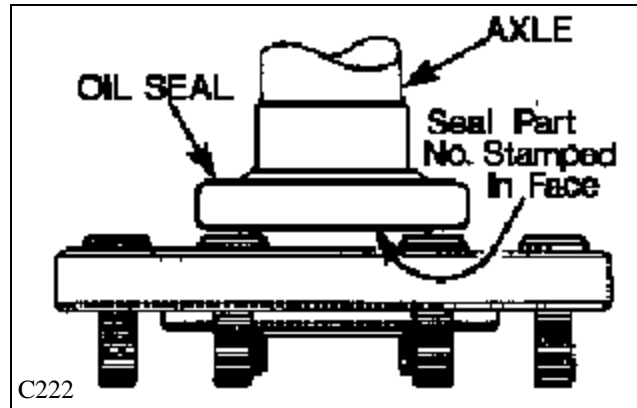



# AXLE ASSEMBLY 3.6

9 Place the axle sprocket into the final drive housing with the hub facing toward the bearing race area. (outside)

10 Apply gasket sealant to the outer edge of the axle oil seal. (fig. C212) Take care, make sure none gets on the bearing surface.

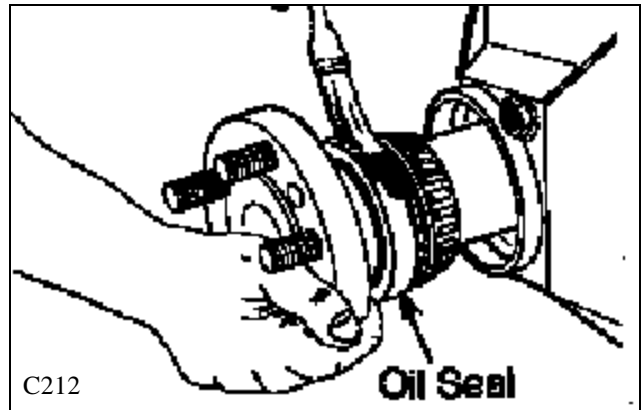

11 Guide the axle into the final drive housing. (fig. C220)

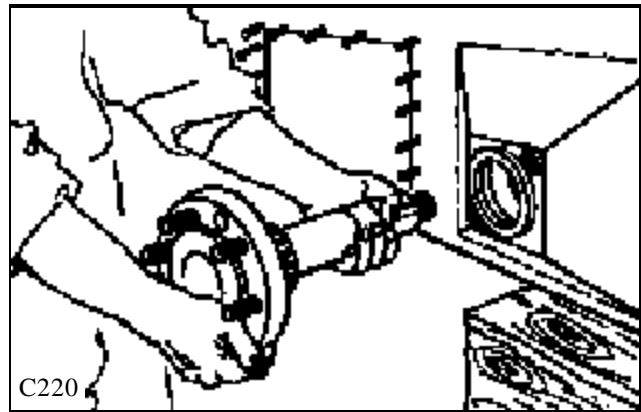

12 Place the rear (inside) axle bearing onto the axle.

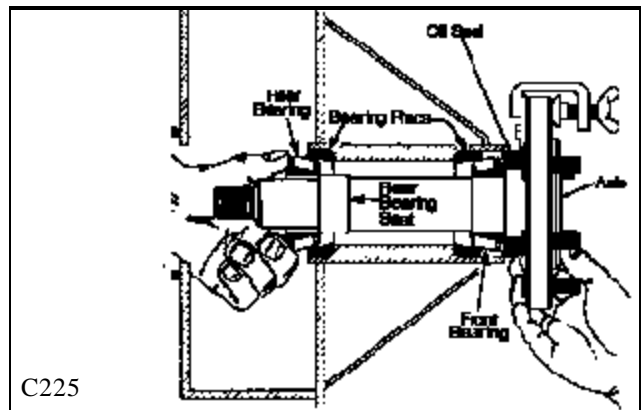

13 Start the axle into the drive sprocket. Place the axle washer and castle nut onto the threaded end of the axle.

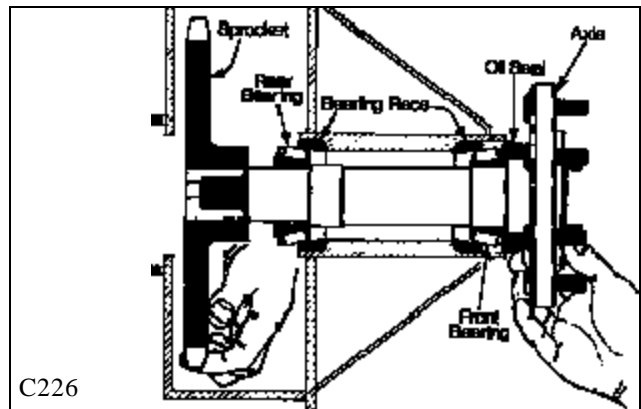

# AXLE ASSEMBLY 3.6

14 Place a bolt (1/2 x 3'') through the axle flange and screw it into the final drive housing to prevent the axle from turning as the castle nut is being tightened. (fig. C206)

**Note:** Later model machines may not be equipped with the nut welded to the axle tower. The axle may be held stationary by inserting a bar between the wheel studs.

15 Tighten the castle nut and guide the axle into the final drive housing as straight as possible to prevent damaging the seal. Tap the axle flange with a hammer if necessary to assist the installation.

As the castle nut is being tightened the rear (inside) bearing is being pressed into place and the axle oil seal is simultaneously pulled into the proper location into the final drive housing.

16 When the castle nut will not turn on any further tap the face of the flange with a hammer to ensure the seal and bearing has seated into place.

17 Remove the castle nut, axle washer and remove the axle oil seal installation tools.

18 Line up the axle and sprocket key ways and install the keys into the key way slots. (fig. C216) Use a brass drift punch and hammer if necessary to install the keys into the key way slots.

19 Install the axle washer and castle nut. Tighten the castle nut to remove all axle bearing end play. (Zero pre-load) Continue tightening until the split pin hole in the axle will align with the castle nut.

20 Install the split pin. Bend the end of the split pin straight back against the axle washer.

21. Install the axle cover using silicone to seal the matting surfaces. Do not over tighten the retaining nuts. 15 lbs/ft maximum. (20 nm)

22 Install the drive chain. Refer to Section 3.3 page 3-7.

23 Fill the final drive housing to the correct level using 10W30 API classification SE/ CD oil. Refer to Section 3.2 page 3-3 for procedure.

24 Install the inspection cover using silicone to seal the matting surfaces. Do not over tighten the retaining nuts. 15 lbs/ft maximum. (20 nm)

25 Install the wheels. Torque the wheel nuts to 100 to 110 lbs/ft. (135 to 149 nm).

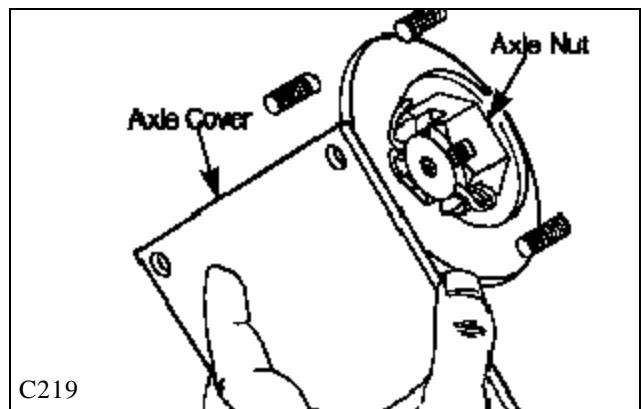
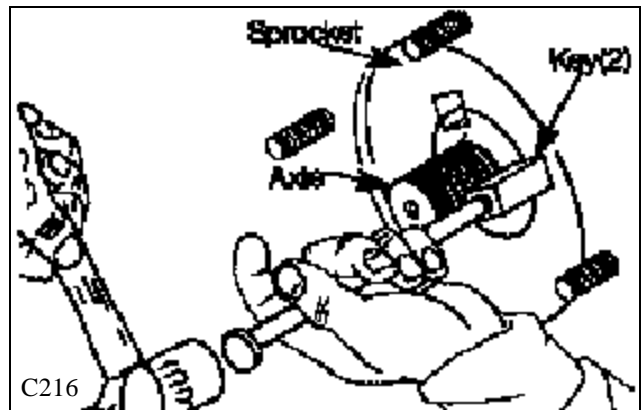
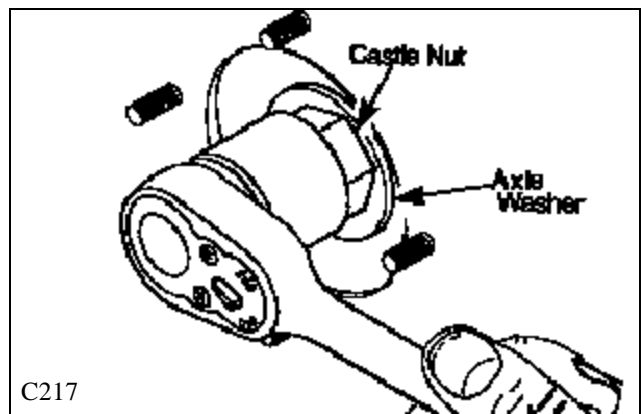
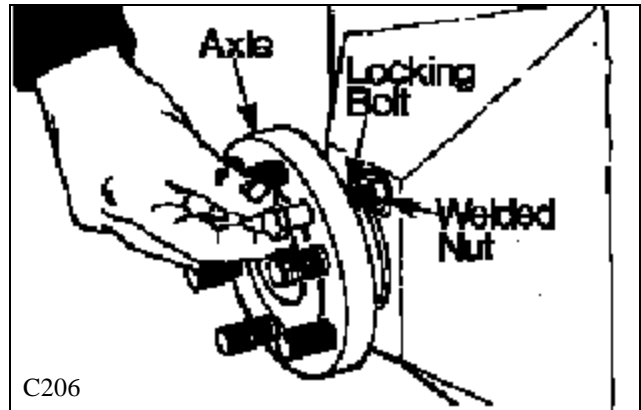

# AXLE ASSEMBLY 3.6

## Axle Stud Replacement

- 1 Lower the boom arms and shut off the engine.
- 2 Raise and block clear of the surface the loader side of the loader the wheel studs are to be changed on.
- 3 Remove the wheel the studs are to be replaced on.
- 4 Remove the damaged or broken stud by rotating the axle so the damaged stud is at the 12:00 o'clock position as shown in fig. C209. The axle "tower" is relieved, or notch, in this location to allow stud removal without removing the axle assembly.
- 2 Strike the stud with a hammer to remove from the axle flange. (fig. C209)

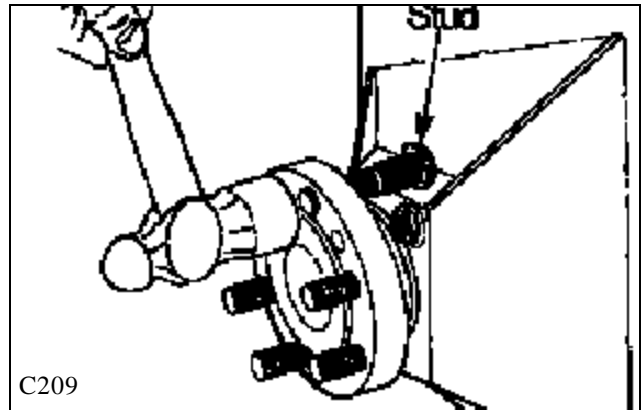

- 3 Place a new stud in position behind the axle flange. Line up the splines on the stud with the splines cut into the axle flange. (fig. C210)

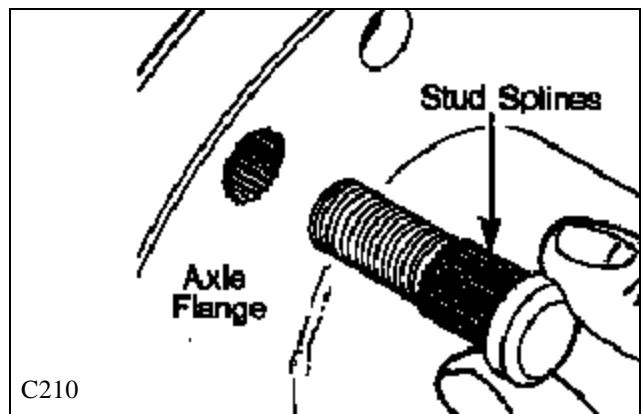

- 4 Place a wheel nut on the stud and use it to draw the stud into place in the axle flange as you tighten it. (fig. C211)
- 5 Replace the wheel and torque the wheel nuts to 100 to 110 lbs/ft. (135 to 149 nm)

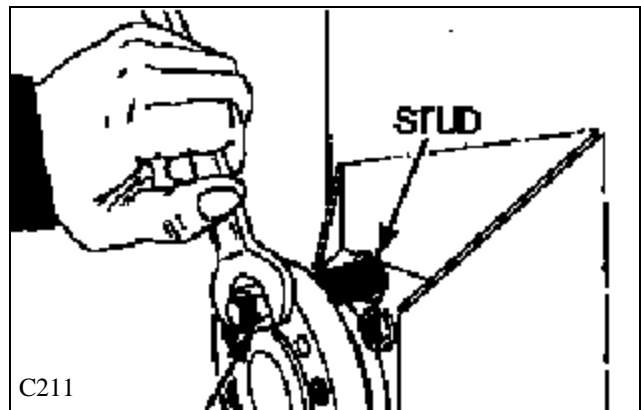

### IMPORTANT

**Torque the wheel nuts daily to prevent stud and/or wheel damage.**



# TROUBLE SHOOTING 3.7

**3**

Problem	Cause	Corrective Action	Section
Final drive noisy.	No lubricating oil.	Check oil level. Add 10W30 SE/CD oil to correct level.	3.2
	Chain is loose.	Adjust the chain tension. Check chain tension every 150 hours.	3.3
	Axle has too much end play. (Bearing pre-load)	Check and adjust the bearing pe-load on the axle bearings	3.6
	Chain tightener damage or failure.	Inspect the chain tightener and repair if necessary.	3.4
No drive on one side.	Drive chain failure.	Inspect the drive chain and connecting link. Replace damaged parts. Check the chain tension every 150 hours.	3.3
	Drive motor sprocket failure	Inspect the drive sprocket and splines. Replace parts as required.	3.5 2
	Drive motor or hydrostatic system failure	Refer to the hydrostatic drive section. Diagnose and make repairs as required.	2
Lubrication oil leaking through the filler / breather cap.	Lubricating oil level too high.	Check the oil level.	3.2
	Drive motor shaft seal leakage.	Inspect and repair damaged parts.	2
Wheel studs shearing off.	Wheel nuts loose.	Replace the wheel studs. Check wheel nut torque daily. Torque wheel nuts at 100 to 110 lbs/ft. (135 to 149 nm)	3.6
Wheel stud threads stripped.	Wheel nuts over tightened.	Replace the wheel studs. Check wheel nut torque daily. Torque wheel nuts at 100 to 110 lbs/ft. (135 to 149 nm)	3.6